

Canon

How to Use This Manual Printing This Manual



Basic Guide

Describes the summary of this product.



Advanced Guide

Describes the detailed function of this product.





Troubleshooting



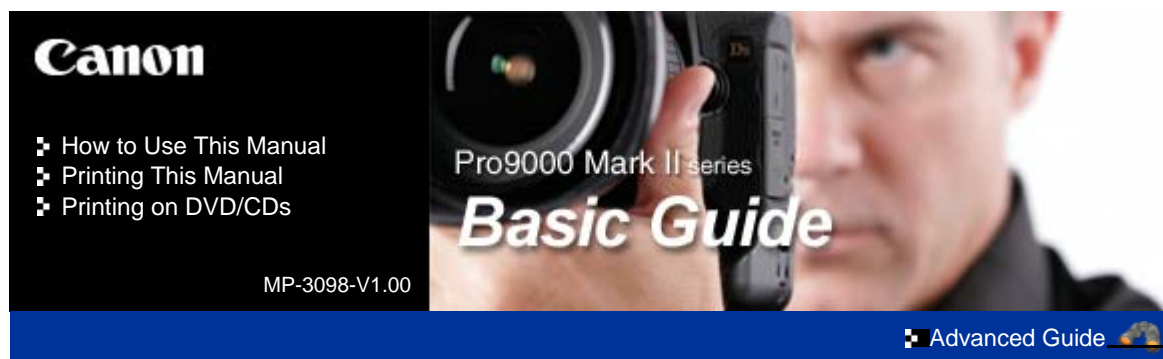

Digital Photo Printing Guide





Contents

-  Safety Precautions
-  **Overview of the Printer**
 - Main Components

-  **Printing Photos / Documents**
 - Printing Photos (Easy-PhotoPrint EX)
 - Printing Documents (Windows)
 - Printing Documents (Macintosh)

-  **Other Usages**
 - Printing Photos from a PictBridge Compliant Device
 - Solution Menu and My Printer

-  **Loading Paper**
 - Loading Paper

-  **Routine Maintenance**
 - Replacing an Ink Tank
 - When Printing Becomes Faint or Colors Are Incorrect
 - Cleaning the Paper Feed Rollers
 - Opening the Maintenance Screens

-  **Appendix**
 - Legal Limitations on Use of Your Product and Use of Images
 - Tips on How to Use Your Printer

⚠ Safety Precautions

Please read the safety warnings and cautions provided in this manual to ensure that you use the printer safely. Do not attempt to use the printer in any way not described in this manual. It causes unexpected accident, fire, or electric shock.

📖 Note

- The power supply is AC100-240V 50/60Hz via AC power supply unit K30309.

⚠ Warning



- The following are instructions that, if ignored, could result in death or serious personal injury caused by incorrect operation of the equipment. These must be observed for safe operation.

<p>Choosing a location</p>	<p>Do not place the printer close to flammable solvents such as alcohol or thinners.</p>
<p>Power supply</p>	<p>Never attempt to plug in or unplug the printer from the power supply when your hands are wet.</p> <p>Always push the plug all the way into the power outlet.</p> <div data-bbox="359 902 632 1099"> </div> <p>Never damage, modify, stretch or excessively bend or twist the power cord. Do not place heavy objects on the power cord.</p> <div data-bbox="359 1126 632 1323"> </div> <p>Never plug the printer into a power socket that is shared with other equipment (extension lead/cord, 2- or 3-way adapter, etc.).</p> <p>Never use the printer if the power cord is bundled or knotted.</p> <p>If you detect smoke, unusual smells or strange noises around the printer, immediately unplug the printer at the power supply and call for service.</p> <div data-bbox="359 1496 632 1693"> </div> <p>Periodically, unplug the printer and use a dry cloth to wipe off any dust or dirt collected on the plug and the power outlet. If the printer is placed at a location exposed to a lot of dust, smoke, or high humidity, the dust collected on the plug absorbs moisture and may cause insulation failure and fire.</p> <p>If you hear thunder, disconnect the power supply of the printer and refrain from using it. Leaving the printer plugged in may cause fire, electric shock, or damage to the printer, depending on the thunder storm.</p> <p>Use the power cable included with the printer.</p>
<p>Cleaning the printer</p>	<div data-bbox="359 1960 632 2141"> </div> <p>Use a damp cloth to clean the printer. Never use flammable solvents such as alcohol, benzene or thinners.</p> <p>If flammable solvents come in contact with electrical components inside the printer, it could cause a fire or electric shock.</p>

	<p>Always unplug the printer from the power outlet before cleaning the printer. If you accidentally switch the printer on while cleaning it, you could injure yourself or damage the printer.</p>
Maintaining the printer	<p>Do not attempt to disassemble or modify the printer. There are no user serviceable parts inside the printer. The printer contains high-voltage components. Never attempt any maintenance procedure not described in this guide.</p> <p>Do not connect other than recommended devices to the Direct Print Port or cable connector on the printer. It could cause a fire or electric shock.</p>
Working around the printer	<p>Do not use highly flammable sprays near the printer. This could cause a fire or electric shock if the spray comes into contact with electrical components inside the printer.</p>

⚠ Caution

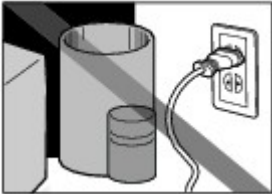
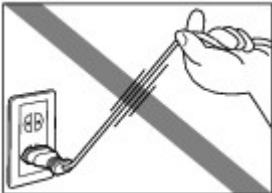
- The following are instructions that, if ignored, could result in personal injury or material damage caused by incorrect operation of the equipment. These must be observed for safe operation.

Choosing a location	<p>Do not install the printer in a location that is unstable or subject to excessive vibration.</p>
	<p>Do not install the printer in locations that are very humid or dusty, in direct sunlight, outdoors, or close to a heating source. To avoid the risk of fire or electric shocks, install the printer in a location with an ambient temperature range of 5°C to 35°C (41°F to 95°F) and humidity of 10% to 90% (condensation free).</p>
	<p>Do not place the printer on a thick rug or carpet.</p>
	<p>Do not place the printer with its back attached to the wall.</p>
Power supply	 <p>Ensure that the area around the power outlet is kept clear at all times so you can easily unplug the power cord if necessary.</p>
	 <p>Never remove the plug by pulling on the cord.</p>
	 <p>Do not use an extension lead/cord.</p>
Working around the printer	<p>Never put your hands or fingers in the printer while it is printing.</p>
	<p>When moving the printer, carry the printer at both ends.</p>
	<p>Do not place any object on the printer.</p>
	<p>Do not place metal objects (paper clips, staples, etc.) or containers of flammable solvents (alcohol, thinners, etc.) on top of the printer.</p>
	<p>If any foreign object (metal or liquid) fall into the printer, unplug the power cord and call for service.</p>

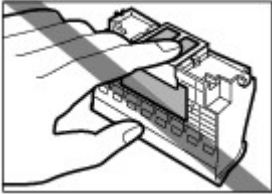
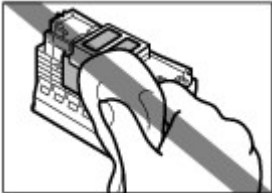
	<p>Do not transport or use the printer on a slant, vertically or upside-down, as the ink may leak and damage the printer.</p>
<p>Print Heads and ink tanks</p>	<p>Keep ink tanks out of the reach of children. In case ink is accidentally licked or swallowed, rinse out mouth or give one or two glasses of water to drink. If irritation or discomfort occurs, obtain medical advice immediately.</p>
	<p>In case ink gets in contact with eyes, rinse with water immediately. In case ink gets in contact with skin, wash with soap and water immediately. If irritation to eyes or skin persists, obtain medical advice immediately.</p>
	<p>Do not shake Print Heads or ink tanks. Ink may leak out and stain clothing or the surrounding area.</p>
	 <p>Never touch the electrical contacts on a Print Head after printing. The metal parts may be very hot and could cause burns.</p>
	<p>Do not throw ink tanks into fire.</p>
	<p>Do not attempt to disassemble or modify the Print Head and ink tanks.</p>
	<p>Do not handle the Print Head and ink tanks roughly such as applying them excessive pressure or dropping them.</p>
	 <p>Do not rinse or wipe the Print Head and ink tanks.</p>
<p>Once you have installed the Print Head and ink tanks, do not remove them unnecessarily.</p>	

- Note when you place the printer near other electrical appliances such as fluorescent lamps**
 Place the printer at least 5.91 inches / 15 cm away from other electrical appliances such as fluorescent lamps. If the printer is placed closer to those, it may not be able to work properly due to fluorescent noises.
- When you disconnect the power plug**
 When you disconnect the power plug, always press the **Power** button and be sure that the **Power** lamp (in green) has gone out. If you disconnect the power plug from the power outlet when the **Power** lamp lights or flashes, the Print Head cannot be protected and you may not be able to print later.

Overview of the Printer

This section shows the component names of the printer and describes their functions.

Main Components

[Front View](#)
[Rear View](#)
[Inside View](#)



[↑ Page top](#)

- Do not touch the metal casing.

(8) Front Tray

Printed paper ejects here. Open it before printing.

Load paper in the Front Tray to print on large size paper, such as 14" x 17" / 36 x 43 cm paper, or on thick paper.

See [Loading Paper in the Front Tray](#) and [Media Types You Can Use](#).

(9) Front Tray Extension

Pull out to support paper. Pull it out before printing.

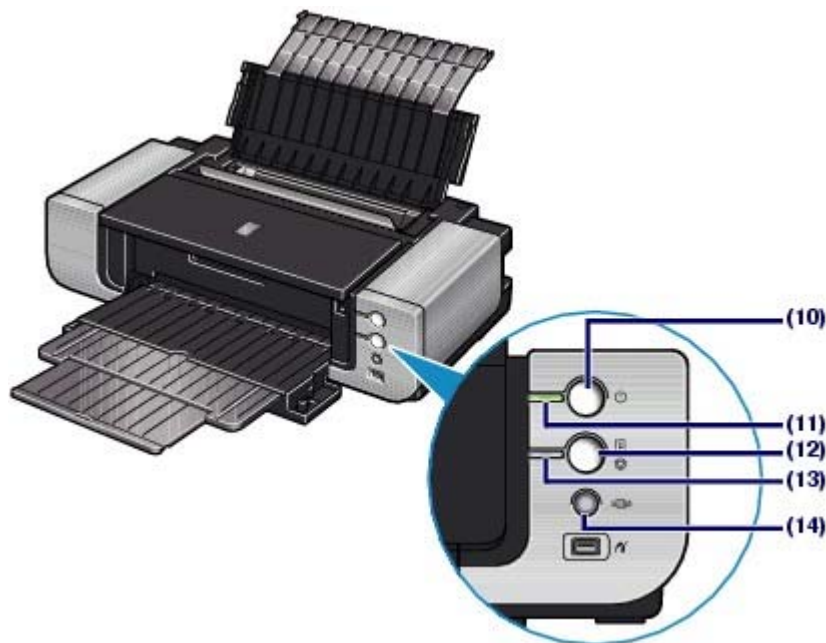

(10) Power button

Press to turn the power on or off.

Important

Disconnecting the power plug

- When disconnecting the power plug after turning off the power, be sure to confirm that the **Power** lamp is not lit. If the power plug is disconnected from the wall outlet while the **Power** lamp is lit or flashing, the printer may become unable to print properly since the Print Head is not protected.

Note

Auto power on/off feature

- You can set the printer to turn on or off automatically.
 - Auto Power On: Automatically turns on the printer when print data is sent from the computer.
 - Auto Power Off: Automatically turns off the printer when no print data is sent for a certain interval.

Specify this setting in the Maintenance sheet of the printer driver setup window (Windows) or in the Canon IJ Printer Utility (Macintosh).

For details on the settings, refer to the on-screen manual: [Advanced Guide](#).

(11) Power lamp

Lights green after flashing when the power is turned on.

(12) RESUME/CANCEL button

Press to cancel a print job in progress. You can press this button after resolving a printer error to dismiss an error message and resume printing.

(13) Alarm lamp

Lights or flashes orange when an error, such as paper-out or ink-out, occurs.

Note

Power and Alarm lamps

- You can check the status of the printer by the **Power** and **Alarm** lamps.

- **Power** lamp is off: The power is off.
- **Power** lamp lights green: The printer is ready to print.
- **Power** lamp flashes green: The printer is getting ready to print, or printing is in progress.
- **Alarm** lamp flashes orange: An error has occurred and the printer is not ready to print.
For details, refer to "[Troubleshooting](#)" in the on-screen manual: *Advanced Guide*.
- **Power** lamp flashes green once and **Alarm** lamp flashes orange once alternately: An error that requires contacting the service center may have occurred. For details, refer to "[Troubleshooting](#)" in the on-screen manual: *Advanced Guide*.

(14) Front Feed button

Press it when feeding paper from the Front Tray. You can check the printer status by the indication of the **Front Feed** button when feeding paper from the Front Tray.

See [Loading Paper in the Front Tray](#) .

Note

Indication of the Front Feed button

- **Front Feed** button flashes quickly (two flashes at a time): The printer is ready to load paper in the Front Tray. Load paper in the Front Tray properly.
- **Front Feed** button flashes slowly (one long flash at a time): The printer is ready to feed paper from the Front Tray. Start printing.
- **Front Feed** button is not lit: The printer is set to feed paper from the Rear Tray.
- **Front Feed** button lights: The printer is set to feed paper from the Front Tray.

■ Rear View

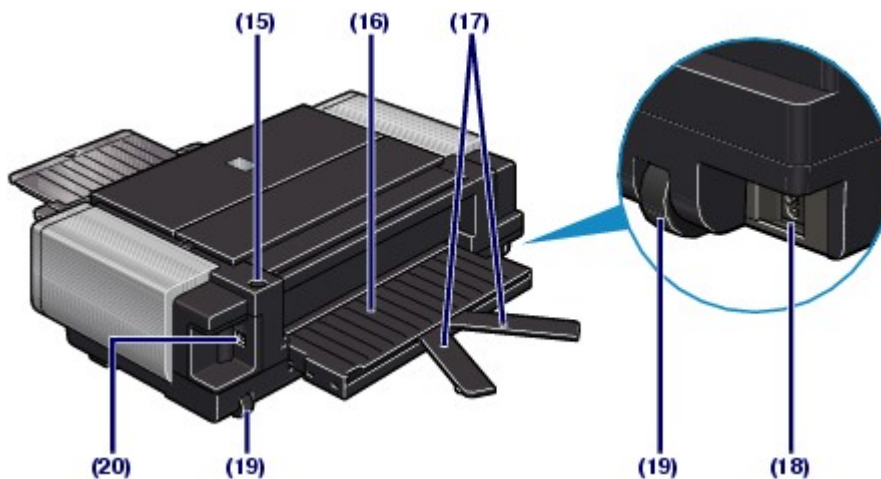

(15) Front Feed Support button

Press to open the Front Feed Support.

(16) Front Feed Support

Open it when feeding paper from the Front Tray.

(17) V-shaped Support

Open to support paper when feeding paper larger than A4 size from the Front Tray.

(18) Power Cord Connector

Plug in the supplied power cord.

(19) Wheels

Used to move the printer. Lift up the front of the printer to move it back and forth.

(20) USB Port

Plug in the USB cable to connect the printer with a computer.

Important

- Do not touch the metal casing.
- Do not plug in or unplug the USB cable while printing.

■ Inside View

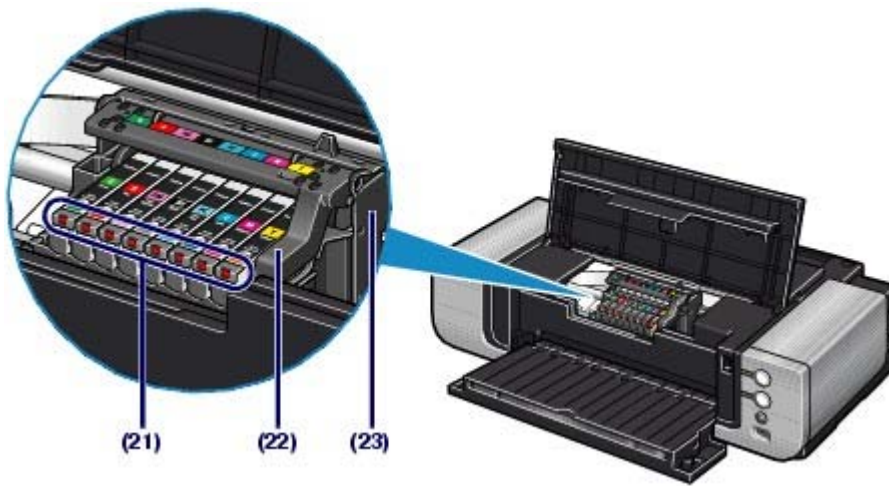
**(21) Ink lamp**

Lights or flashes red to indicate the ink tank status.

See [Checking the Ink Status](#).

(22) Print Head Lock Lever

Locks the Print Head into place.

⚠ Important

- Do not raise this lever after installing the Print Head.

(23) Print Head Holder

Install the Print Head.

📖 Note

- For details on installing the Print Head and ink tanks, refer to the printed manual: *Getting Started*.



[↑ Page top](#)

Printing Photos / Documents

This section describes how to print documents or photos.

You can easily print photos taken with your digital camera by using Easy-PhotoPrint EX supplied with your printer.

This section also introduces the supplied plug-in application, Easy-PhotoPrint Pro, that provides photo editing and printing with optimal reproduction of image color and quality.

Printing Photos (Easy-PhotoPrint EX)

[Using Various Functions of Easy-PhotoPrint EX](#)

[Using Various Functions of Easy-PhotoPrint Pro](#)

Printing Documents (Windows)

Printing Documents (Macintosh)

[For Mac OS X v.10.5.x](#)

[For Mac OS X v.10.4.x or Mac OS X v.10.3.9](#)



Printing Photos (Easy-PhotoPrint EX)

Print image data saved on your computer by using Easy-PhotoPrint EX supplied with your printer. This section describes the procedure, using the settings to print borderless photos on 4" x 6" / 10 x 15 cm photo paper as an example.

For details on Easy-PhotoPrint EX, refer to the on-screen manual: [Advanced Guide](#).

Note

- The screens used in this section are for printing with Windows. The operations are also the same for printing with Macintosh.
- Install Easy-PhotoPrint EX from the *Setup CD-ROM* when it has not been installed or has been uninstalled. To install Easy-PhotoPrint EX, select Easy-PhotoPrint EX in Custom Install.

1. Prepare for printing.

(1) Make sure that the printer is turned on.

See [Front View](#).

(2) Load paper.

See [Loading Paper in the Rear Tray](#).

Here we load 4" x 6" / 10 x 15 cm photo paper in the Rear Tray.

(3) Gently press the upper center of the Front Tray to open it.

(4) Pull out the Front Tray Extension.

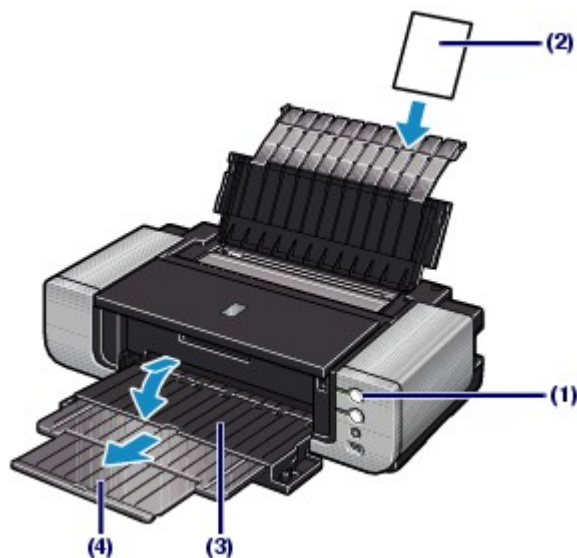

Note

- To load paper in the Front Tray, see [Loading Paper in the Front Tray](#).

2. Start Easy-PhotoPrint EX, and select Photo Print.

(1) Start Easy-PhotoPrint EX.



Double-click  (Easy-PhotoPrint EX) on the desktop.



Click Here: [Easy-PhotoPrint EX](#)





Select the Go menu, Applications, Canon Utilities, Easy-PhotoPrint EX, then double-click Easy-



PhotoPrint EX.

Note

Windows

- To start Easy-PhotoPrint EX from Solution Menu, double-click  (Solution Menu) on the desktop and click  (Print photos or albums, etc.). See [To Start Solution Menu](#).
- To start Easy-PhotoPrint EX from the Start menu, select All Programs (Programs in Windows 2000), Canon Utilities, Easy-PhotoPrint EX, then Easy-PhotoPrint EX.

Macintosh

- To start Easy-PhotoPrint EX from Solution Menu, click  (Solution Menu) in the Dock and click  (Print photos or albums, etc.). See [To Start Solution Menu](#).

(2) Click Photo Print.

Note

- You can select Album, Calendar, Stickers, etc., besides Photo Print. See [Using Various Functions of Easy-PhotoPrint EX](#).

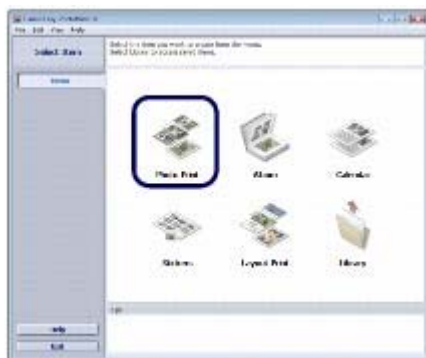



3. Select a photo to print.

(1) Select the folder in which images are saved.

(2) Click the image to print.

The number of copies appears as "1", and the image you selected appears in the selected image area (A). You can select two or more images at the same time.

Note

- To print two or more copies, click  (Up arrow) to change the number of copies.
- To cancel the selection, click the image to cancel in the selected image area and click  (Delete Imported Image). You can also use  (Down arrow) to change the number of copies to zero.
- You can also correct or enhance the selected image. See [Using Various Functions of Easy-PhotoPrint EX](#).

(3) Click Select Paper.



4. Select the loaded paper.

(1) Make sure that your printer's name is selected in Printer.

(2) Select Rear Tray in Paper Source.

Note

- To feed paper from the Front Tray, select Front Tray in Paper Source.

(3) Select the size and type of the loaded paper in Paper Size and Media Type.

Here we select 4"x6" 10x15cm in Paper Size and the type of the loaded photo paper in Media Type.

Note

- If you select the wrong media type, the printer may not print with the proper print quality.

(4) Click Layout/Print.

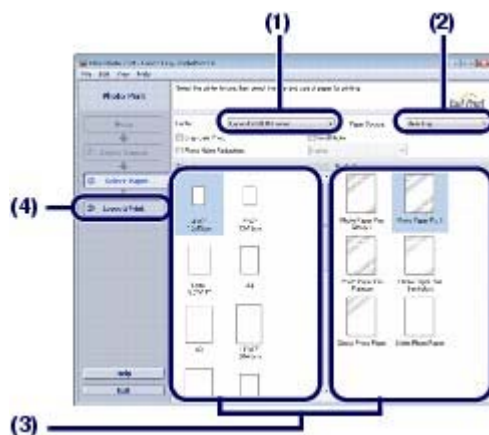

Note

- To print photos in grayscale, select Grayscale Photo.

5. Select a layout and start printing.

(1) Select the layout of the photo.

Here we select Borderless [full].

The preview appears in the selected layout for confirmation of the required print result.

Note

- You can change the direction of photo or crop a part of photo (trimming) to print.
For details on the operation, refer to the on-screen manual: [Advanced Guide](#).

(2) Click Print.

Note

Windows

- To cancel a print job in progress, press the **RESUME/CANCEL** button on the printer or click Cancel Printing on the printer status monitor.
To display the printer status monitor, click Canon XXX (where "XXX" is your printer's name) on the taskbar.

Macintosh

- Click the printer icon in the Dock to display the list of print jobs in progress.
 - To cancel a print job in progress, select the desired job in the Name list and click Delete.
To temporarily stop a job in progress, click Hold. To temporarily stop all the jobs in the list, click Pause Printer (or Stop Jobs).
-



Note

- To print photos in grayscale, we recommend selecting Bordered [Margin 45]. When you select the paper smaller than 8" x 10" / 20 x 25 cm in Paper Size, Bordered [Margin 45] is not available.
-



Basic Guide[Advanced Guide](#) [Troubleshooting](#)

[Contents](#) > [Printing Photos / Documents](#) > [Printing Photos \(Easy-PhotoPrint EX\)](#) > Using Various Functions of Easy-PhotoPrint EX

■ Using Various Functions of Easy-PhotoPrint EX

This section describes a few of the useful functions of Easy-PhotoPrint EX.
For details, refer to the on-screen manual: [Advanced Guide](#).

● Creating Your Own Prints

You can create an album or calendar using your photos.



Album



Calendar



Stickers



Layout Print

● Correcting Images

You can use Red-Eye Correction, Face Sharpener, Digital Face Smoothing, Brightness, Contrast, etc. to adjust, correct, or enhance images automatically or manually.



Brightness



[↑ Page top](#)

Basic Guide

■ [Advanced Guide](#) ■ [Troubleshooting](#)

[Contents](#) > [Printing Photos / Documents](#) > [Printing Photos \(Easy-PhotoPrint EX\)](#) > Using Various Functions of Easy-PhotoPrint Pro

■ Using Various Functions of Easy-PhotoPrint Pro

Easy-PhotoPrint Pro is a plug-in application started from Adobe Photoshop or Digital Photo Professional for Canon brand Single Lens Reflex camera.

Easy-PhotoPrint Pro allows easy performance of various photo prints, such as borderless print, index print, grayscale print, or print using Adobe RGB.

For details, refer to the on-screen manual: [Advanced Guide](#).

Note

- Easy-PhotoPrint Pro is only compatible with Adobe Photoshop CS/Photoshop CS2/Photoshop CS3/Photoshop Elements 6, or Digital Photo Professional Ver.2.1 or later.
For updated compatibility, visit our website.



Color management function compatible with Adobe RGB



Adobe RGB



sRGB

Print in various layouts



Bordered [full] print



Index print

Color correction while viewing a sample pattern

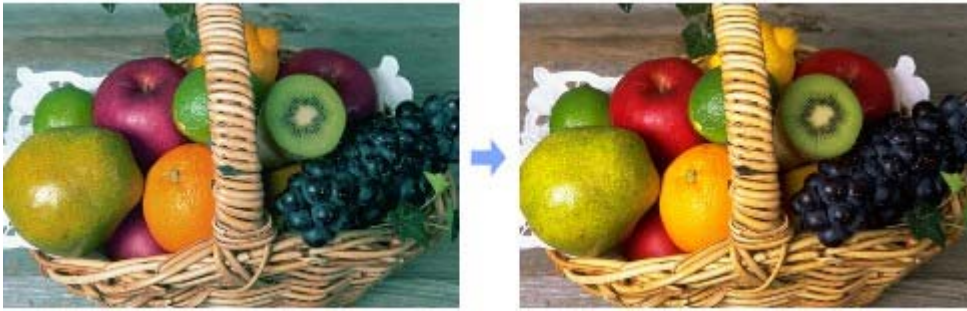

Produce retro flavor by grayscale photos



Cool Tone



Black/White (Default)



Warm Tone

Note

Ambient light correction function

- When you use Easy-PhotoPrint Pro in Windows Vista, you can print using the ambient light correction function. Ambient light correction is a function that reduces the differences in the way images appear depending on the place where they are viewed, displayed or exhibited. You can print in color tones suitable for each lighting condition.



[↑ Page top](#)

Printing Documents (Windows)

This section describes the procedure, using the settings to print a document of A4 size on plain paper as an example.

For details, refer to the on-screen manual: [Advanced Guide](#).

Note

- Operations may vary depending on your software application. For details on the operation, refer to the instruction manual of your application.
- The screens used in this section are for printing with Windows Vista operating system Ultimate Edition (hereafter referred to as "Windows Vista").
- When printing in grayscale, depending on an image, the printing troubles may occur on the top and/or bottom edges of the paper such as uneven coloration or white streaks. In this case, we recommend printing on paper with top and bottom margins of 1.77 inches / 45 mm or more according to the direction of printing, using Easy-PhotoPrint Pro provided on the *Setup CD-ROM* or your page layout software application.
When using a page layout software application or the like, prepare paper whose longer side is at least 3.54 inches / 90 mm longer than the length of the image, then print it with top and bottom margins of 1.77 inches / 45 mm or more according to the direction of printing.
For details on grayscale printing, refer to the on-screen manual: [Digital Photo Printing Guide](#).

1. Make sure that the printer is turned on.

See [Front View](#).

2. Load paper.

See [Loading Paper in the Rear Tray](#).

Here we load A4 plain paper in the Rear Tray.

Note

- To load paper in the Front Tray, see [Loading Paper in the Front Tray](#).

3. Open the Front Tray gently, and pull out the Front Tray Extension.

Gently press the upper center of the Front Tray to open it.

4. Create (or open) a document to print using an appropriate software application.

5. Open the printer driver setup window.

(1) Select Print on the File menu or the command bar in your software application.

The Print dialog box will appear.

(2) Make sure that your printer's name is selected.

Note

- If another printer's name is selected, click and select your printer's name.

(3) Click Preferences (or Properties).

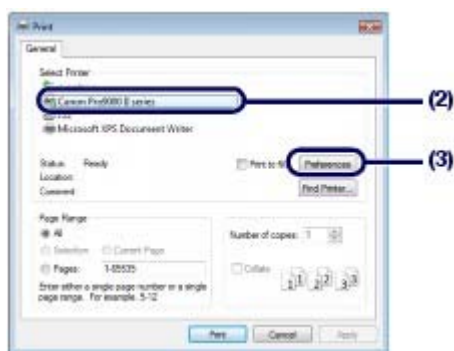

6. Specify the required print settings.

(1) Select Business Document in Commonly Used Settings.

Note

- When the print object such as Business Document or Photo Printing is selected in Commonly Used Settings, the items in Additional Features will be selected automatically. The settings suitable for the print object such as media type or print quality will also appear.
- When you specify two or more copies in Copies, the Collate check box will be selected.

(2) Make sure of the displayed settings.

Here we make sure that Plain Paper in Media Type, Standard in Print Quality, A4 in Printer Paper Size, and Rear Tray in Paper Source are selected.

Note

- The settings can be changed. However, after changing Printer Paper Size, confirm that the setting for Page Size in the Page Setup sheet matches the setting set in the software application. For details, refer to the on-screen manual: [Advanced Guide](#).
- To feed paper from the Front Tray, select Front Tray in Paper Source.

(3) Click OK.

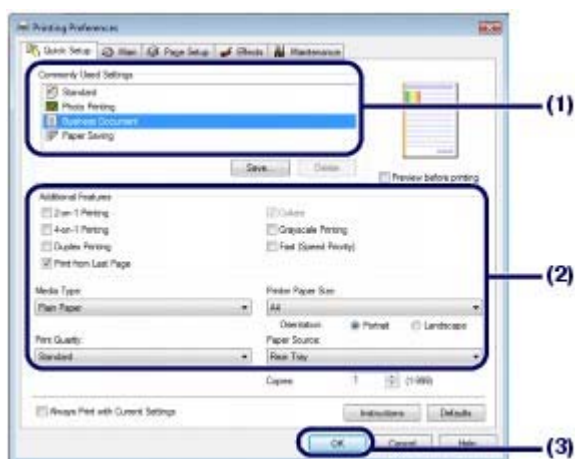

Note

- For details on the printer driver functions, click Help or Instructions to view the online help or the on-screen manual: [Advanced Guide](#). The Instructions button appears on the Quick Setup, Main, and Maintenance sheets if the on-screen manual is installed on your computer.
- You can name the changed settings and add to Commonly Used Settings. For details, refer to the on-screen manual: [Advanced Guide](#).
- To display the current settings next time when you open the printer driver setup window, select the Always Print with Current Settings check box. Some software applications may not have this function.
- To display the preview to confirm the print result, select the Preview before printing check box. Some software applications may not have a preview function.
- You can specify detailed print settings on the Main sheet or Page Setup sheet. For details, refer to the on-screen manual: [Advanced Guide](#).

7. Start printing.

Click Print (or OK) to start printing.



Note

- To cancel a print job in progress, press the **RESUME/CANCEL** button on the printer or click Cancel Printing on the printer status monitor.
To display the printer status monitor, click Canon XXX (where "XXX" is your printer's name) on the taskbar.
- If printed ruled lines are misaligned or print results are unsatisfactory, adjust the print head position.
See [Aligning the Print Head](#).



[↑ Page top](#)

Printing Documents (Macintosh)

This section describes the procedure, using the settings to print a document of A4 size on plain paper as an example.

For details, refer to the on-screen manual: [Advanced Guide](#).

Note

- Operations may vary depending on your software application. For details on the operation, refer to the instruction manual of your application.
- When printing in grayscale, depending on an image, the printing troubles may occur on the top and/or bottom edges of the paper such as uneven coloration or white streaks. In this case, we recommend printing on paper with top and bottom margins of 1.77 inches / 45 mm or more according to the direction of printing, using Easy-PhotoPrint Pro provided on the *Setup CD-ROM* or your page layout software application.

When using a page layout software application or the like, prepare paper whose longer side is at least 3.54 inches / 90 mm longer than the length of the image, then print it with top and bottom margins of 1.77 inches / 45 mm or more according to the direction of printing.

For details on grayscale printing, refer to the on-screen manual: [Digital Photo Printing Guide](#).

■ For Mac OS X v.10.5.x

1. Make sure that the printer is turned on.

See [Front View](#).

2. Load paper.

See [Loading Paper in the Rear Tray](#).

Here we load A4 plain paper in the Rear Tray.

Note

- To load paper in the Front Tray, see [Loading Paper in the Front Tray](#).

3. Open the Front Tray gently, and pull out the Front Tray Extension.

Gently press the upper center of the Front Tray to open it.

4. Create (or open) a document to print using an appropriate software application.

5. Open the Print dialog box.

Select Print on the File menu in your software application.

The Print dialog box will appear.

Note

- If the dialog box below appears, click  (Down arrow).



6. Specify the required print settings.

- (1) Make sure that your printer's name is selected in Printer.
- (2) Select the page size of the loaded paper in Paper Size.
Here we select A4.
- (3) Select Quality & Media in the pop-up menu.

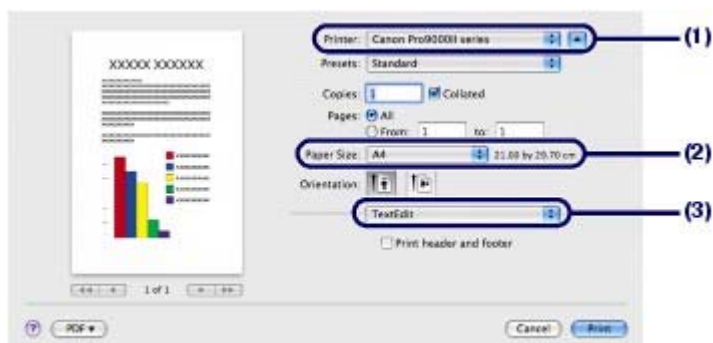

- (4) Select the media type of the loaded paper in Media Type.
Here we select Plain Paper.

Note

- If you select the wrong media type, the printer may not print with the proper print quality.

- (5) Select Rear Tray in Paper Source.

Note

- To feed paper from the Front Tray, select Front Tray in Paper Source.

- (6) Select the print quality in Print Quality.
Here we select Standard.

Note

- For details on the print quality, refer to the on-screen manual: [Advanced Guide](#).

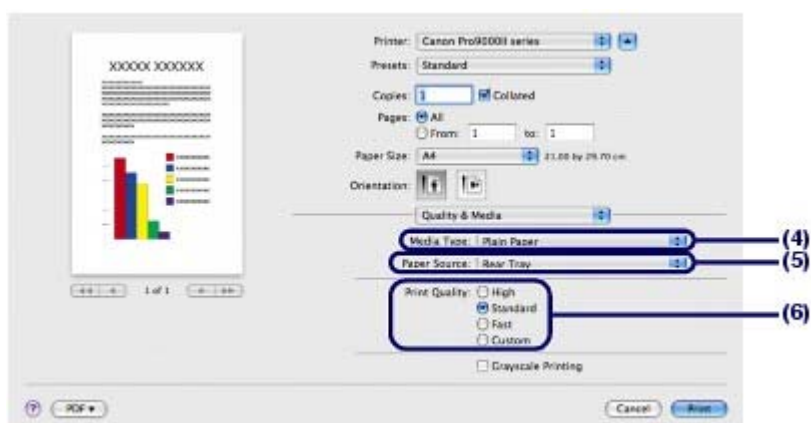

Note

- For details on the printer driver functions, click (Question) on the Quality & Media, Color Options, Borderless Printing, or Margin screen to view the on-screen manual: *Advanced Guide*. If the on-screen manual is not installed, it does not appear even if (Question) is clicked.
- The preview appears on the left of the dialog box to confirm the print result. Some software applications may not have a preview function.

7. Start printing.

Click Print to start printing.

Note

- Click the printer icon in the Dock to display the list of print jobs in progress.
- To cancel a print job in progress, select the desired job in the Name list and click Delete.
To temporarily stop a job in progress, click Hold. To temporarily stop all the jobs in the list, click Pause Printer.
- If printed ruled lines are misaligned or print results are unsatisfactory, adjust the print head position.
See [Aligning the Print Head](#).

■ For Mac OS X v.10.4.x or Mac OS X v.10.3.9

Note

- The screens used in this section are for printing with Mac OS X v.10.4.x.

1. Make sure that the printer is turned on.

See [Front View](#).

2. Load paper.

See [Loading Paper in the Rear Tray](#).

Here we load A4 plain paper in the Rear Tray.

Note

- To load paper in the Front Tray, see [Loading Paper in the Front Tray](#).

3. Open the Front Tray gently, and pull out the Front Tray Extension.

Gently press the upper center of the Front Tray to open it.

4. Create (or open) a document to print using an appropriate software application.

5. Specify the page size.

(1) Select Page Setup on the File menu in your software application.

The Page Setup dialog box will appear.

(2) Make sure that your printer's name is selected in Format for.

(3) Select the page size of the loaded paper in Paper Size.

Here we select A4.

(4) Click OK.



6. Specify the required print settings.

(1) Select Print on the File menu in your software application.

The Print dialog box will appear.

(2) Make sure that your printer's name is selected in Printer.

(3) Select Quality & Media in the pop-up menu.

(4) Select the media type of the loaded paper in Media Type.

Here we select Plain Paper.

Note

- If you select the wrong media type, the printer may not print with the proper print quality.

(5) Select Rear Tray in Paper Source.

Note

- To feed paper from the Front Tray, select Front Tray in Paper Source.

(6) Select the print quality in Print Quality.



Here we select Standard.

Note

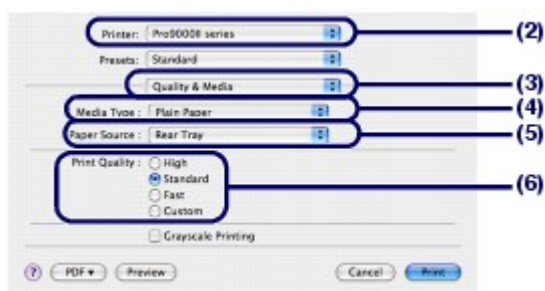
- For details on the print quality, refer to the on-screen manual: [Advanced Guide](#).



Note

- For details on the printer driver functions, click  (Question) on the Quality & Media, Color Options, Special Effects, Borderless Printing, or Margin screen to view the on-screen manual: *Advanced Guide*. If the on-screen manual is not installed, it does not appear even if  (Question) is clicked.
- To display the preview to confirm the print result, click Preview. Some software applications may not have a preview function.

7. Start printing.

Click Print to start printing.

Note

- Click the printer icon in the Dock to display the list of print jobs in progress.
- To cancel a print job in progress, select the desired job in the Name list and click Delete. To temporarily stop a job in progress, click Hold. To temporarily stop all the jobs in the list, click Stop Jobs.
- If printed ruled lines are misaligned or print results are unsatisfactory, adjust the print head position. See [Aligning the Print Head](#).



[↑ Page top](#)

Other Usages

This section describes the function to print photos from your PictBridge compliant device such as a digital camera connecting with a USB cable.

This section also introduces other useful functions; Solution Menu and My Printer.

Printing Photos from a PictBridge Compliant Device

Solution Menu and My Printer



[↑ Page top](#)

Printing Photos from a PictBridge Compliant Device

Connecting the PictBridge compliant device to the printer with a USB cable that is recommended by the device's manufacturer, you can print saved images directly.

For the basic features of printing from a PictBridge compliant digital camera, such as compatible media types, available layouts, and image correction function, refer to the on-screen manual: [Advanced Guide](#).

For details on the print settings on the PictBridge compliant device, refer to the instruction manual supplied with the device.



Connectable devices:

Any PictBridge compliant device can be connected to the printer regardless of the manufacturer or model as long as it is compliant with the PictBridge Standard.

Note

- PictBridge is the standard to print your photos directly without using a computer, connecting a device such as a digital still camera, digital camcorder, or camera-equipped mobile phone.



(PictBridge) A device with this mark is PictBridge compliant.

- With some Canon brand Single Lens Reflex cameras that are PictBridge compliant, you can select a desired color mode and make detailed color adjustments.

For details on the color mode, refer to the on-screen manual: [Digital Photo Printing Guide](#) or the instruction manual supplied with your Canon brand PictBridge compliant device.

Printable image data format:

This printer accepts images* taken with a camera compliant with the Design rule for Camera File system.

* Exif 2.2/2.21 compliant



Solution Menu and My Printer

Using Solution Menu or My Printer, you can easily get the information on the printer or change the print settings by only clicking buttons on a screen.

With Solution Menu, you can start the software applications supplied with the printer or display the operating instructions. It also provides you with the information on troubleshooting.

With My Printer, you can display the printer driver setup window. It also provides you with the information on how to take an action when you have trouble with the operation. My Printer is not available in Macintosh.

● To Start Solution Menu



Double-click  (Solution Menu) on the desktop.



Click Here: [Solution Menu](#)



Click  (Solution Menu) in the Dock.

* The screens below are for Windows Vista.



Click the button of a function to use.



After starting Solution Menu, click the button on the title bar to reduce the window size.



Note

- Install Solution Menu from the *Setup CD-ROM* when it has not been installed or has been uninstalled. To install Solution Menu, select Solution Menu in Custom Install.
- The buttons displayed on the screen may vary depending on the country or region of purchase.



- To start Solution Menu from the Start menu, select All Programs (Programs in Windows 2000), Canon Utilities, Solution Menu, then Solution Menu.



- To start Solution Menu from the menu bar, select the Go menu, Applications, Canon Utilities, Solution Menu, then double-click Solution Menu.

● To Start My Printer



Double-click  (My Printer) on the desktop.



Note

- You can also start My Printer from Solution Menu.
 - Install My Printer from the *Setup CD-ROM* when it has not been installed or has been uninstalled. To install My Printer, select My Printer in Custom Install.
 - To start My Printer from the Start menu, select All Programs (Programs in Windows 2000), Canon Utilities, My Printer, then My Printer.
-



[↑ Page top](#)

Loading Paper

This section describes types of paper you can load and how to load printing paper in the Rear Tray or Front Tray.

Loading Paper

[Paper Source to Load Paper](#)

[Notes on Loading Paper](#)

[Loading Paper in the Rear Tray](#)

[Loading Paper in the Front Tray](#)

[Media Types You Can Use](#)

[Media Types You Cannot Use](#)

[Handling Paper](#)



[↑ Page top](#)

Loading Paper

- ➔ [Paper Source to Load Paper](#)
- ➔ [Notes on Loading Paper](#)
- ➔ [Loading Paper in the Rear Tray](#)
- ➔ [Loading Paper in the Front Tray](#)
- ➔ [Media Types You Can Use](#)
- ➔ [Media Types You Cannot Use](#)
- ➔ [Handling Paper](#)

■ Paper Source to Load Paper

The printer has two paper sources to feed paper, Rear Tray and Front Tray.

Select either one of the paper sources, depending on the size or type of paper to load.

See [Media Types You Can Use](#).

● Loading Two or More Sheets of Paper in the Rear Tray

You can load various sizes of paper, from 4" x 6" / 10 x 15 cm to A3+ (13" x 19") paper, in the Rear Tray.

Two or more sheets of the same size and type of paper can be loaded at a time so that you can print continuously. (Some sizes or types of paper can be loaded only one sheet at a time.)

Select Rear Tray in Paper Source in the printer driver setting when printing from the Rear Tray.



● Loading One Sheet of Large Size Paper or Thick Paper in the Front Tray

You can load large size paper such as 14" x 17" / 36 x 43 cm paper, or thick paper such as art paper and board paper, in the Front Tray.

Select Front Tray in Paper Source in the printer driver setting when printing from the Front Tray.



■ Notes on Loading Paper

Important

- If you cut plain paper into small size such as 4" x 6" / 10 x 15 cm, 4" x 8" / 101.6 x 203.2 mm, or 5" x 7" / 13 x 18 cm to perform trial print, it can cause paper jams.

Note

- We recommend Canon genuine photo paper for printing photos.
For details on the Canon genuine paper, see [Media Types You Can Use](#).
 - You can use general copy paper.
For the page size and paper weight/thickness you can use for the printer, see [Media Types You Can Use](#).
-



[↑ Page top](#)

■ Loading Paper in the Rear Tray

Before loading paper, see [Notes on Loading Paper](#).

Note

- You can load A3+ (13" x 19"), A3, B4, A4, B5, A5, Letter, Legal, 11" x 17" / 279.4 x 431.8 mm (Tabloid), Wide (4" x 7.1"), 4" x 6" / 10 x 15 cm, 4" x 8" / 101.6 x 203.2 mm, 5" x 7" / 13 x 18 cm, 8" x 10" / 20 x 25 cm, and 10" x 12" / 25 x 30 cm sizes of paper, and envelopes in the Rear Tray.

● Loading Plain Paper / Photo Paper

1. Prepare paper.

Align the edges of paper. If paper is curled, flatten it.

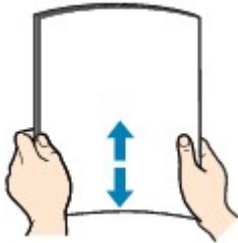

Note

- Align the edges of paper neatly before loading. Loading paper without aligning the edges may cause paper jams.
- If paper is curled, hold the curled corners and gently bend them in the opposite direction until the paper becomes completely flat.
For details on how to flatten curled paper, refer to "[Troubleshooting](#)" in the on-screen manual: *Advanced Guide*.

2. Load paper.

- (1) Open the Paper Support.
- (2) Gently press the upper center of the Front Tray to open it.
- (3) Pull out the Front Tray Extension.
- (4) Make sure that the **Front Feed** button is not lit.
If the **Front Feed** button is lit or flashing, set the Front Tray to its normal printing position.
See [Returning the Front Tray to Its Normal Printing Position](#).

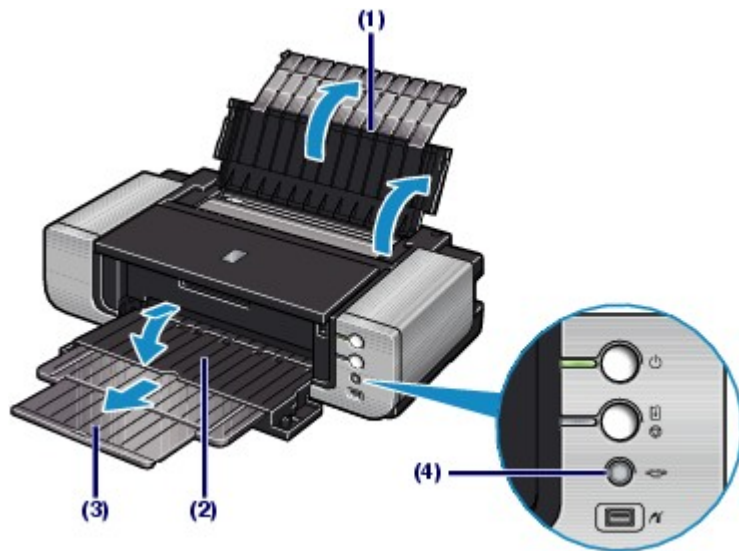

(5) Open the Feed Slot Cover.



(6) Load the paper in the Rear Tray WITH THE PRINT SIDE FACING YOU.
Align the paper stack with the right edge of the Rear Tray.

Important

- Always load paper in the portrait orientation (A). Loading paper in the landscape orientation (B) can cause paper jams.



(A)

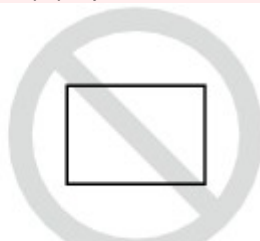

(B)

(7) Slide the Paper Guide to align it with the left side of the paper stack.
Do not slide the Paper Guide too hard. The paper may not be fed properly.

Note

- Do not load sheets of paper higher than the Load Limit Mark (C).

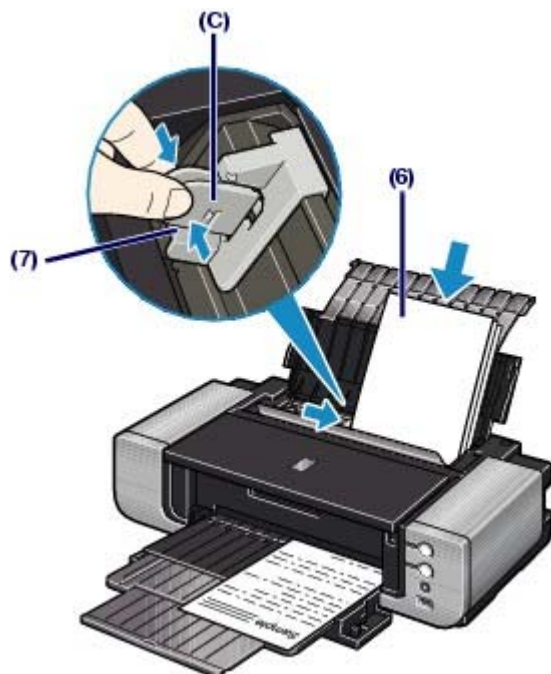

(8) Close the Feed Slot Cover.

Note

After loading paper

- Select the size and type of the loaded paper in Printer Paper Size (or Paper Size) and Media Type in the printer driver.
See [Printing Documents \(Windows\)](#) or [Printing Documents \(Macintosh\)](#).

● Loading Envelopes

You can print on European DL and US Comm. Env. #10-sized envelopes.

The address is automatically rotated and printed according to the envelope's direction by specifying with the printer driver properly.

Important

- You cannot use the following envelopes.
 - Envelopes with an embossed or treated surface
 - Envelopes with a double flap (or sticker flaps)
 - Envelopes whose gummed flaps are already moistened and adhesive

Note

- You cannot load envelopes in the Front Tray. Load them in the Rear Tray.

1. Prepare envelopes.

- Press down on all four corners and edges of the envelopes to flatten them.

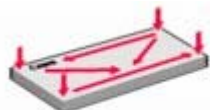

- If the envelopes are curled, hold the opposite corners and gently twist them in the opposite direction.



- If the corner of the envelope flap is folded, flatten it.

- Use a pen to press the leading edge in the inserting direction flat and sharpen the crease.

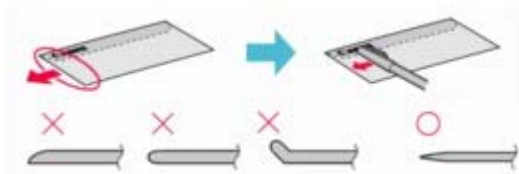

The figures above show a side view of the leading edge of the envelope.

Important

- The envelopes may jam in the printer if they are not flat or the edges are not aligned. Make sure that no curl or puff exceeds 0.1 inches / 3 mm.

2. Load envelopes.

- (1) Open the Paper Support.
- (2) Gently press the upper center of the Front Tray to open it.
- (3) Pull out the Front Tray Extension.
- (4) Make sure that the **Front Feed** button is not lit.
If the **Front Feed** button is lit or flashing, set the Front Tray to its normal printing position.
See [Returning the Front Tray to Its Normal Printing Position](#).

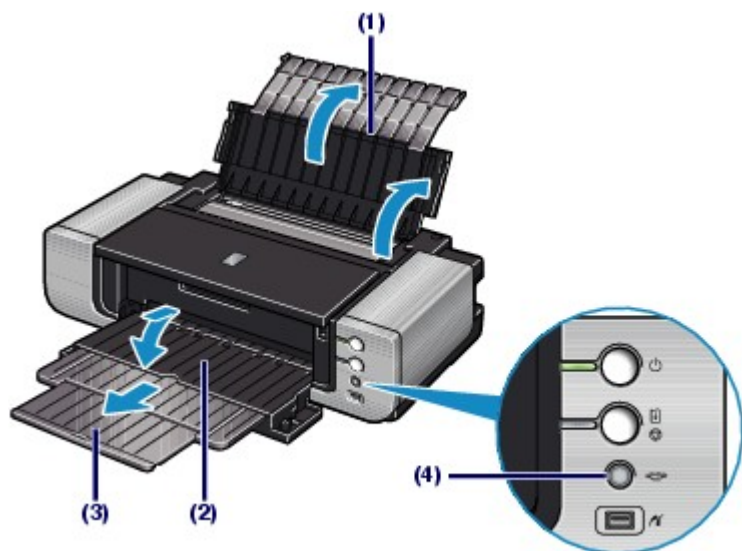

- (5) Open the Feed Slot Cover.



- (6) Load the envelopes in the Rear Tray **WITH THE ADDRESS SIDE FACING YOU**.

Align the envelopes with the right edge of the Rear Tray. The folded flap of the envelope will be faced down on the left side.

Up to 10 envelopes can be loaded at once.

- (7) Slide the Paper Guide to align it with the left side of the envelopes.

Do not slide the Paper Guide too hard. The envelopes may not be fed properly.

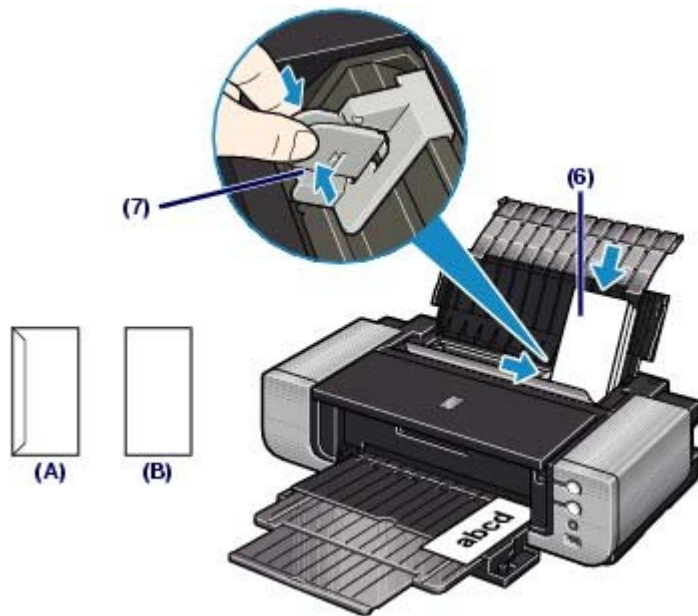

(A) Rear side

(B) Address side

(8) Close the Feed Slot Cover.

3. Specify the settings in the printer driver.



- (1)** Select Business Document in Commonly Used Settings on the Quick Setup sheet.
- (2)** Select Envelope in Media Type.
- (3)** Select DL Env. or Comm. Env. #10 in Printer Paper Size.
- (4)** Select Landscape in Orientation.



Note

- If the print result is upside down, select Rotate 180 degrees on the Page Setup sheet in the printer driver setup window.



- (1)** Select Envelope in Media Type.
- (2)** Select DL Envelope or #10 Envelope in Paper Size.
- (3)** Select the landscape orientation in Orientation.



Important

- If you do not specify Printer Paper Size (or Paper Size) or Orientation properly, the address will be printed upside down or will be turned to 90 degrees.



Note

- For details on the printer driver settings, see [Printing Documents \(Windows\)](#) or [Printing Documents \(Macintosh\)](#).
- When printing starts, the printer may not detect the envelope correctly depending on the type of envelope. If the **Alarm** lamp flashes orange eleven times, set the printer driver not to detect the width of the paper. Refer to "Error Regarding the Width of Paper Is Displayed" in "[Troubleshooting](#)" of the on-screen manual: *Advanced Guide*.



[↑ Page top](#)

■ Loading Paper in the Front Tray

Before loading paper, see [Notes on Loading Paper](#).

⚠ Important

- When loading paper in the Front Tray, the paper sticks out from the back of the printer. Keep a space of 15.7 inches / 40 cm for this purpose behind the printer.
- There are wheels on the back corners of the printer. Lift up the front of the printer to move it back and forth.

📖 Note

- You can load A3+ (13" x 19"), A3, B4, A4, B5, A5, Letter, Legal, 11" x 17" / 279.4 x 431.8 mm (Tabloid), Wide (4" x 7.1"), 4" x 6" / 10 x 15 cm, 4" x 8" / 101.6 x 203.2 mm, 5" x 7" / 13 x 18 cm, 8" x 10" / 20 x 25 cm, 10" x 12" / 25 x 30 cm, and 14" x 17" / 36 x 43 cm sizes of paper in the Front Tray.
- When printing on paper other than 14" x 17" / 36 x 43 cm size from a PictBridge compliant device, load paper in the Rear Tray.
For details on paper that can be used for a PictBridge compliant device, refer to the on-screen manual: [Advanced Guide](#).

1. Set the Front Tray in the front paper feeding position.

- (1) Gently press the upper center of the Front Tray to open it.



- (2) Tilt the Front Tray upward.

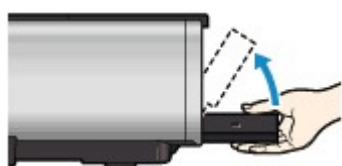

- (3) Lift the Front Tray until it stops.
The **Front Feed** button lights.

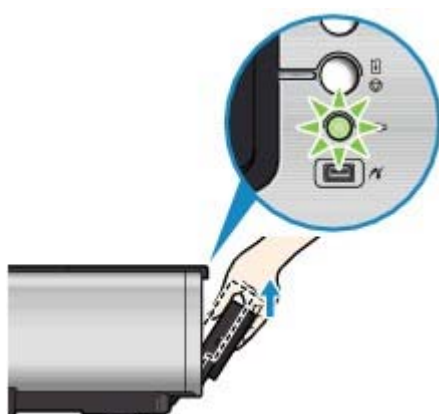

- (4) While keeping the Front Tray lifted, tilt the Front Tray forward to set it in the front paper feeding position.

- (5) Make sure that the **Front Feed** button is lit.

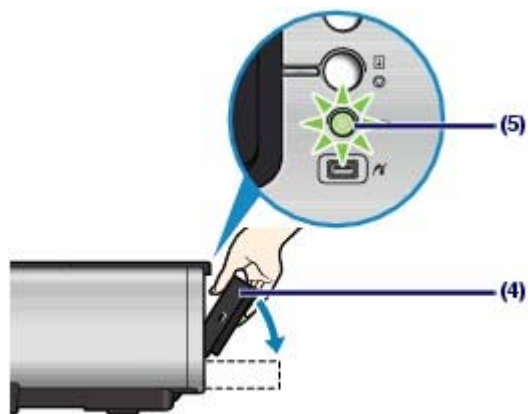

2. Press the **Front Feed Support** button to open the Front Feed Support.

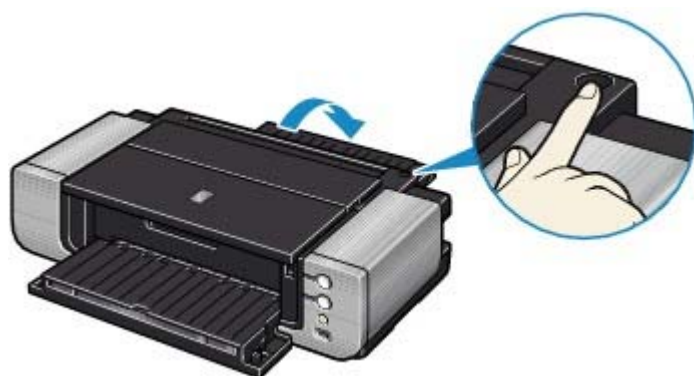

3. Prepare for loading paper.

- (1) Pull out the Front Tray Extension.
 (2) Press the right corner of the Front Feed Support to open the V-shaped Support.

Note

- When loading A4 or smaller size paper, this procedure is not necessary.

- (3) Press the **Front Feed** button.

The printer starts making operating noise, then the **Power** lamp flashes for about 30 seconds.

Important

- Do not load paper when the **Power** lamp is flashing. Otherwise, the paper or the printer may be damaged.

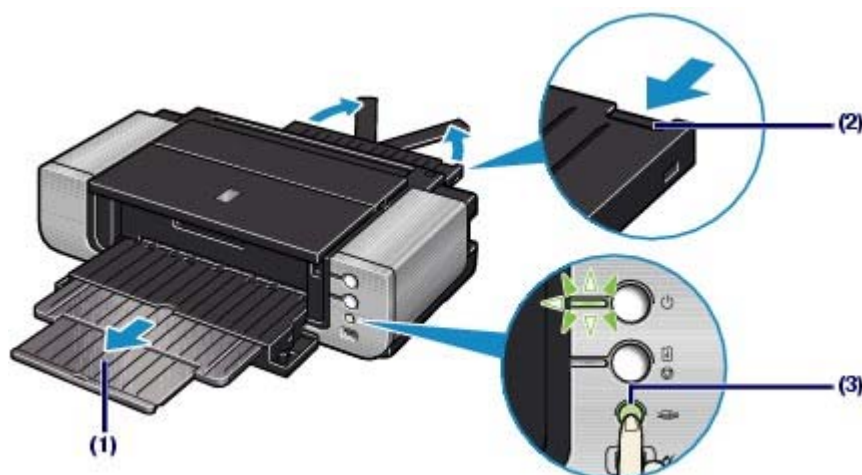

4. Load paper.

- (1) Make sure that the **Power** lamp is lit and the **Front Feed** button is flashing quickly.

If the **Power** lamp is flashing, wait until it stops flashing and stays lit.

- (2) Load the paper straight into the Front Tray WITH THE PRINT SIDE FACING UP.

Align the front edge of the paper with the mark  (Paper Alignment Mark) on the Front Tray.

Load only one sheet of paper in the Front Tray at a time.

Note

- Align the right edge of the paper with the right side (A) of the Front Tray and load the paper straight into the Front Tray.
- If paper is curled, hold the curled corners and gently bend them in the opposite direction until the paper becomes completely flat.
For details on how to flatten curled paper, refer to "[Troubleshooting](#)" in the on-screen manual: *Advanced Guide*.

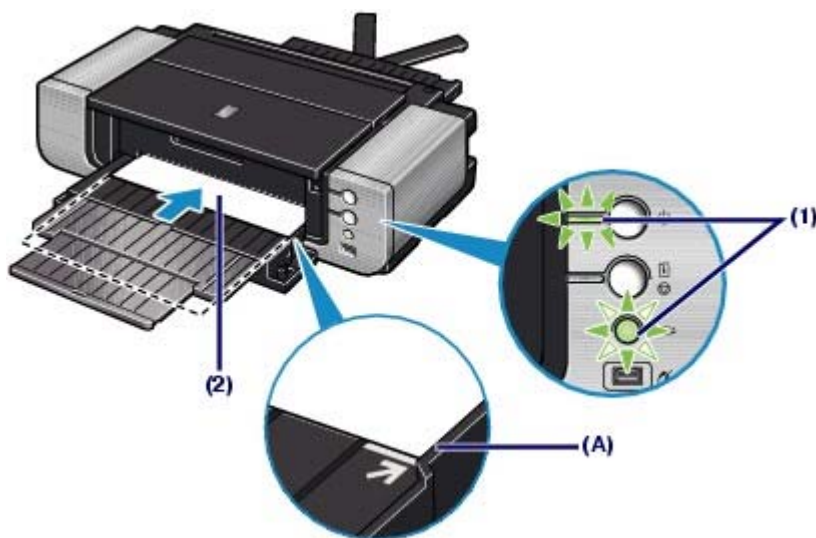

Important

- If the printer is not used for about 5 minutes while it is as described in (1) in step 4 above, the **Front Feed** button stops flashing and stays lit, and you cannot load the paper in the Front Tray. In this case, return to (3) in step 3.

5. Press the **Front Feed** button to feed the paper from the Front Tray.

The paper feeds into the printer automatically and the **Front Feed** button flashes slowly.

The printer is ready to start printing.

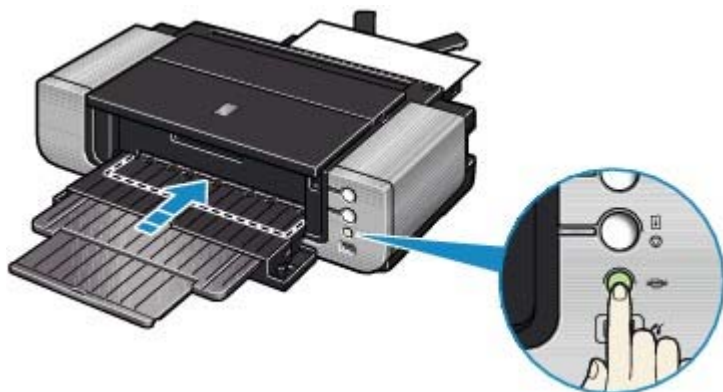

Note

After loading paper

- Select the size and type of the loaded paper in Printer Paper Size (or Paper Size) and Media Type in the printer driver.

See [Printing Documents \(Windows\)](#) or [Printing Documents \(Macintosh\)](#).

To print continuously

- To print from the Front Tray again, return to (3) in step 3 and load paper in the Front Tray. Then start printing.

● Returning the Front Tray to Its Normal Printing Position

When using the Rear Tray, set the Front Tray to its normal printing position.

● Important

- Be sure to follow the procedure below when returning the Front Tray to its normal printing position. Otherwise, the printer may be damaged.
- When the Front Tray is set to the front paper feeding position, printing by using the Rear Tray is not possible. Be sure to set it to its normal printing position.

1. Hold the Front Tray and slowly tilt it like you are closing it.

Tilting the Front Tray lowers it to its normal printing position.

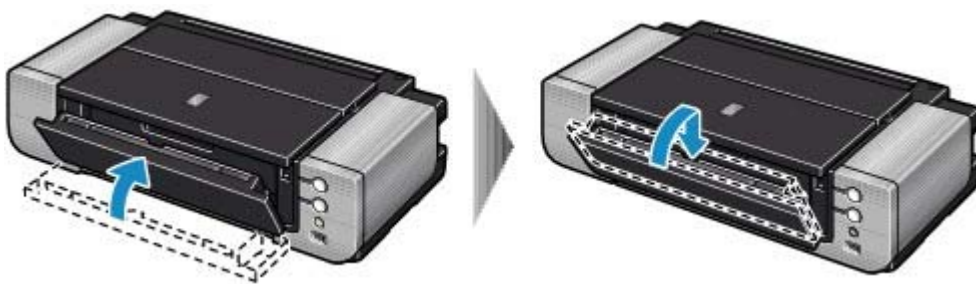

2. Open the Front Tray.

(1) Open the Front Tray to return it to its normal printing position.

(2) Make sure that the **Front Feed** button is not lit.

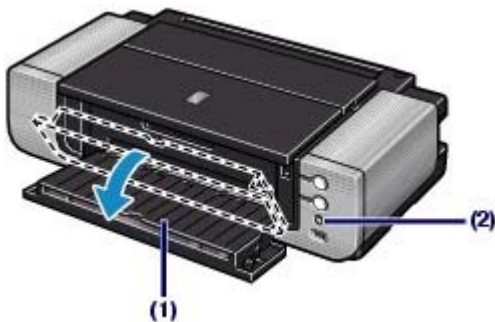

Media Types You Can Use

Choose paper suitable for printing, for the best print results. Canon provides you various types of paper to enhance the fun of printing, such as stickers as well as papers for photo or document. We recommend the use of Canon genuine paper for printing your important photos.



Media Types

Commercially available papers

Name of Paper < Model No.> *1	Paper Source Load Limit		Paper Output Load Limit *2	Settings in Printer Driver: Media Type
	Rear Tray	Front Tray		
Plain Paper (Recycled paper) *3	Approx. 150 sheets*4	1 sheet	Approx. 50 sheets	Plain Paper
Envelopes	10 envelopes	Not loadable*5	*6	Envelope

Canon genuine papers

Name of Paper <Model No.> *1	Paper Source Load Limit		Paper Output Load Limit *2	Settings in Printer Driver: Media Type
	Rear Tray	Front Tray		
For printing photos:				
				
Photo Paper Pro Platinum <PT-101>*7	A3+ (13" x 19") and 10" x 12" / 25 x 30 cm: 1 sheet		*6	Photo Paper Pro Platinum
Photo Paper Pro II <PR-201>*7	A3, A4, Letter, 5" x 7" / 13 x 18 cm, and 8" x 10" / 20 x 25 cm: 10 sheets			Photo Paper Pro II
Glossy Photo Paper "Everyday Use" <GP-501>*7	4" x 6" / 10 x 15 cm: 20 sheets			Glossy Photo Paper
Photo Paper Glossy <GP-502>*7				Glossy Photo Paper
Photo Paper Plus Glossy II <PP-201>*7				Photo Paper Plus Glossy II
Photo Paper Plus Semi-gloss <SG-201>*4 *7				Photo Paper Plus Semi-gloss
Matte Photo Paper <MP-101>				Matte Photo Paper
Fine Art Paper "Photo Rag" <FA-PR1>	1 sheet	1 sheet		Fine Art "Photo Rag"
Fine Art Paper "Museum Etching" <FA-MF1>*8	Not loadable*9		Fine Art "Museum Etching"	

Fine Art Paper Premium Matte <FA-PM1>*8	Not loadable*9			Fine Art Premium Matte
For printing business documents: 				
High Resolution Paper <HR-101N>	A3+ (13" x 19"): 20 sheets A3: 50 sheets A4 and Letter: 80 sheets	1 sheet	50 sheets	High Resolution Paper
For creating your own prints: 				
T-Shirt Transfers <TR-301>	1 sheet	1 sheet	*6	T-Shirt Transfers
Photo Stickers <PS-101>*10				Glossy Photo Paper

*1 Paper with a Model Number is Canon genuine paper. Refer to the instruction manual supplied with the paper for detailed information on the printable side and notes on handling paper. For information on the page sizes available for each Canon genuine paper, visit our website. You may not be able to purchase some Canon genuine papers depending on the country or region of purchase. Paper is not sold in the US by Model Number. Purchase paper by name.

*2 Maximum number of sheets that can be ejected and stacked on the Front Tray when feeding paper from the Rear Tray.

When feeding paper from the Front Tray, remove each sheet as it is ejected.

*3 Proper feeding of paper may not be possible at the maximum capacity depending on the type of paper or environmental conditions (either very high or low temperature or humidity). In such cases, reduce the number of paper you load at a time to less than half (100% recycled paper can be used).

*4 14" x 17" / 36 x 43 cm paper cannot be loaded in the Rear Tray.

*5 Feeding this paper from the Front Tray can damage the printer. Always load in the Rear Tray.

*6 We recommend that you remove the previously printed sheet from the Front Tray before continuously printing to avoid blurs and discoloration.

*7 When loading paper in stacks, the print side may become marked as it is fed or paper may not feed properly. In this case, load one sheet at a time.

*8 If you are using Fine Art Paper "Museum Etching" or Fine Art Paper Premium Matte, you cannot print in the 1.38 inches / 35 mm margin on the top and bottom edges according to the direction of printing. If you select a special page size for Fine Art Paper in the printer driver, a limit is set to prevent printing in the 1.38 inches / 35 mm margin on the top and bottom edges of the paper. We recommend checking the printing area in the preview screen before printing.

For details, refer to the on-screen manual: [Advanced Guide](#).

Canon genuine media is produced and managed to get optimal print quality. We recommend using Canon genuine media.

*9 Feeding this paper from the Rear Tray can damage the printer. Always load in the Front Tray.

*10 You can easily specify print settings for sticker paper with Easy-PhotoPrint EX provided on the *Setup CD-ROM*. Install it on your computer.

Non-Canon genuine specialty paper

● Loading paper

Load one sheet at a time in both the Rear Tray and the Front Tray.



Important

- If you select Canvas or Board Paper in Media Type in the printer driver, always load the paper in the Front Tray. The paper cannot be fed from the Rear Tray.

● Printer driver settings and paper source

Characteristics	Media Type	Page Size /	Paper Source	
				Front

		Paper Size	Rear Tray	Tray
Paper that has the texture of drawing paper	Other Fine Art Paper	Art XX (Margin 35 mm) *1	Available *2	Available
Paper that has a texture like canvas	Canvas	Art XX (Margin 35 mm) *1	Unavailable	Available
Board Paper, Thick paper (From 23 mil / 0.6 mm to 47 mil / 1.2 mm)	Board Paper *3	Art XX (Margin 35 mm) *1	Unavailable	Available

*1 Select Art A4 (Margin 35), Art Letter (Margin 35) / Art US Letter (Margin 35), Art A3 (Margin 35), or Art A3+ 13x19 (Margin 35) according to the size you are using.

For details on the printable area, refer to the on-screen manual: [Advanced Guide](#).

*2 Less than 53 lb / 200 gsm

*3 Be sure to select Board Paper in Media Type. Selecting other media types may cause a malfunction.

Note

- Other than Canon genuine specialty paper, alternative paper types listed on our website may provide better quality printing. For more information about the alternative paper, see your local retailer's homepage listed on the Canon Inc. website.
Please note that the customer must bear the cost for connection to the Internet.
Information regarding the alternative paper is updated on an irregular basis. And alternative products may change without prior announcement.

● Page Sizes

You can use the following sizes of paper.

- You can load paper of the following sizes in the Rear Tray.
A3+ (13" x 19"), A3, B4, A4, B5, A5, Letter, Legal, 11" x 17" / 279.4 x 431.8 mm (Tabloid), Wide (4" x 7.1"), 4" x 6" / 10 x 15 cm, 4" x 8" / 101.6 x 203.2 mm, 5" x 7" / 13 x 18 cm, 8" x 10" / 20 x 25 cm, 10" x 12" / 25 x 30 cm, and envelopes
- You can load paper of the following sizes in the Front Tray.
A3+ (13" x 19"), A3, B4, A4, B5, A5, Letter, Legal, 11" x 17" / 279.4 x 431.8 mm (Tabloid), Wide (4" x 7.1"), 4" x 6" / 10 x 15 cm, 4" x 8" / 101.6 x 203.2 mm, 5" x 7" / 13 x 18 cm, 8" x 10" / 20 x 25 cm, 10" x 12" / 25 x 30 cm, and 14" x 17" / 36 x 43 cm
- In Macintosh, Choukei 3 and Choukei 4 are not available.

Standard sizes:

- Letter (8.50 x 11.00 inches / 215.9 x 279.4 mm)
- Legal (8.50 x 14.00 inches / 215.9 x 355.6 mm)
- 11" x 17" / Tabloid (11.00 x 17.00 inches / 279.4 x 431.8 mm)
- A5 (5.83 x 8.27 inches / 148.0 x 210.0 mm)
- A4 (8.27 x 11.69 inches / 210.0 x 297.0 mm)
- A3 (11.69 x 16.54 inches / 297.0 x 420.0 mm)
- A3+ (13.00 x 19.00 inches / 329.0 x 483.0 mm)
- B5 (7.17 x 10.12 inches / 182.0 x 257.0 mm)
- B4 (10.12 x 14.33 inches / 257.0 x 364.0 mm)
- 4" x 6" (4.00 x 6.00 inches / 10 x 15 cm)
- 4" x 8" (4.00 x 8.00 inches / 101.6 x 203.2 mm)
- 5" x 7" (5.00 x 7.00 inches / 13 x 18 cm)
- 8" x 10" (8.00 x 10.00 inches / 20 x 25 cm)
- 10" x 12" (10.00 x 12.00 inches / 25 x 30 cm)
- 14" x 17" (14.00 x 17.00 inches / 36 x 43 cm)
- L (3.50 x 5.00 inches / 89.0 x 127.0 mm)
- 2L (5.00 x 7.01 inches / 127.0 x 178.0 mm)
- Hagaki (3.94 x 5.83 inches / 100.0 x 148.0 mm)
- Hagaki 2 (7.87 x 5.83 inches / 200.0 x 148.0 mm)
- Comm. Env. #10 (4.12 x 9.50 inches / 104.6 x 241.3 mm)
- DL Env. (4.33 x 8.66 inches / 110.0 x 220.0 mm)
- Choukei 3 (4.72 x 9.25 inches / 120.0 x 235.0 mm)
- Choukei 4 (3.54 x 8.07 inches / 90.0 x 205.0 mm)
- Youkei 4 (4.13 x 9.25 inches / 105.0 x 235.0 mm)
- Youkei 6 (3.86 x 7.48 inches / 98.0 x 190.0 mm)
- Wide (4.00 x 7.10 inches / 101.6 x 180.6 mm)
- Art Letter (Margin 35) (8.50 x 11.00 inches / 215.9 x 279.4 mm)

- Art A4 (Margin 35) (8.27 x 11.69 inches / 210.0 x 297.0 mm)
- Art A3 (Margin 35) (11.69 x 16.54 inches / 297.0 x 420.0 mm)
- Art A3+ (Margin 35) (13.00 x 19.00 inches / 329.0 x 483.0 mm)

Non-standard sizes:

You can also specify a custom size within the following range.

- Minimum size: 3.50 x 5.00 inches / 89.0 x 127.0 mm (Rear Tray)
3.94 x 5.83 inches / 100.0 x 148.0 mm (Front Tray)
- Maximum size: 12.95 x 26.61 inches / 329.0 x 676.0 mm (Rear Tray)
14.00 x 23.00 inches / 355.6 x 584.2 mm (Front Tray)

● Paper Weight / Thickness

Rear Tray:

From 17 lb / 64 gsm to 28 lb / 105 gsm (plain paper except for Canon genuine paper)

Do not use heavier or lighter paper (except for Canon genuine paper), as it could jam in the printer.

However, you can use non-Canon genuine art paper that is up to 53 lb / 200 gsm.

See [Non-Canon genuine specialty paper](#).

Front Tray:

From 4 mil / 0.1 mm to 47 mil / 1.2 mm

Do not use paper thicker than this, as it could jam in the printer.



[↑ Page top](#)

■ Media Types You Cannot Use

Do not use the following types of paper. Using such paper will not only produce unsatisfactory results, but can also cause the printer to jam or malfunction.

- Folded, curled, or wrinkled paper
- Damp paper
- Paper that is too thin
 - Rear Tray: Less than 17 lb / 64 gsm
 - Front Tray: Less than 4 mil / 0.1 mm
- Paper that is too thick
 - Rear Tray: More than 28 lb / 105 gsm (plain paper except for Canon genuine paper)
 - * However, you can use non-Canon genuine art paper that is up to 53 lb / 200 gsm.
 - See [Non-Canon genuine specialty paper](#).
 - Front Tray: More than 47 mil / 1.2 mm
- Paper thinner than a postcard, including plain paper or notepad paper cut to a small size (when printing on A5 or smaller sized paper)
- Picture postcards
- Postcards affixed with photos or stickers
- Envelopes with a double flap (or sticker flaps)
- Envelopes with an embossed or treated surface
- Envelopes whose gummed flaps are already moistened and adhesive
- Any type of paper with holes
- Paper that is not rectangular
- Paper bound with staples or glue
- Paper with adhesives
- Paper decorated with glitter, etc.



■ Handling Paper

- Be careful not to rub or scratch the surfaces of any types of paper when handling.
- Hold the paper as closely as possible to its edges and try not to touch the printing surface. The print quality may be degraded if the printing surface is smudged with sweat or oil that comes from your hands.
- Take out only the necessary number of paper from the package, just before printing.
- To avoid curling, when you do not print, put unused paper back into the package and keep it on a level surface. And also, store it avoiding heat, humidity, and direct sunlight.



 [Page top](#)

Routine Maintenance

This section describes how to replace ink tanks when they run out of ink, to clean the printer when the print result is faint, or to take an action when paper does not feed properly.

Replacing an Ink Tank

- [Replacing Procedure](#)
- [Checking the Ink Status](#)

When Printing Becomes Faint or Colors Are Incorrect

- [Printing the Nozzle Check Pattern](#)
- [Examining the Nozzle Check Pattern](#)
- [Cleaning the Print Head](#)
- [Cleaning the Print Head Deeply](#)
- [Aligning the Print Head](#)

Cleaning the Paper Feed Rollers

Opening the Maintenance Screens

- [Opening the Printer Driver Setup Window \(Windows\)](#)
- [Opening the Canon IJ Printer Utility \(Macintosh\)](#)



Replacing an Ink Tank

When ink runs out while printing is in progress, the **Alarm** lamp flashes orange four times and the error message will appear on your computer screen. Make sure which ink tank has run out of ink and replace it with a new one.

Note

- When ink runs out or other errors occur, the **Alarm** lamp flashes orange to inform you of the error. Refer to "Four flashes:" of "Alarm Lamp Flashes Orange" in "[Troubleshooting](#)" of the on-screen manual: *Advanced Guide*, and take an appropriate action.
- For information on the compatible ink tanks, refer to the printed manual: *Getting Started*.
- If print results become faint or white streaks appear despite sufficient ink levels, see [When Printing Becomes Faint or Colors Are Incorrect](#).

■ Replacing Procedure

When the ink tanks run out of ink, follow the procedure below to replace them.

Important

Handling ink

- To maintain optimal print quality, we recommend the use of specified Canon brand ink tanks. Refilling ink is not recommended.
- If you remove an ink tank, replace it immediately. Do not leave the printer with ink tanks removed.
- Use new ink tanks for replacement. Installing used ink tanks may cause the nozzles to clog. Furthermore, with such ink tanks, the printer will not be able to inform you when to replace the ink tanks properly.
- Once an ink tank has been installed, do not remove it from the printer and leave it out in the open. This will cause the ink tank to dry out, and the printer may not operate properly when it is reinstalled. To maintain optimal printing quality, use an ink tank within six months of first use.

Note

- Color ink may be consumed even when printing a black-and-white document or when black-and-white printing is specified. Every ink is also consumed in the standard cleaning and deep cleaning of the Print Head, which may be necessary to maintain the printer's performance. When an ink tank is out of ink, replace it immediately with a new one.

1. Make sure that the power is turned on, and open the Front Tray gently.

Gently press the upper center of the Front Tray to open it.

2. Open the Top Cover.

The Print Head Holder moves to the replacement position.

Caution

- Do not hold the Print Head Holder to stop or move it forcibly. Do not touch the Print Head Holder until it stops completely.

Important

- Do not touch the metallic parts or other parts inside the printer.
- If the Top Cover is left open, the Print Head Holder moves to the right. In this case, close and reopen the Top Cover.
- If you open the Top Cover while the **Front Feed** button is flashing quickly, the Print Head Holder may not move to the replacement position. In this case, close the Top Cover, press the **Front Feed** button, then wait until the **Front Feed** button stops flashing and stays lit. To continue printing from the Front Tray after replacing the ink tank, follow the procedure from (3) in step 3 in [Loading Paper in the Front Tray](#) and start printing again.
- Do not open the Inner Cover (A) when replacing the ink tank. If the Inner Cover is open after

replacing the ink tank, be sure to close it.



3. Replace the ink tank with the lamp flashing fast.

Push the tab (B) and lift the ink tank to remove.

Do not touch the Print Head Lock Lever (C).

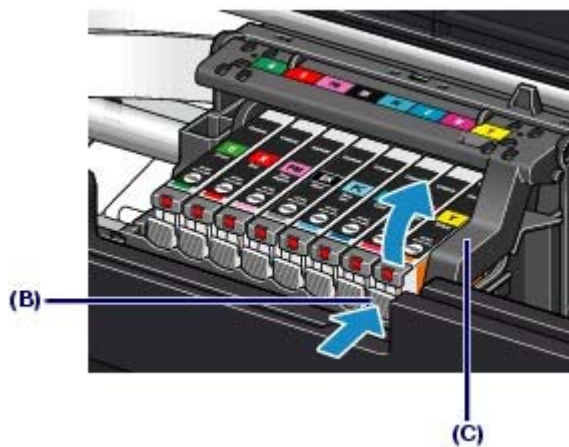

Important

- Handle the ink tank carefully to avoid staining of clothing or the surrounding area.
- Discard the empty ink tank according to the local laws and regulations regarding disposal of consumables.

Note

- Do not remove two or more ink tanks at the same time. Be sure to replace ink tanks one by one when replacing two or more ink tanks.
- For details on ink lamp flashing speed, see [Checking the Ink Status](#).

4. Prepare the new ink tank.

(1) Take the new ink tank out of its package, pull the orange tape (1) in the direction of the arrow to peel it off, then remove the film (2).

Important

- Make sure that the film is completely removed from the air hole (D). If the air hole is blocked with the remaining film, ink may leak out or may not eject properly.

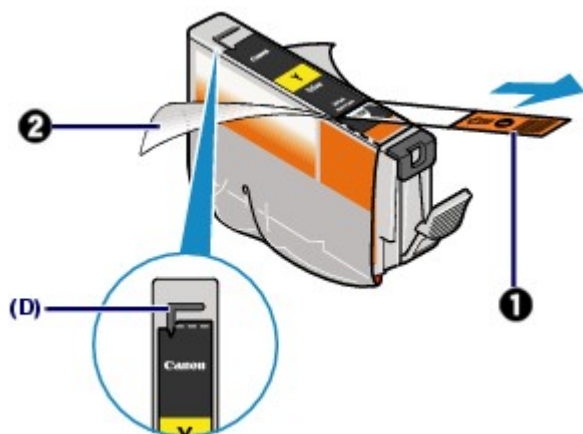

- (2) Hold the orange protective cap (E) as indicated in the figure below, then twist and remove it from the bottom of the ink tank.

Remove the protective cap while holding it to prevent the ink from staining your fingers.

Discard the protective cap once it is removed.

Important

- Do not touch the electrical contacts (F) on the ink tank. It can cause the printer to malfunction or become unable to print.

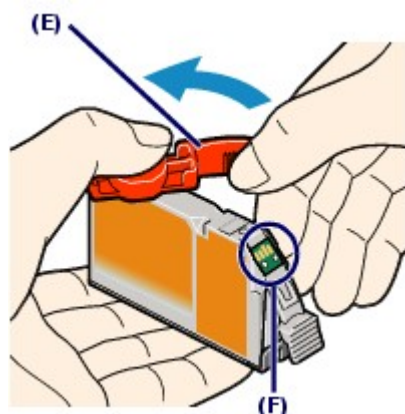

Important

- If you shake the ink tank, the ink may spill out and stain your hands and the surrounding area. Be careful to handle the ink tank.
- Do not squeeze the side of ink tanks as this may cause the ink to leak out.
- Be careful not to stain your hands and the surrounding area with ink on the removed protective cap.
- Do not reattach the protective cap once you have removed it. Discard it according to the local laws and regulations regarding disposal of consumables.
- Do not touch the open ink port once the protective cap is removed, as this may prevent the ink from being ejected properly.

5. Install the new ink tank.

- (1) Insert the front end of ink tank into the Print Head at a slant.

Make sure that the position of the ink tank matches the label.

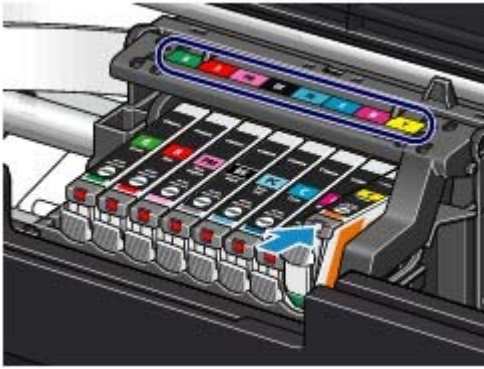

- (2) Press the mark  (Push) on the ink tank until the ink tank snaps firmly into place.

Make sure that the ink lamp lights up red.

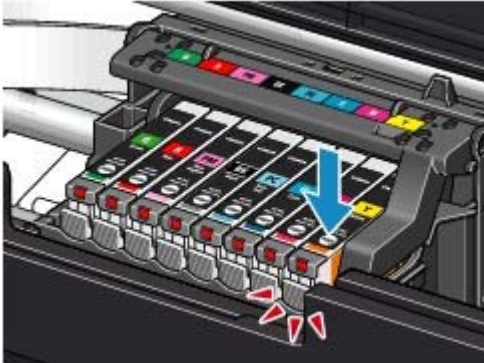

Important

- You cannot print if the ink tank is installed in the wrong position. Be sure to install the ink tank in the correct position according to the label on the Print Head Holder.
- You cannot print unless all the ink tanks are installed. Be sure to install all the ink tanks.

6. Close the Top Cover.

Note

- If the **Alarm** lamp still flashes orange after the Top Cover is closed, refer to "Alarm Lamp Flashes Orange" in "[Troubleshooting](#)" of the on-screen manual: *Advanced Guide*.
- When you start printing after replacing the ink tank, the printer starts cleaning the Print Head automatically. Do not perform any other operations until the printer completes the cleaning of the Print Head. The **Power** lamp flashes green while cleaning.
- If printed ruled lines are misaligned or the print head position is misaligned, adjust the print head position.
See [Aligning the Print Head](#).



■ Checking the Ink Status

You can check the ink status with the ink lamps or your computer screen.

● With the Ink Lamps

1. Make sure that the power is turned on, and open the Front Tray gently.

Gently press the upper center of the Front Tray to open it.

2. Open the Top Cover.

3. Check the ink lamps.



● Ink lamp is on

The ink tank is correctly installed and there is sufficient ink left for printing.

● Ink lamp is flashing

Flashing slowly (at around 3-second intervals)



Ink is low. You can continue printing for a while, but we recommend you to have a new ink tank available.

Flashing fast (at around 1-second intervals)



The ink tank is installed in the wrong position or it is empty. Make sure that the ink tank is installed in the correct position as indicated by the label on the Print Head Holder. If the position is correct but the lamp flashes, the ink tank is empty. Replace it with a new one.

● Ink lamp is off

The ink tank is not installed properly or the function for detecting the remaining ink level is disabled. If the ink tank is not installed properly, press the mark  (Push) on the ink tank until the ink tank clicks into place. If it does not click into place, make sure that the orange protective cap has been removed from the bottom of the ink tank. If the function for detecting the remaining ink level is disabled, replace the ink tank with a new one.

See [Replacing Procedure](#).

If the ink lamp is still off after reinstalling the ink tank, there has been an error and the printer cannot print. Check the **Alarm** lamp on the printer.

Refer to "[Troubleshooting](#)" in the on-screen manual: *Advanced Guide*.

● With the Computer Screen

You can confirm the status of each ink tank with the printer status monitor (Windows) or the Canon

IJ Printer Utility (Macintosh).



(A) Check if any symbol appears on the screen.

The ink with ⚠️ (Ink low) is running low. You can continue printing for a while, but we recommend you to have a new ink tank available.



Note

- An error message may appear while printing. Confirm the message and take an appropriate action.

Follow the procedure below to open each of the confirmation screens.



1. Open the printer driver setup window.

See [Opening the Printer Driver Setup Window \(Windows\)](#) .

2. Click View Printer Status on the Maintenance sheet.

To confirm the ink tank information, click the Ink Details menu.



Note

- You can also display the printer status monitor by clicking Canon XXX (where " XXX" is your printer's name) which appears on the taskbar while printing.

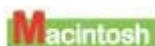

1. Open the Canon IJ Printer Utility dialog box.

See [Opening the Canon IJ Printer Utility \(Macintosh\)](#).

2. Select Ink Level Information in the pop-up menu.

To confirm the ink tank information, click Ink Details.



When Printing Becomes Faint or Colors Are Incorrect

If print results are blurred or colors are not printed correctly, the print head nozzles are probably clogged. Follow the procedure below to print the nozzle check pattern, check the print head nozzle condition, then clean the Print Head.

If printed ruled lines are misaligned or print results are otherwise unsatisfactory, aligning the Print Head may improve print quality.

Important

- Do not rinse or wipe the Print Head and ink tanks. This can cause trouble with the Print Head and ink tanks.

Note

Before performing maintenance

- Open the Top Cover and make sure that all lamps on the ink tanks are lit red. If not, see [Checking the Ink Status](#) and take an appropriate action.
- Increasing the print quality in the printer driver settings may improve the print result. For details, refer to the on-screen manual: [Advanced Guide](#).

● When the Print Results Are Blurred or Uneven:

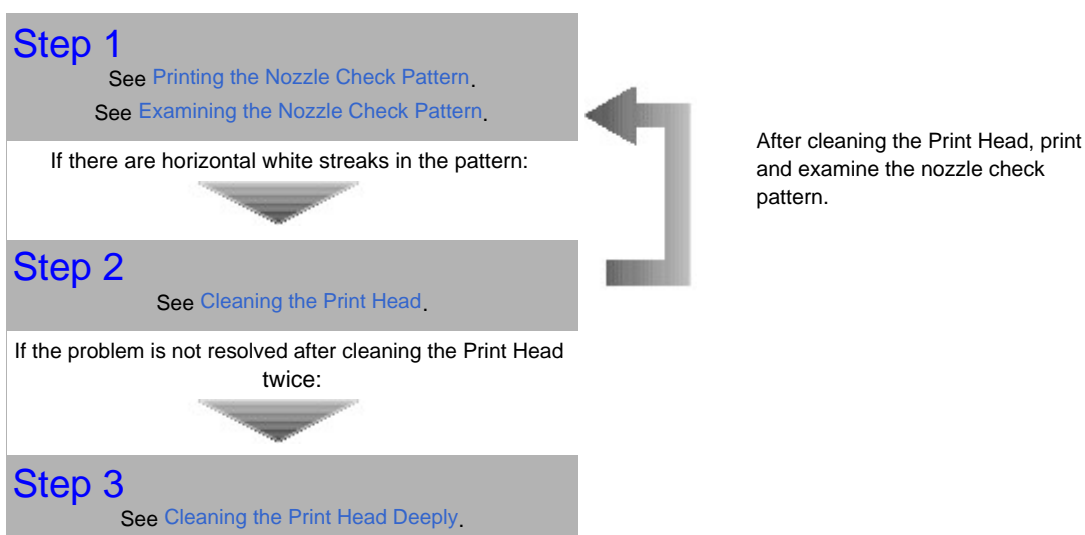

Note

- If you have performed the procedure until step 3 and the problem has not been resolved, turn off the power and clean the Print Head deeply again after 24 hours. If the problem is still not resolved, the Print Head may be damaged. Contact the service center.

● When the Print Results Are Not Even such as the Ruled Lines Are Misaligned:

See [Aligning the Print Head](#).



Basic Guide■ **Advanced Guide** ■ **Troubleshooting**

[Contents](#) > [Routine Maintenance](#) > [When Printing Becomes Faint or Colors Are Incorrect](#) > [Printing the Nozzle Check Pattern](#)

■ Printing the Nozzle Check Pattern

Print the nozzle check pattern to determine whether the ink ejects properly from the print head nozzles.

You need to prepare: a sheet of A4 or Letter-sized plain paper

Note

- If the remaining ink level is low, the nozzle check pattern will not be printed correctly. Replace the ink tank whose ink is low.
See [Replacing an Ink Tank](#).

Printing the nozzle check pattern without a computer

- You can also print the nozzle check pattern from the printer itself using the **RESUME/CANCEL** button.
1. Make sure that the power is turned on, and load a sheet of A4 or Letter-sized plain paper in the Rear Tray.
 2. Gently press the upper center of the Front Tray to open it, and pull out the Front Tray Extension. If the Inner Cover is open, close it.
 3. Hold down the **RESUME/CANCEL** button until the **Power** lamp flashes green twice, then release it immediately. The nozzle check pattern will be printed. Do not perform any other operations until the printer completes the printing of the nozzle check pattern. Examine the nozzle check pattern and take an appropriate action. See step 1 in [Examining the Nozzle Check Pattern](#).
-

Windows

1. Make sure that the power is turned on.
2. Load a sheet of A4 or Letter-sized plain paper in the Rear Tray.

Important

- You cannot feed paper from the Front Tray for printing the nozzle check pattern. Load paper in the Rear Tray.

3. Open the Front Tray gently, and pull out the Front Tray Extension.
Gently press the upper center of the Front Tray to open it.

Important

- If the Inner Cover is open, close it.

4. Open the printer driver setup window.
See [Opening the Printer Driver Setup Window \(Windows\)](#) .

5. Print the nozzle check pattern.
 - (1) Click the Maintenance tab.
 - (2) Click Nozzle Check.

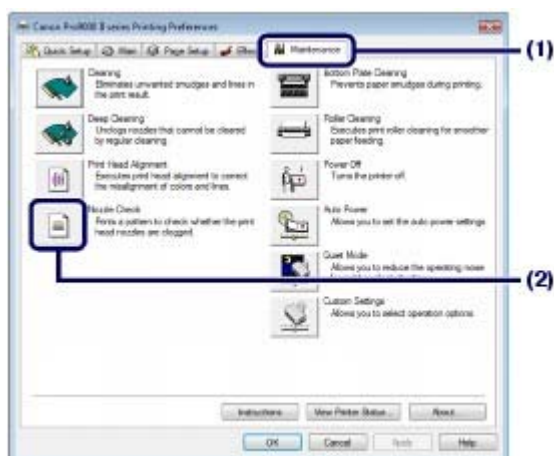

- (3) Confirm the displayed message, and click Print Check Pattern.
The nozzle check pattern will be printed.

Do not perform any other operations until the printer completes the printing of the nozzle check pattern.

Note

- Clicking Initial Check Items displays the items to be checked before printing the nozzle check pattern.

6. Examine the nozzle check pattern.

See [Examining the Nozzle Check Pattern](#).

Macintosh

- Make sure that the power is turned on.
- Load a sheet of A4 or Letter-sized plain paper in the Rear Tray.

Important

- You cannot feed paper from the Front Tray for printing the nozzle check pattern. Load paper in the Rear Tray.

- Open the Front Tray gently, and pull out the Front Tray Extension.

Gently press the upper center of the Front Tray to open it.

Important

- If the Inner Cover is open, close it.

- Open the Canon IJ Printer Utility dialog box.

See [Opening the Canon IJ Printer Utility \(Macintosh\)](#).

- Print the nozzle check pattern.

(1) Select Test Print in the pop-up menu.

(2) Click Nozzle Check.



(3) Confirm the displayed message, and click Print Check Pattern.

The nozzle check pattern will be printed.

Do not perform any other operations until the printer completes the printing of the nozzle check pattern.



Note

- Clicking Initial Check Items displays the items to be checked before printing the nozzle check pattern.

6. Examine the nozzle check pattern.

See [Examining the Nozzle Check Pattern](#).



[↑ Page top](#)

■ Examining the Nozzle Check Pattern

Examine the nozzle check pattern, and clean the Print Head if necessary.

1. Check if there are horizontal white streaks in the pattern (1) and/or pattern (2).

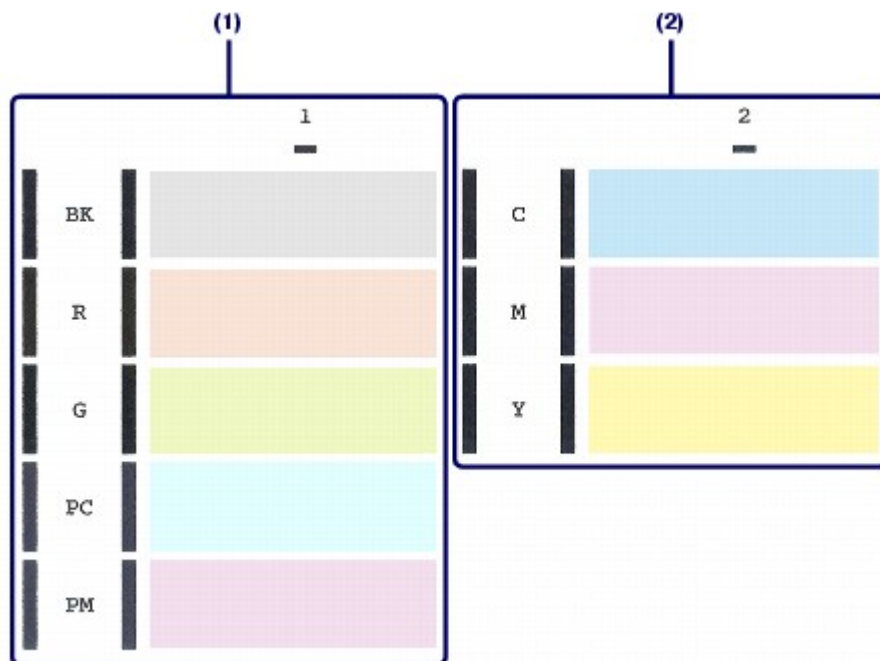

If there are horizontal white streaks in the pattern (1):

Cleaning the print head nozzles of ink group 1 (BK, R, G, PC, or PM) is required.

If there are horizontal white streaks in the pattern (2):

Cleaning the print head nozzles of ink group 2 (C, M, or Y) is required.

If there are horizontal white streaks in both the pattern (1) and pattern (2):

Cleaning the print head nozzles of all ink colors is required.



(A) Good (no horizontal white streaks)

(B) Bad (horizontal white streaks are present)

2. Take the appropriate action.

When cleaning is not required:

Click Exit (Windows) or Quit (Macintosh) on the Pattern Check dialog box to exit nozzle check pattern examination.

When cleaning is required:

- (1) Click Cleaning.



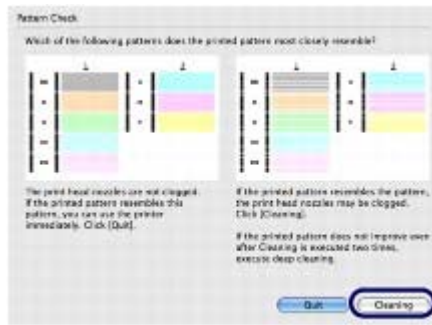
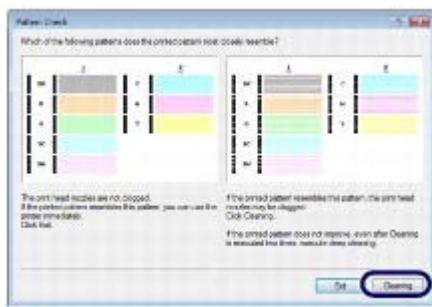

(2) Load a sheet of A4 or Letter-sized plain paper in the Rear Tray.

Follow the procedure from (3) in step 5 (Windows or Macintosh) in [Cleaning the Print Head](#) to clean the Print Head.



Go to [Select the ink group to clean.](#) in "Cleaning the Print Head".



Go to [Select the ink group to clean.](#) in "Cleaning the Print Head".



[↑ Page top](#)

■ Cleaning the Print Head

Clean the Print Head if there are horizontal white streaks in the printed nozzle check pattern. Cleaning unclogs the nozzles and restores the print head condition. Cleaning the Print Head consumes ink, so clean the Print Head only when necessary.

You need to prepare: a sheet of A4 or Letter-sized plain paper

Note

Cleaning the Print Head without a computer

- You can also clean the Print Head (print head nozzles of all ink colors) from the printer itself using the **RESUME/CANCEL** button.
 1. Make sure that the power is turned on.
 2. Hold down the **RESUME/CANCEL** button until the **Power** lamp flashes green once, then release it immediately. The printer starts cleaning the Print Head. When the **Power** lamp is lit green after flashing, the cleaning will be completed. Print the nozzle check pattern to check the print head condition after cleaning. See [Printing the Nozzle Check Pattern](#).

Windows

If you click Cleaning on the Pattern Check dialog box that appears after printing the nozzle check pattern, the printer starts cleaning the Print Head. Load a sheet of A4 or Letter-sized plain paper in the Rear Tray, then go to (3) in step 5.

1. Make sure that the power is turned on.
2. Load a sheet of A4 or Letter-sized plain paper in the Rear Tray.

Important

- You cannot feed paper from the Front Tray for printing the nozzle check pattern. Load paper in the Rear Tray.

3. Open the Front Tray gently, and pull out the Front Tray Extension.

Gently press the upper center of the Front Tray to open it.

Important

- If the Inner Cover is open, close it.

4. Open the printer driver setup window.

See [Opening the Printer Driver Setup Window \(Windows\)](#) .

5. Clean the Print Head.

- (1) Click the Maintenance tab.
- (2) Click Cleaning.

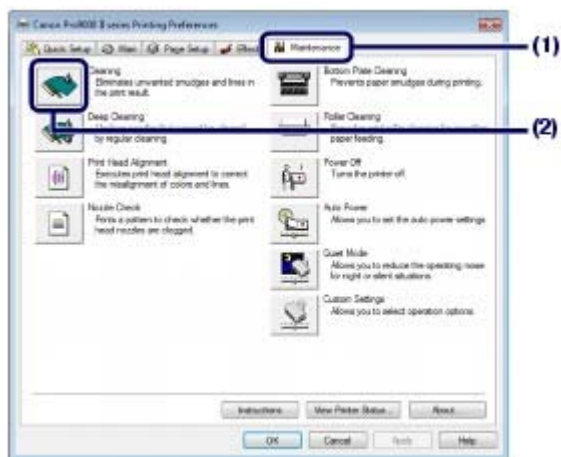

(3) Select the ink group to clean.

Note

- If there are horizontal white streaks in the nozzle check pattern of BK, R, G, PC, or PM, select Group 1. If there are horizontal white streaks in the nozzle check pattern of C, M, or Y, select Group 2. For details on the nozzle check pattern, see [Examining the Nozzle Check Pattern](#).

(4) Click Execute.

The printer starts cleaning the Print Head when the **Power** lamp starts flashing green.

Do not perform any other operations until the printer completes the cleaning of the Print Head. This takes about 1 minute 30 seconds.

Note

- Clicking Initial Check Items displays the items to be checked before cleaning the Print Head.



(5) Confirm the displayed message, and click Print Check Pattern.

The nozzle check pattern will be printed.

Do not perform any other operations until the printer completes the printing of the nozzle check pattern.

6. Check the printed nozzle check pattern.

See [Examining the Nozzle Check Pattern](#).

Note

- If the problem is not resolved after cleaning the Print Head twice, clean the Print Head deeply. See [Cleaning the Print Head Deeply](#).

Macintosh

If you click Cleaning on the Pattern Check dialog box that appears after printing the nozzle check pattern, the printer starts cleaning the Print Head. Load a sheet of A4 or Letter-sized plain paper in the Rear Tray, then go to (3) in step 5.

1. Make sure that the power is turned on.

2. Load a sheet of A4 or Letter-sized plain paper in the Rear Tray.

Important

- You cannot feed paper from the Front Tray for printing the nozzle check pattern. Load paper in the Rear Tray.

3. Open the Front Tray gently, and pull out the Front Tray Extension.

Gently press the upper center of the Front Tray to open it.

Important

- If the Inner Cover is open, close it.

4. Open the Canon IJ Printer Utility dialog box.

See [Opening the Canon IJ Printer Utility \(Macintosh\)](#).

5. Clean the Print Head.

(1) Make sure that Cleaning is selected in the pop-up menu.

(2) Click Cleaning.



(3) Select the ink group to clean.

Note

- If there are horizontal white streaks in the nozzle check pattern of BK, R, G, PC, or PM, select Group1. If there are horizontal white streaks in the nozzle check pattern of C, M, or Y, select Group2.

For details on the nozzle check pattern, see [Examining the Nozzle Check Pattern](#).

(4) Click OK.

The printer starts cleaning the Print Head when the **Power** lamp starts flashing green.

Do not perform any other operations until the printer completes the cleaning of the Print Head. This takes about 1 minute 30 seconds.

Note

- Clicking Initial Check Items displays the items to be checked before cleaning the Print Head.

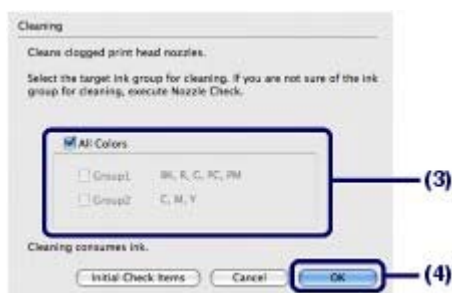

(5) Confirm the displayed message, and click Print Check Pattern.

The nozzle check pattern will be printed.

Do not perform any other operations until the printer completes the printing of the nozzle check pattern.

6. Check the printed nozzle check pattern.

See [Examining the Nozzle Check Pattern](#).

**Note**

- If the problem is not resolved after cleaning the Print Head twice, clean the Print Head deeply.
See [Cleaning the Print Head Deeply](#).



[↑ Page top](#)

[Contents](#) > [Routine Maintenance](#) > [When Printing Becomes Faint or Colors Are Incorrect](#) > [Cleaning the Print Head Deeply](#)

■ Cleaning the Print Head Deeply

If print quality does not improve by the standard cleaning of the Print Head, clean the Print Head deeply. Cleaning the Print Head deeply consumes more ink than the standard cleaning of the Print Head, so clean the Print Head deeply only when necessary.

You need to prepare: a sheet of A4 or Letter-sized plain paper



1. Make sure that the power is turned on.
2. Load a sheet of A4 or Letter-sized plain paper in the Rear Tray.

Important

- You cannot feed paper from the Front Tray for printing the nozzle check pattern. Load paper in the Rear Tray.

3. Open the Front Tray gently, and pull out the Front Tray Extension.
Gently press the upper center of the Front Tray to open it.

Important

- If the Inner Cover is open, close it.

4. Open the printer driver setup window.
See [Opening the Printer Driver Setup Window \(Windows\)](#) .

5. Clean the Print Head deeply.
 - (1) Click the Maintenance tab.
 - (2) Click Deep Cleaning.

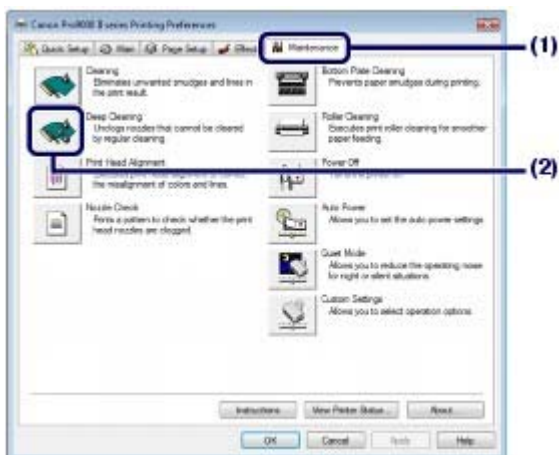

- (3) Select the ink group to clean deeply.

Note

- If there are horizontal white streaks in the nozzle check pattern of BK, R, G, PC, or PM,

select Group 1. If there are horizontal white streaks in the nozzle check pattern of C, M, or Y, select Group 2.

For details on the nozzle check pattern, see [Examining the Nozzle Check Pattern](#).

(4) Click Execute.

Note

- Clicking Initial Check Items displays the items to be checked before cleaning the Print Head deeply.

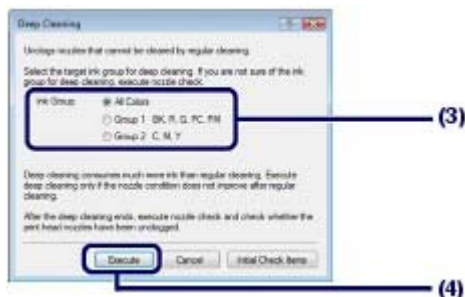

(5) Confirm the displayed message, and click OK.

The printer starts cleaning the Print Head deeply when the **Power** lamp starts flashing green.

Do not perform any other operations until the printer completes the deep cleaning of the Print Head. This takes about 2 minutes.

(6) Confirm the displayed message, and click Print Check Pattern.

The nozzle check pattern will be printed.

Do not perform any other operations until the printer completes the printing of the nozzle check pattern.

6. Check the printed nozzle check pattern.

See step 1 in [Examining the Nozzle Check Pattern](#).

If a particular color is not printed properly, replace the ink tank of that color.

See [Replacing an Ink Tank](#).

If the problem is not resolved, open the Top Cover to confirm that the ink is remaining, turn off the power, then clean the Print Head deeply again after 24 hours.

If the problem is still not resolved, the Print Head may be damaged. Contact the service center.

Macintosh

1. Make sure that the power is turned on.

2. Load a sheet of A4 or Letter-sized plain paper in the Rear Tray.

Important

- You cannot feed paper from the Front Tray for printing the nozzle check pattern. Load paper in the Rear Tray.

3. Open the Front Tray gently, and pull out the Front Tray Extension.

Gently press the upper center of the Front Tray to open it.

Important

- If the Inner Cover is open, close it.

4. Open the Canon IJ Printer Utility dialog box.

See [Opening the Canon IJ Printer Utility \(Macintosh\)](#).

5. Clean the Print Head deeply.

(1) Make sure that Cleaning is selected in the pop-up menu.

(2) Click Deep Cleaning.



(3) Select the ink group to clean deeply.

Note

- If there are horizontal white streaks in the nozzle check pattern of BK, R, G, PC, or PM, select Group1. If there are horizontal white streaks in the nozzle check pattern of C, M, or Y, select Group2. For details on the nozzle check pattern, see [Examining the Nozzle Check Pattern](#).

(4) Click OK.

The printer starts cleaning the Print Head deeply when the **Power** lamp starts flashing green.

Do not perform any other operations until the printer completes the deep cleaning of the Print Head. This takes about 2 minutes.

Note

- Clicking Initial Check Items displays the items to be checked before cleaning the Print Head deeply.

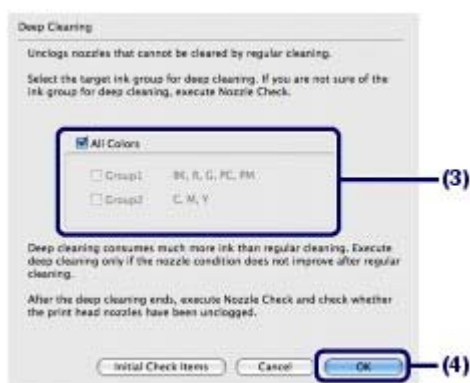

(5) Confirm the displayed message, and click Print Check Pattern.

The nozzle check pattern will be printed.

Do not perform any other operations until the printer completes the printing of the nozzle check pattern.

6. Check the printed nozzle check pattern, and click Quit on the Pattern Check dialog box.

See step 1 in [Examining the Nozzle Check Pattern](#).

If a particular color is not printed properly, replace the ink tank of that color.

See [Replacing an Ink Tank](#).

If the problem is not resolved, open the Top Cover to confirm that the ink is remaining, turn off the power, then clean the Print Head deeply again after 24 hours.

If the problem is still not resolved, the Print Head may be damaged. Contact the service center.



[↑ Page top](#)

■ Aligning the Print Head

If printed ruled lines are misaligned or print results are otherwise unsatisfactory, adjust the print head position.

You need to prepare: two sheets of A4 or Letter-sized plain paper

Note

Aligning the Print Head without a computer

- You can also align the Print Head from the printer itself using the **RESUME/CANCEL** button.
1. Make sure that the power is turned on, and load two sheets of A4 or Letter-sized plain paper in the Rear Tray.
 2. Gently press the upper center of the Front Tray to open it, and pull out the Front Tray Extension. If the Inner Cover is open, close it.
 3. Hold down the **RESUME/CANCEL** button until the **Power** lamp flashes green four times, then release it immediately. The print head alignment pattern will be printed and the printer will adjust the print head position automatically. Do not perform any other operations until the printer completes the printing of the print head alignment pattern.

Windows

1. Make sure that the power is turned on.
2. Load two sheets of A4 or Letter-sized plain paper in the Rear Tray.

Important

- You cannot feed paper from the Front Tray for aligning the Print Head. Load paper in the Rear Tray.

3. Open the Front Tray gently, and pull out the Front Tray Extension.
Gently press the upper center of the Front Tray to open it.

Important

- If the Inner Cover is open, close it.

4. Open the printer driver setup window.
See [Opening the Printer Driver Setup Window \(Windows\)](#) .

5. Adjust the print head position.
 - (1) Click the Maintenance tab.
 - (2) Click Print Head Alignment.

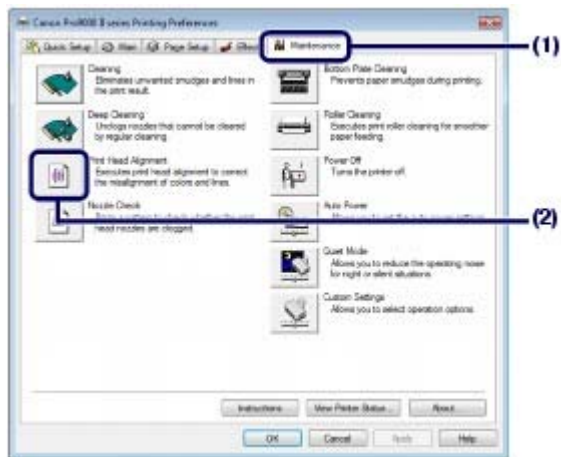

(3) Confirm the displayed message, and click Align Print Head.



The print head alignment pattern will be printed and the printer will adjust the print head position automatically.

Do not perform any other operations until the printer completes the printing of the print head alignment pattern. This takes about 4 minutes.

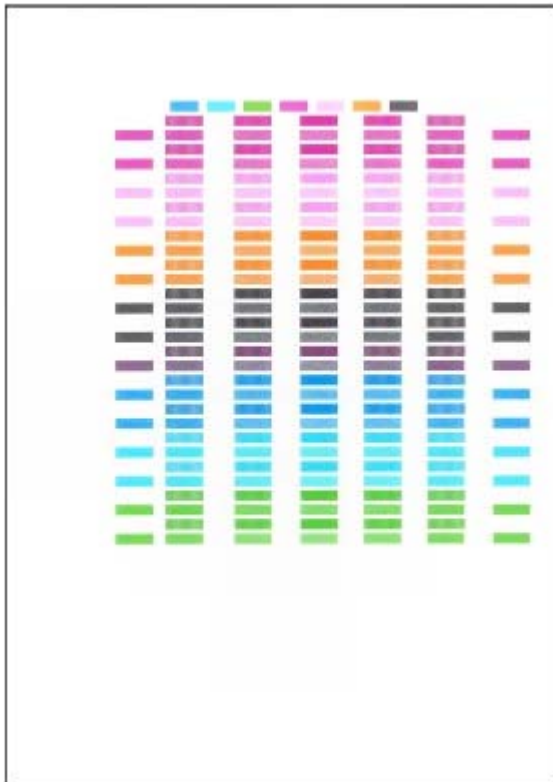

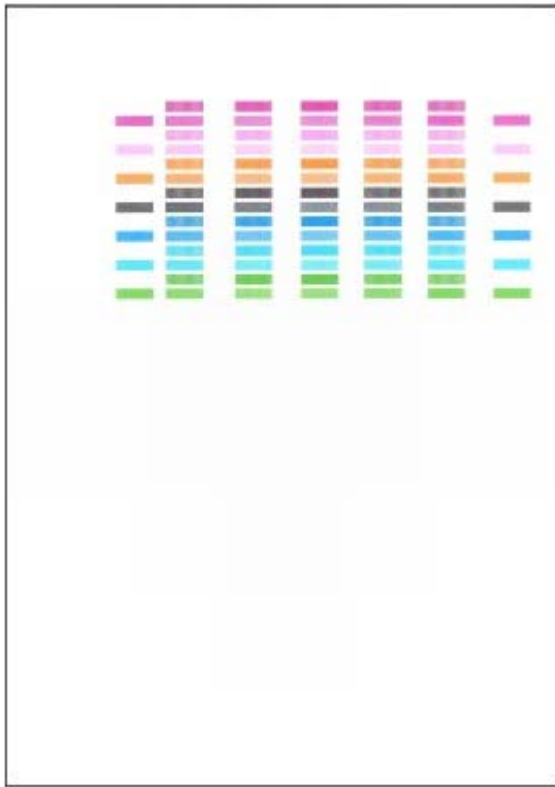

Note

- If the automatic adjustment of the print head position has failed, the **Alarm** lamp flashes. Refer to "Eleven flashes:" of "Alarm Lamp Flashes Orange" in " [Troubleshooting](#) " of the on-screen manual: *Advanced Guide*.
- If the print results are still not satisfactory after adjusting the print head position as described above, align the Print Head manually. Refer to the on-screen manual: [Advanced Guide](#).

Macintosh

1. Make sure that the power is turned on.
2. Load two sheets of A4 or Letter-sized plain paper in the Rear Tray.

Important

- You cannot feed paper from the Front Tray for aligning the Print Head. Load paper in the Rear Tray.

3. Open the Front Tray gently, and pull out the Front Tray Extension.
Gently press the upper center of the Front Tray to open it.

Important

- If the Inner Cover is open, close it.

4. Open the Canon IJ Printer Utility dialog box.
See [Opening the Canon IJ Printer Utility \(Macintosh\)](#).

5. Adjust the print head position.
 - (1) Select Test Print in the pop-up menu.

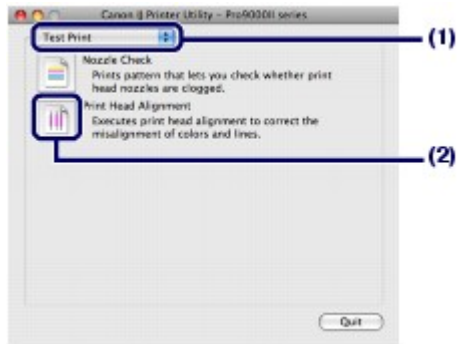
(2) Click Print Head Alignment.**(3)** Confirm the displayed message, and click Align Print Head.

The print head alignment pattern will be printed and the printer will adjust the print head position automatically.

Do not perform any other operations until the printer completes the printing of the print head alignment pattern. This takes about 4 minutes.

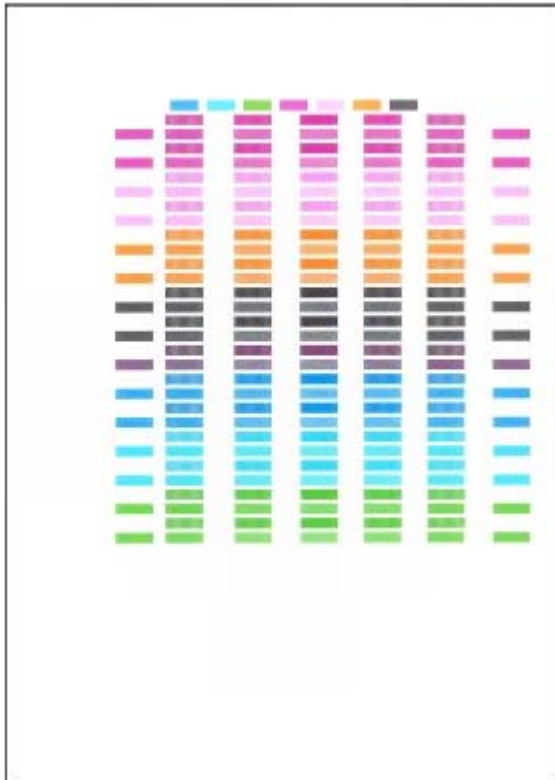

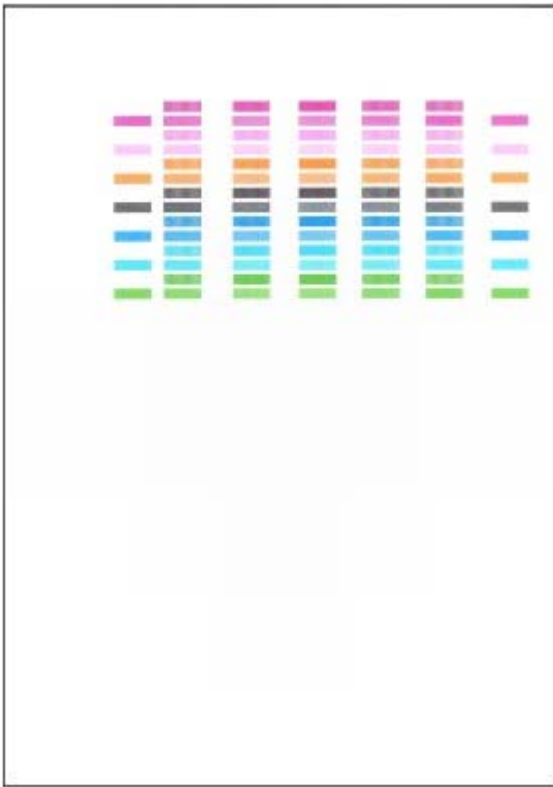

Note

- If the automatic adjustment of the print head position has failed, the **Alarm** lamp flashes. Refer to "Eleven flashes:" of "Alarm Lamp Flashes Orange" in " [Troubleshooting](#) " of the on-screen manual: *Advanced Guide*.
- If the print results are still not satisfactory after adjusting the print head position as described above, align the Print Head manually. Refer to the on-screen manual: [Advanced Guide](#).



[↑ Page top](#)

Cleaning the Paper Feed Rollers

If the Paper Feed Rollers are dirty or paper powder is attached to them, paper may not be fed properly. In this case, clean the Paper Feed Rollers. Cleaning will wear out the Paper Feed Rollers, so perform this only when necessary.

You need to prepare: three sheets of A4 or Letter-sized plain paper



1. Make sure that the power is turned on, and remove any paper from the printer.
2. Open the Front Tray gently, and pull out the Front Tray Extension.
Gently press the upper center of the Front Tray to open it.

Important

- If the Inner Cover is open, close it.

3. Open the printer driver setup window.
See [Opening the Printer Driver Setup Window \(Windows\)](#) .

4. Clean the Paper Feed Rollers.
 - (1) Click the Maintenance tab.
 - (2) Click Roller Cleaning.



- (3) Confirm the displayed message, and click OK.
The Paper Feed Rollers will rotate as they are cleaned.



5. Make sure that the Paper Feed Rollers stop rotating, and load paper when the

message appears.

Load three sheets of A4 or Letter-sized plain paper in the Rear Tray.

Important

- You cannot feed paper from the Front Tray for cleaning the Paper Feed Rollers. Load paper in the Rear Tray.

6. Click OK.

The paper is ejected after cleaning.

Do not perform any other operations until the printer completes the cleaning of the Paper Feed Rollers.

7. When the completion message appears, click OK.

If the problem is not resolved after cleaning the Paper Feed Rollers, contact the service center.

Macintosh

1. Make sure that the power is turned on, and remove any paper from the printer.

2. Open the Front Tray gently, and pull out the Front Tray Extension.

Gently press the upper center of the Front Tray to open it.

Important

- If the Inner Cover is open, close it.

3. Open the Canon IJ Printer Utility dialog box.

See [Opening the Canon IJ Printer Utility \(Macintosh\)](#).

4. Clean the Paper Feed Rollers.

(1) Make sure that Cleaning is selected in the pop-up menu.

(2) Click Roller Cleaning.



(3) Confirm the displayed message, and click OK.

The Paper Feed Rollers will rotate as they are cleaned.



5. Make sure that the Paper Feed Rollers stop rotating, and load paper when the message appears.

Load three sheets of A4 or Letter-sized plain paper in the Rear Tray.

 **Important**

- You cannot feed paper from the Front Tray for cleaning the Paper Feed Rollers. Load paper in the Rear Tray.

6. Click OK.

The paper is ejected after cleaning.

Do not perform any other operations until the printer completes the cleaning of the Paper Feed Rollers.

If the problem is not resolved after cleaning the Paper Feed Rollers, contact the service center.



[↑ Page top](#)

Opening the Maintenance Screens

You can perform maintenance operations from the printer driver setup window (Windows) or the Canon IJ Printer Utility (Macintosh).

■ Opening the Printer Driver Setup Window (Windows)

1. Click Control Panel, and Printer under Hardware and Sound.

When you are using Windows XP

Click Control Panel, Printers and Other Hardware, then Printers and Faxes.

When you are using Windows 2000

Click Control Panel, and Printers.

2. Right-click the Canon XXX icon (where "XXX" is your printer's name), and select Printing Preferences.

The printer driver setup window appears.

Note

- You can also open the printer driver setup window from your software application or My Printer on the desktop.

For details, refer to the on-screen manual: [Advanced Guide](#).

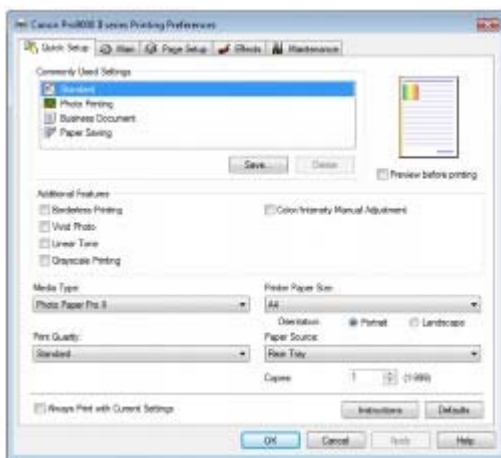

■ Opening the Canon IJ Printer Utility (Macintosh)

When you are using Mac OS X v.10.5.x

1. Open System Preferences, and click Print & Fax.
2. Select your printer's name in Printers, and click Open Print Queue.
The list of print jobs appears.
3. Click Utility.
The Printer List dialog box appears.

4. Select your printer's name in the Product list, and click Maintenance.

The Canon IJ Printer Utility starts up.

Note

When you are using Mac OS X v.10.4.x or Mac OS X v.10.3.9

- Follow the procedure below to open the Canon IJ Printer Utility.

Select Applications from the Go menu, double-click the Utilities folder, then double-click Printer Setup Utility to open the Printer List dialog box. Select your printer's name in the Name list and click Utility, then select your printer's name in the Product list and click Maintenance. The Canon IJ Printer Utility starts up.

For details, refer to the on-screen manual: [Advanced Guide](#).



Appendix

[Legal Limitations on Use of Your Product and Use of Images](#)

[Tips on How to Use Your Printer](#)



[↑ Page top](#)

Legal Limitations on Use of Your Product and Use of Images

It may be unlawful to print the following documents.

The list provided is non-exhaustive. When in doubt, check with a legal representative in your jurisdiction.

- Paper money
- Money orders
- Certificates of deposit
- Postage stamps (canceled or uncanceled)
- Identifying badges or insignias
- Selective service or draft papers
- Checks or drafts issued by governmental agencies
- Motor vehicle licenses and certificates of title
- Traveler's checks
- Food stamps
- Passports
- Immigration papers
- Internal revenue stamps (canceled or uncanceled)
- Bonds or other certificates of indebtedness
- Stock certificates
- Copyrighted works/works of art without permission of copyright owner



[↑ Page top](#)

Tips on How to Use Your Printer

This section introduces the tips on how to use your printer and for printing with optimal quality.

■ Ink is used for various purposes.

● How is ink used for various purposes other than printing?

Ink may be used for purposes other than printing. Ink is not only used for printing, but also for cleaning the Print Head to maintain the optimal printing quality.

The printer has the function to automatically clean the ink jet nozzles to prevent clogging. In the cleaning procedure, ink is pumped out from the nozzles. Used ink for nozzle cleaning is limited to a small amount.

● Does black-and-white printing use color ink?

The use of each ink varies depending on the color of image to be printed or the contents of document. Black-and-white printing may also use ink other than black ink. So, color ink is consumed even when printing in black-and-white.

● Ink lamp indicates when ink is running low.

The inside of the ink tank consists of (A) the part where ink is preserved and (B) the sponge with absorbed ink.

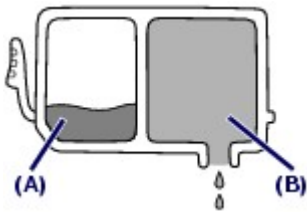

When the ink (A) runs out, the ink lamp flashes slowly to indicate that the ink is running low. Then, when the ink (B) runs out, the ink lamp flashes fast to indicate that the ink tank needs to be replaced with a new one.

See [Replacing an Ink Tank](#).

■ Printing on special paper: How to print with optimal quality!?

● Tip!: Check the printer status before printing!

● Is the Print Head OK?

If print head nozzles are clogged, print will be faint and papers will be wasted. Print the nozzle check pattern to check the Print Head.

See [When Printing Becomes Faint or Colors Are Incorrect](#).

● Is the inside of the printer smeared with ink?

After printing large quantities of paper or performing borderless printing, the area where papers go through may get smeared with ink. Clean the inside of your printer with Bottom Plate Cleaning.

Refer to the on-screen manual: [Advanced Guide](#).

● Tip!: Check how to load the paper correctly!

● Is the paper loaded in the correct orientation?

Load paper in the Rear Tray or Front Tray in the correct orientation.

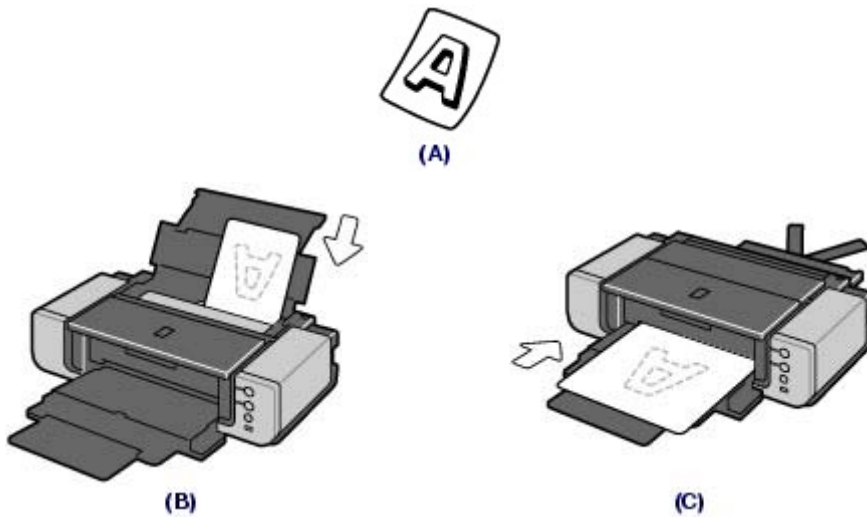

(A) Desired print result

(B) Rear Tray

(C) Front Tray

- Load paper in the Rear Tray with the print side facing you.

- Load paper in the Front Tray with the print side facing up.

● Is the paper loaded in the proper paper source?

Load paper either in the Rear Tray or in the Front Tray, depending on the size or type of paper.

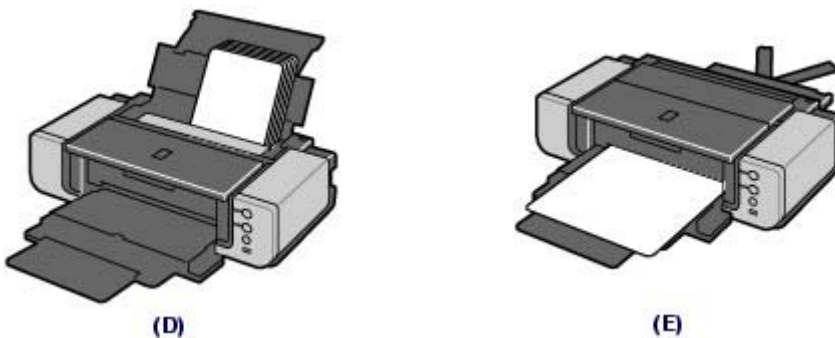

(D) Rear Tray

(E) Front Tray

- You can load various sizes of paper in the Rear Tray. Two or more sheets of the same size and type of paper can be loaded at a time.

- You can load large size paper, such as 14" x 17" / 36 x 43 cm paper, or thick paper in the Front Tray. Only one sheet of paper can be loaded at a time.

● Is the paper curled?

The curled paper causes paper jam. Flatten the curled paper, then reload it.

Refer to "[Troubleshooting](#)" in the on-screen manual: *Advanced Guide*.

● Tip!: After loading paper, be sure to specify the paper settings!

After loading paper, be sure to select the loaded paper in Media Type of the printer driver. If the type of paper is not selected, you may not be able to get the satisfactory print result.

See [Printing Photos / Documents](#) and [Media Types You Can Use](#).

There are various types of paper: paper with special coating on the surface for printing photos with optimal quality and paper suitable for documents. Media Type of the printer driver has different settings for each type of paper in advance (such as using ink, ejecting ink, or distance from nozzles) so that you can print on each paper with the optimal image quality. You can print with different settings in Media Type suitable for each type of loaded paper.

■ Use the RESUME/CANCEL button to cancel printing!

● Tip!: Never press the Power button!

If you press the **Power** button while printing is in progress, the print data sent from the computer queues

in the printer and you may not be able to continue to print.
Press the **RESUME/CANCEL** button to cancel printing.

Note

- If you cannot cancel printing by pressing the **RESUME/CANCEL** button while printing from a computer, open the printer driver setup window to delete the unnecessary print jobs from the printer status monitor (Windows).

■ How to maintain the optimal printing quality?

The key to printing with the optimal printing quality is to prevent the Print Head from drying or clogging.
Always follow the following steps for optimal printing quality.

● Follow the procedure below to disconnect the power plug.

1. Press the **Power** button on the printer to turn it off.
2. Make sure that the **Power** lamp is not lit.
3. Disconnect the power plug from the wall outlet, or turn off the extender cable connector.

If you press the **Power** button to turn off the power, the printer caps the Print Head (nozzles) automatically to prevent from drying. If you disconnect the power plug from the wall outlet or turn off the extender cable connector before the **Power** lamp is turned off, the Print Head will not be capped properly and this will cause drying or clogging.

To disconnect the power plug, be sure to follow this procedure.

● Print periodically!

Just as the tip of a felt pen becomes dry and unusable if it has not been used for a long time, even if it is capped, the Print Head too, may become dried or clogged if the printer has not been used for a long time.

We recommend the printer to be used at least once a month.

Note

- Depending on the type of paper, ink may blur if you trace the printed area with a highlight pen or paint-stick, or bleed if water or sweat comes in contact with the printed area.

■ Does the printer need to be handled with care when using or transporting?

● Tip!: Do not use or transport the printer vertically or slanted!

If the printer is used or transported vertically or slanted, the printer may become damaged or ink may leak from the printer.

Be sure not to use or transport the printer vertically or slanted.

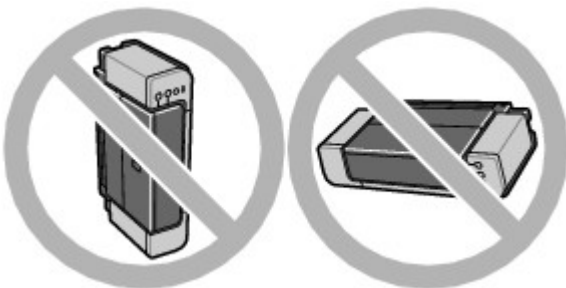

● Tip!: Do not place any object on the Top Cover!

Do not place any object on the Top Cover. It will fall into the Rear Tray when the Top Cover is opened and cause the printer to malfunction.

Also, place the printer where objects will not fall on it.

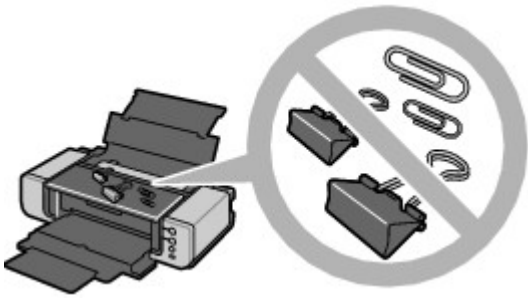

■ Lamp on the printer is flashing: What can I do?

● Alarm lamp is flashing orange.

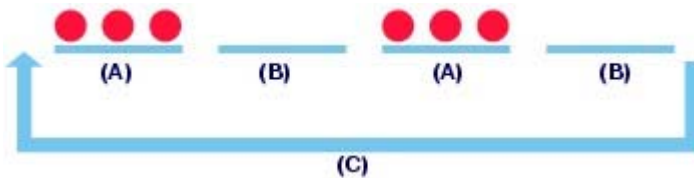

(A) **Alarm** lamp flashes

(B) **Alarm** lamp is off

(C) **Alarm** lamp flashes repeatedly

Your printer has an error.

Refer to "[Troubleshooting](#)" in the on-screen manual: *Advanced Guide*, then resolve the error.

● Power lamp flashes green once and Alarm lamp flashes orange once alternately.

An error that requires repair has occurred. Contact the service center.

■ Colors are uneven, and print results are blurred.

● Tip!: Print the nozzle check pattern to check if the nozzles are clogged.

If the print head nozzles are clogged, colors may become uneven or the print results may be blurred.



In this case



Print the nozzle check pattern

Check the printed check pattern to see if the nozzles are clogged.

See [When Printing Becomes Faint or Colors Are Incorrect](#).

■ How can I adjust color tones of the photos to print?

You can make detailed settings to adjust colors with Easy-PhotoPrint Pro or the printer driver.

For details, refer to the on-screen manual: [Advanced Guide](#).

- Adjust the intensity of each color, Cyan, Magenta, and Yellow, in the color balance setting.



Default



Color correction applied

- Select the cool tone or warm tone in grayscale printing.



Cool tone



Default



Warm tone

- Print images using the ICC profile specified in the software application.



Adobe RGB



sRGB





Basic Guide 

Printing

Troubleshooting

How to Use This Manual

Printing This Manual

Printing on DVD/CDs

Maintenance

Changing the Printer Settings

Appendix

When you display this on-screen manual in a language environment other than English, some English descriptions may be displayed.

Printing

Printing from a Computer

Printing with the Bundled Application Software

What Is Easy-PhotoPrint EX?

Printing Photos

Starting Easy-PhotoPrint EX

Selecting a Photo

Selecting the Paper

Printing

Creating an Album

Starting Easy-PhotoPrint EX

Selecting the Paper and Layout

Selecting a Photo

Editing

Printing

Printing a DVD/CD

Printing Calendars

Starting Easy-PhotoPrint EX

Selecting the Paper and Layout

Selecting a Photo

Editing

Printing

Printing Stickers

Starting Easy-PhotoPrint EX

Selecting the Paper and Layout

Selecting a Photo

Editing

Printing

Printing Layout

Starting Easy-PhotoPrint EX

Selecting the Paper and Layout

Selecting a Photo

Editing

Printing

Correcting and Enhancing Photos

Using the Auto Photo Fix Function

Using the Red-Eye Correction Function

Using the Face Brightener Function

Using the Face Sharpener Function

Using the Digital Face Smoothing Function

Using the Blemish Remover Function

Adjusting Images

Correct/Enhance Images Window

Questions and Answers

How Can I Move (or Copy) the Saved File?

Which Side of the Displayed Image Does the Printing Start from?

How Do I Print with Even Margins?

What Is "C1" or "C4"?

Photo Print Settings

Printing on a DVD/CD

Printing Photos in Grayscale

Printing Vivid Photos

Reducing Photo Noise

Cropping Photos (Photo Print)

Printing Dates on Photos (Photo Print)

Printing Multiple Photos on One Page

Printing an Index

Printing ID Photos (ID Photo Print)

Printing Photo Information

Saving Photos

Opening Saved Files

Other Settings

Changing Layout

Changing Background

Adding Photos

Swapping Positions of Photos

Replacing Photos

Changing Position, Angle and Size of Photos

Cropping Photos

Framing Photos

Printing Dates on Photos

Attaching Comments to Photos

Adding Text to Photos

Saving

Setting Holidays

Setting Calendar Display

Opening Saved Files

What Is Easy-PhotoPrint Pro?

Printing Beautiful Photos

Printing with ICC Profiles (Adobe RGB, sRGB)

Printing Edited/Retouched sRGB Images

Printing with Canon's Unique Color Tones

Printing According to the Lighting in the Viewing Environment

Printing with Easy-PhotoPrint Pro

Starting Easy-PhotoPrint Pro

Selecting a Photo

Selecting the Paper and Layout

Printing

Adjust the Colors of Photo

- Printing Photos in Grayscale

- Adjusting the Color Balance

- Adjusting Color Balance Using Sample Patterns

- Adjusting Brightness/Contrast

- Adjusting Brightness/Contrast Using Sample Patterns

Easy-PhotoPrint Pro Settings

- Printing Borderless Photos

- Printing an Index

- Printing Contact Sheets

- Printing Advanced Information

- Trimming Photos

- Printing with Adjusted Print Size

- Saving Print Settings

Printing with Other Application Software

Various Printing Methods

- Printing with Easy Setup

- Setting a Page Size and Orientation

- Setting the Number of Copies and Printing Order

- Setting the Stapling Margin

- Borderless Printing

- Fit-to-Page Printing

- Scaled Printing

- Page Layout Printing

- Poster Printing

- Booklet Printing

- Duplex Printing

- Stamp/Background Printing

- Saving a Stamp Setting

- Saving Image Data to be Used as a Background

- Printing an Envelope

- Front Feed Printing

- Displaying the Print Results before Printing

- Setting Paper Dimensions (Custom Size)

Changing the Print Quality and Correcting Image Data

- Selecting a Combination of the Print Quality Level and a Halftoning Method

- Printing a Color Document in Monochrome

- Adjusting Tone

- Specifying Color Correction

- Optimal Photo Printing of Image Data

- Adjusting Colors with the Printer Driver

- Printing with ICC Profiles

- Adjusting Color Balance

- Adjusting Brightness

- Adjusting Intensity

- Adjusting Contrast

- Simulating an Illustration

- Representing Image Data with a Single Color

- Presenting Image Data with Vivid Colors
- Smoothing Jagged Outlines
- Changing Color Properties to Improve Coloration
- Reducing Photo Noise
- Overview of the Printer Driver
- Printer Driver Operations
- Canon IJ Printer Driver
- How to Open the Printer Driver Setup Window
- Maintenance Tab
- Canon IJ Status Monitor
- The Canon IJ Preview

Printing Photographs Directly from a Compliant Device

- Printing Photographs Directly from a Compliant Device
 - Printing Photographs Directly from a Compliant Device
 - About PictBridge Print Settings
 - Settings on a PictBridge Compliant Device

Troubleshooting

Troubleshooting

- If an Error Occurs
 - The Printer Cannot Be Powered On
 - Alarm Lamp Flashes Orange
 - Power Lamp Flashes Green and Alarm Lamp Flashes Orange Alternately
 - Cannot Install the Printer Driver
 - Cannot Install the Application Program
 - Easy-PhotoPrint Pro Does Not Start up or Easy-PhotoPrint Pro Menu Does Not Appear
 - Cannot Connect to Computer Properly
 - Printing Speed Is Slow / Hi-Speed USB Connection Does Not Work/"This device can perform faster" Message Is Displayed
 - Print Results Not Satisfactory
 - Cannot Print to End of Job
 - No Printing Results/Printing Is Blurred/Colors Are Wrong/White Streaks
 - Lines Are Misaligned
 - Printed Paper Curls or Has Ink Blots
 - Paper Is Smudged/Printed Surface Is Scratched
 - Back of the Paper Is Smudged
 - Colors Are Uneven or Streaked
 - Printing Does Not Start
 - Printing Stops Before It Is Completed
 - Printer Moves But Ink Is Not Ejected
 - Printing Speed Is Not as Fast as Expected
 - Print Head Holder Does Not Move to the Position for Replacing
 - Paper Does Not Feed Properly
 - Paper Does Not Feed from the Paper Source Specified in the Printer Driver
 - Paper Jams

Message Appears on the Computer Screen

Error Number: B200 A printer error has occurred. Turn the printer off and unplug the power cord of the printer from the power supply. Then contact the service center. Is Displayed

Error Number: **** A printer error has occurred. Turn the printer off and then on again. If this doesn't clear the error, see the user's guide for more detail. Is Displayed

Error Regarding the Rear Tray or Front Tray Is Displayed

Error Regarding the Width of Paper Is Displayed

Error Regarding Automatic Print Head Alignment Is Displayed

Writing Error/Output Error/Communication Error

Error Number: 92 Is Displayed

Error Number: 93 Is Displayed

Error Number: 300 Is Displayed

Error Number: 1281 Is Displayed

Error Number: 1283 Is Displayed

Error Number: 1284 Is Displayed

Error Number: 1320 Is Displayed

Error Number: 1321 Is Displayed

Error Number: 1700 Is Displayed

Ink Info Number: 1600 Is Displayed

Ink Info Number: 1683 Is Displayed

Ink Info Number: 1688 Is Displayed

Error Number: 1851 Is Displayed

Error Number: 1856 Is Displayed

Error Number: 2001 Is Displayed

Error Number: 2002 Is Displayed

Error Number: 2500 Is Displayed

Other Error Messages

The Inkjet Printer/Scanner/Fax Extended Survey Program Screen Is Displayed

The Inkjet Printer/Scanner/Fax Extended Survey Program Icon Appears

For Windows Users

Printer Status Monitor Is Not Displayed

Error Message Appears on a PictBridge Compliant Device

FAQs

If You Cannot Resolve the Problem

Instructions for Use (Printer Driver)

Using Easy-PhotoPrint EX

About Solution Menu

Advanced Guide

Advanced Guide > How to Use This Manual

How to Use This Manual

- ➔ [Operating the Contents Pane](#)
- ➔ [Operating the Explanation Window](#)
- ➔ [Printing This Manual](#)
- ➔ [Using Keywords to Find a Topic](#)
- ➔ [Registering Topics to My Manual](#)
- ➔ [Symbols Used in This Document](#)
- ➔ [Trademarks](#)

[Page top](#) ↑

Advanced Guide

Advanced Guide > How to Use This Manual > Operating the Contents Pane

Operating the Contents Pane

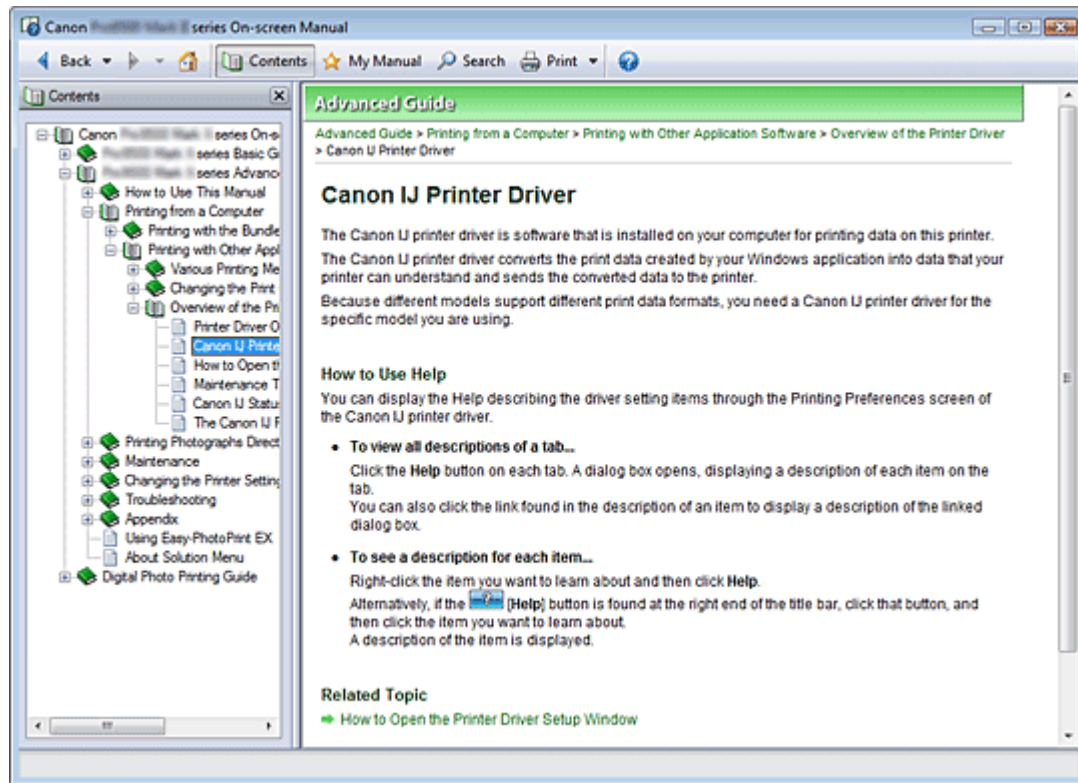

When you click a title displayed in the Contents pane found to the left of the on-screen manual, the pages of that title are displayed in the explanation window on the right side.

When you click  found to the left of , the titles found in the lower hierarchies are displayed.

Note

- Click  to close or display the Contents pane.

Advanced Guide

Advanced Guide > How to Use This Manual > Operating the Explanation Window

Operating the Explanation Window

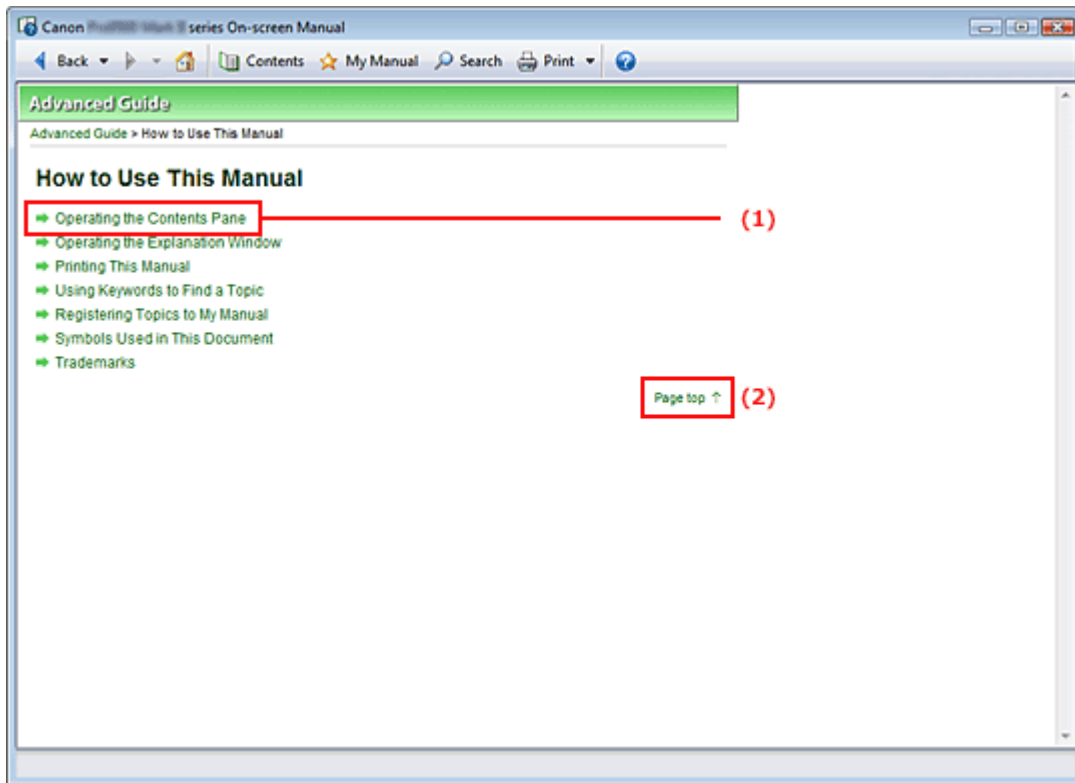

(1) Click the green characters to jump to the corresponding page.

(2) The cursor jumps to the top of this page.

Page top ↑

Advanced Guide

Advanced Guide > How to Use This Manual > Printing This Manual

Printing This Manual

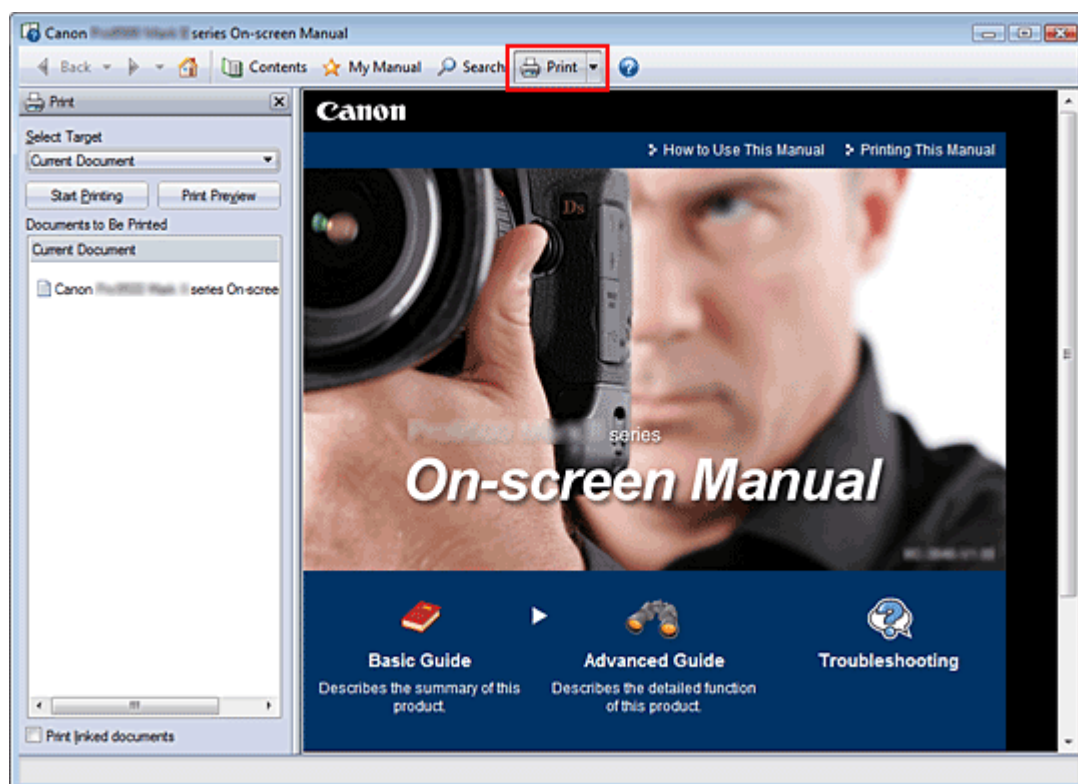



Click  to display the Print pane to the left of the on-screen manual.

Important

- When printing on plain paper, open the printer driver setup window, click the Quick Setup tab, and select Plain Paper for Media Type.
- To open the printer driver setup window, click , click Print Settings to open the Print dialog box, and then click Properties....

Note

- Click  to close or display the Print pane.
- Click , and then click Option Settings to display the Option Settings dialog box. You can then set up the printing operation.
 - Print document title and page number

When this check box is checked, the manual name and the page number are printed in the header (top of the document).
 - Print background color and images

When this check box is checked, the background color and the image are printed. Some images are printed regardless of whether this check box is checked or not.
 - Check number of pages to be printed before printing

When this check box is checked, the Print Page Count Confirmation dialog box is displayed before printing starts. This dialog box allows you to check how many pages will be printed.
- Click , and then click Print Settings to display the Print dialog box. When the dialog box is displayed, select the printer to be used for printing. After selecting the printer to be used, click Properties... to specify the print settings.

The following four methods of printing are available:

- [Current Document](#)
- [Selected Documents](#)
- [My Manual](#)
- [All Documents](#)

Current Document

You can print the currently displayed topic.

1. From Select Target, select Current Document

The title of the currently displayed topic is displayed in the Documents to Be Printed list.

Note

- By selecting Print linked documents, you can also print documents that are linked to the current document. The linked documents are added to the Documents to Be Printed list.
 - Click Print Preview to display and check what the print results will look like before you actually print the document.
-

2. Click Start Printing

The Print Page Count Confirmation dialog box is displayed.

3. Execute print

Confirm the number of pages to be printed, and then click Yes.

The topics that are currently displayed are printed.

Selected Documents

You can select and print the topics that you want printed.

1. From Select Target, select Selected Documents

The titles of all topics are displayed in the Documents to Be Printed list.

2. Select the topics to be printed

From the Documents to Be Printed list, select the title check boxes of the topics to be printed.

Note

- When you select the Automatically select documents in lower hierarchies check box, the check boxes of all titles found in the lower hierarchies are selected.
 - Click Select All to select the check boxes of all titles.
Click Clear All to clear the check boxes of all titles.
 - Click Print Preview to display and check what the print results will look like before you actually print the document.
-

3. Click Start Printing

The Print Page Count Confirmation dialog box is displayed.

4. Execute print

Confirm the number of pages to be printed, and then click Yes.

All topics with selected check boxes are printed.

My Manual

You can select and print topics registered in My Manual.

For details about My Manual, see "[Registering Topics to My Manual](#)."

1. From Select Target, select My Manual

The titles of the topics that have been registered to My Manual are displayed in the Documents to Be Printed list.

2. Select the topics to be printed

From the Documents to Be Printed list, select the title check boxes of the topics to be printed.

Note

- Click Select All to select the check boxes of all titles.
Click Clear All to clear the check boxes of all titles.
 - Click Print Preview to display and check what the print results will look like before you actually print the document.
-

3. Click Start Printing

The Print Page Count Confirmation dialog box is displayed.

4. Execute print

Confirm the number of pages to be printed, and then click Yes.

All topics with selected check boxes are printed.

All Documents

You can print all topics of the on-screen manual.

1. From Select Target, select All Documents

The titles of all topics are displayed in the Documents to Be Printed list, and the check boxes are automatically selected.

Note

- If you clear the check box of a topic, that topic is not printed.
 - Click Select All to select the check boxes of all titles.
Click Clear All to clear the check boxes of all titles.
 - Click Print Preview to display and check what the print results will look like before you actually print the document.
-

2. Click Start Printing

The Print Page Count Confirmation dialog box is displayed.

3. Execute print

Confirm the number of pages to be printed, and then click Yes.

All topics are printed.

Important

- A large amount of paper is necessary to print all topics. Before printing, be sure to check the number of print pages displayed in the Print Page Count Confirmation dialog box.
- The Print Preview dialog box allows you to scale the printing to the paper width or to set the zoom rate. However, if the print data extends outside the paper because of the new zoom rate, that portion of the document will not be printed on the paper.

Advanced Guide

Advanced Guide > How to Use This Manual > Using Keywords to Find a Topic

Using Keywords to Find a Topic

You can enter a keyword to search for a target page.

All installed on-screen manuals (user's guides) are searched.

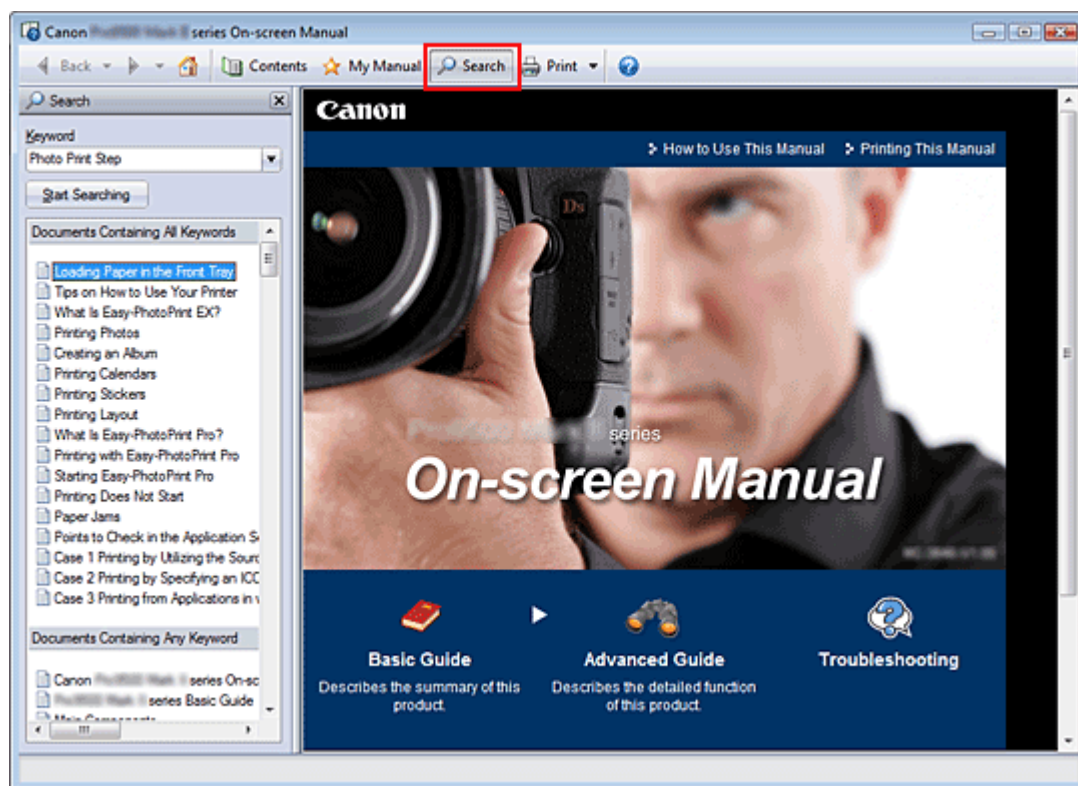

1. Click

The Search pane is displayed to the left of the on-screen manual.

Note

- Click  to close or display the Search pane.

2. Enter a keyword

In Keyword, enter a keyword for the item to be checked.

If you want to enter multiple keywords, insert a space between the keywords.

Note

- You can enter up to 10 keywords or up to 255 characters.
- Uppercase and lowercase are not discriminated.
- The program can also search for keywords that contain spaces.

3. Click Start Searching

The search is started, and the titles of topics containing the keyword are displayed in the search results list.

When you execute a search by entering multiple keywords, the search results are displayed as shown below.

[Documents Containing Perfect Match]

Topics containing the entire search character string (including spaces) exactly as entered (perfect match)

[Documents Containing All Keywords]

Topics containing all keywords that were entered

[Documents Containing Any Keyword]

Topics containing at least one of the keywords that were entered

4. Display the topic that you want to read

From the search results list, double-click (or select and press Enter) the title of the topic you want to read.

When the pages of that title are displayed, the keywords found on those pages are highlighted.

[Page top ↕](#)

Advanced Guide

Advanced Guide > How to Use This Manual > Registering Topics to My Manual

Registering Topics to My Manual

Register frequently read pages as My Manual topics so that you can refer to those pages easily at any time.

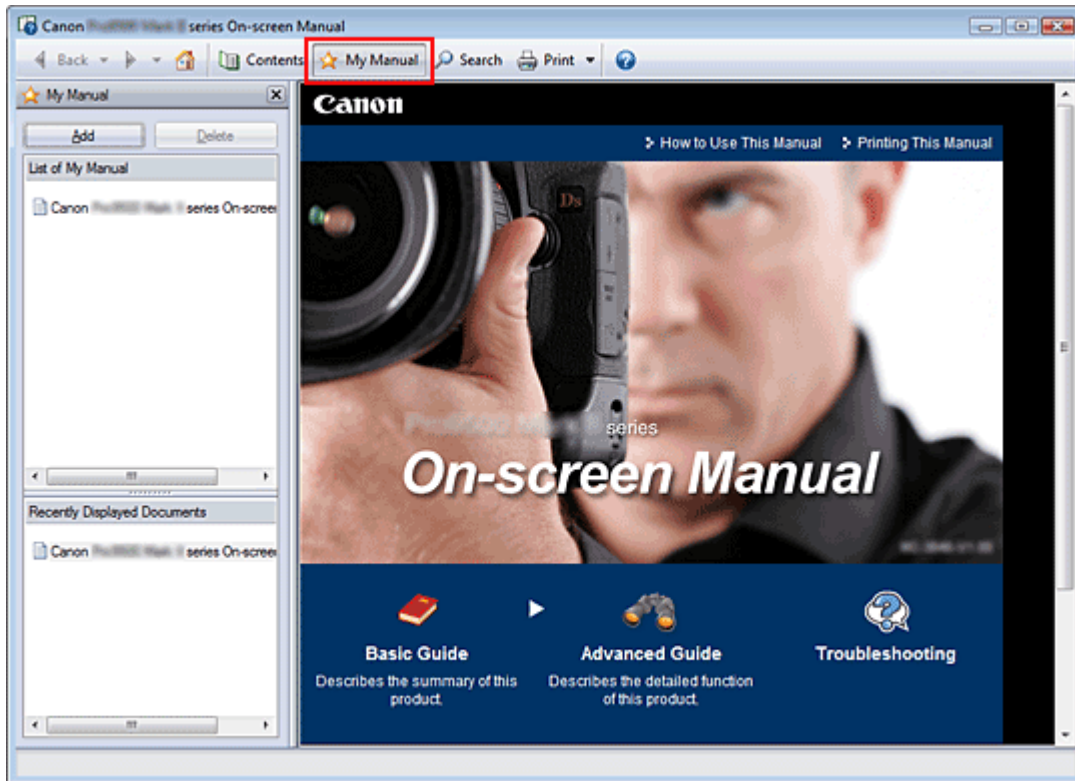

1. Display the topic

Display the topic to be added to My Manual.

2. Click My Manual

The My Manual pane is displayed to the left of the on-screen manual.

Note

- Click  My Manual to close or display the My Manual pane.

3. Register the topic to My Manual

Click Add.

The currently displayed topic is added to List of My Manual.

Note

- Alternatively, from the Recently Displayed Documents list, double-click (or select and press Enter) the topic to be added to My Manual to display that topic, and then click Add.

4. Display My Manual

When you double-click (or select and press Enter) a topic displayed in List of My Manual, that topic is displayed in the Explanation window.

Note

- To delete a topic from List of My Manual, select that topic from the list, and then click Delete (or press Delete).

Advanced Guide

[Advanced Guide](#) > [How to Use This Manual](#) > [Symbols Used in This Document](#)

Symbols Used in This Document

Warning

Instructions that, if ignored, could result in death or serious personal injury caused by incorrect operation of the equipment. These must be observed for safe operation.

Caution

Instructions that, if ignored, could result in personal injury or material damage caused by incorrect operation of the equipment. These must be observed for safe operation.

Important

Instructions that must be observed for safe operation.

Note

Instructions as notes for operation or additional explanations.

Windows

Indicates operations in Windows.

Macintosh

Indicates operations in Macintosh.

[Page top](#) 

Advanced Guide

[Advanced Guide](#) > [How to Use This Manual](#) > [Trademarks](#)

Trademarks

- Microsoft is a registered trademark of Microsoft Corporation.
- Windows is a trademark or registered trademark of Microsoft Corporation in the U.S. and/or other countries.
- Windows Vista is a trademark or registered trademark of Microsoft Corporation in the U.S. and/or other countries.
- Macintosh and Mac are trademarks of Apple Inc., registered in the U.S. and other countries.
- Adobe, Adobe Photoshop, Adobe RGB and Adobe RGB (1998) are either registered trademarks or trademarks of Adobe Systems Incorporated in the United States and or other countries.
- Bluetooth is a trademark of Bluetooth SIG, Inc., U.S.A. and licensed to Canon Inc.

Exif Print

This machine supports Exif Print.

Exif Print is a standard for enhancing the communication between digital cameras and printers. By connecting to an Exif Print-compliant digital camera, the camera's image data at the time of shooting is used and optimized, yielding extremely high quality prints.

[Page top](#) ↕

Advanced Guide

Advanced Guide > Printing from a Computer

Printing from a Computer

- ➔ [Printing with the Bundled Application Software](#)
- ➔ [Printing with Other Application Software](#)

[Page top](#) ↑

Advanced Guide

Advanced Guide > Printing from a Computer > Printing with the Bundled Application Software

Printing with the Bundled Application Software

- ➔ [What Is Easy-PhotoPrint EX?](#)
- ➔ [Printing Photos](#)
- ➔ [Creating an Album](#)
- ➔ [Printing a DVD/CD](#)
- ➔ [Printing Calendars](#)
- ➔ [Printing Stickers](#)
- ➔ [Printing Layout](#)
- ➔ [Correcting and Enhancing Photos](#)
- ➔ [Questions and Answers](#)
- ➔ [Photo Print Settings](#)
- ➔ [Other Settings](#)
- ➔ [What Is Easy-PhotoPrint Pro?](#)
- ➔ [Printing Beautiful Photos](#)
- ➔ [Printing with Easy-PhotoPrint Pro](#)
- ➔ [Adjust the Colors of Photo](#)
- ➔ [Easy-PhotoPrint Pro Settings](#)

[Page top](#) ↑

Advanced Guide

Advanced Guide > Printing from a Computer > Printing with the Bundled Application Software > What Is Easy-PhotoPrint EX?

Easy-PhotoPrint EX

What Is Easy-PhotoPrint EX?

Easy-PhotoPrint EX allows you to create albums, calendars and stickers easily using photos taken with digital cameras.

You can also print borderless photos easily.

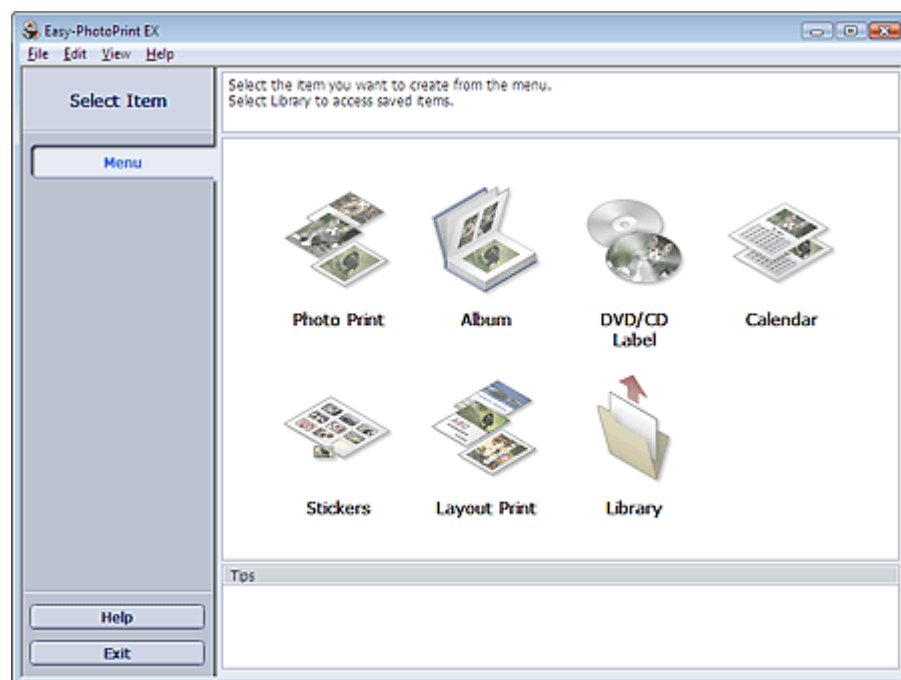

Important

- Easy-PhotoPrint EX does not support Windows 95, Windows 98, Windows Me, or Windows NT4.
- Easy-PhotoPrint EX can only be used with Canon inkjet printers. It does not support some printers, including Canon compact printers (SELPHY CP series).
- If a printer that supports Easy-PhotoPrint EX is not installed, you cannot print items you create.
- If Easy-PhotoPrint EX is installed on a computer that already has Easy-LayoutPrint installed, Easy-LayoutPrint will be replaced by Easy-PhotoPrint EX.

Note

- Printing on paper larger than A4 is available with supported printers only. See your printer manual for details.
- See Help of Easy-PhotoPrint EX for descriptions of Easy-PhotoPrint EX screens. Click Help in a screen or dialog box, or select Easy-PhotoPrint EX Help from the Help menu. Help appears.

About Exif Print

Easy-PhotoPrint EX supports "Exif Print." Exif Print is a standard for enhancing the communication between digital cameras and printers.

By connecting to an Exif Print-compliant digital camera, the image data at the time of shooting is used and optimized, yielding extremely high quality prints.

Starting Easy-PhotoPrint EX from Other Applications

Easy-PhotoPrint EX can be started from other applications.

See the application's manual for details on the procedure for starting.

The Photo Print function is available with the following applications:

- MP Navigator EX Ver.1.00 or later
- ZoomBrowser EX Ver.6.0 or later
- Digital Photo Professional Ver.3.2 or later

Important

- Easy-PhotoPrint EX is subject to the following restrictions when started from Digital Photo Professional:
 - Menu does not appear in the step button area on the left side of the screen.
 - Images cannot be corrected/enhanced.
 - Image display order cannot be changed.
 - Edited images cannot be saved.
 - Options other than Enable ICC Profile cannot be selected for Color correction for printing on the Advanced tab of the Preferences dialog box. Therefore, you cannot use the Vivid Photo and Photo Noise Reduction functions.

The Album function is available with the following applications:

- MP Navigator EX Ver.1.00 or later
- ZoomBrowser EX Ver.5.8 or later

Supported Image File Formats (Extensions)

- BMP (.bmp)
- JPEG (.jpg, .jpeg)
- TIFF (.tif, .tiff)
- PICT (.pict, .pct)
- Easy-PhotoPrint image files (.epp)

Important

- When selecting an image, if there is a TIFF file in the selected folder, the image may not be displayed correctly or Easy-PhotoPrint EX may shut down depending on the TIFF format. In such cases, move the TIFF file to another folder or recreate the file in a different file format, and then select the folder again.

Note

- The thumbnails of files in unsupported formats are displayed as  (Question Mark).
- When Easy-PhotoPrint EX is started from Digital Photo Professional, all image files supported by Digital Photo Professional will be displayed.

File Formats (Extensions) Supported by Easy-PhotoPrint EX

- Easy-PhotoPrint EX Photo Print file (.el6)
- Easy-PhotoPrint EX Album file (.el1)
- Easy-PhotoPrint EX Stickers file (.el2)
- Easy-PhotoPrint EX Calendar file (.el4)
- Easy-PhotoPrint EX Layout file (.el5)
- CD-LabelPrint data (.clid)

Advanced Guide

Advanced Guide > Printing from a Computer > Printing with the Bundled Application Software > Printing Photos

Easy-PhotoPrint EX

Printing Photos

Easy-PhotoPrint EX allows you to print your favorite photos in a variety of layouts.

You can also create borderless photos easily.

Corrections suitable for photos will be applied automatically when printing.

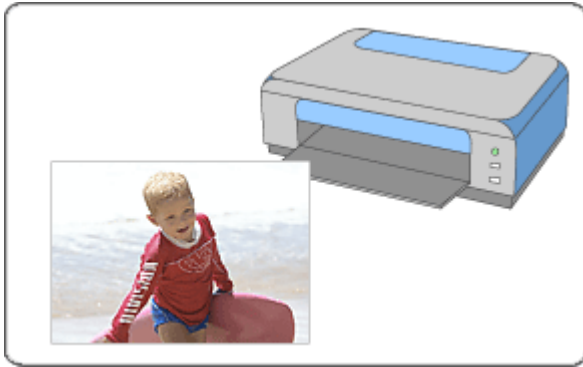

Steps

1. Starting Easy-PhotoPrint EX
2. Selecting a Photo
3. Selecting the Paper
4. Printing

Try This

- ➔ Correcting and Enhancing Photos
- ➔ Printing on a DVD/CD
- ➔ Printing Photos in Grayscale
- ➔ Printing Vivid Photos
- ➔ Reducing Photo Noise
- ➔ Cropping Photos (Photo Print)
- ➔ Printing Dates on Photos (Photo Print)
- ➔ Printing Multiple Photos on One Page
- ➔ Printing an Index
- ➔ Printing ID Photos (ID Photo Print)
- ➔ Printing Photo Information
- ➔ Saving Photos
- ➔ Opening Saved Files

Questions and Answers

- ➔ How Can I Move (or Copy) the Saved File?
- ➔ Which Side of the Displayed Image Does the Printing Start from?
- ➔ How Do I Print with Even Margins?

Advanced Guide

Advanced Guide > Printing from a Computer > Printing with the Bundled Application Software > Printing Photos > Starting Easy-PhotoPrint EX

Easy-PhotoPrint EX



Starting Easy-PhotoPrint EX

1. From the Start menu, select (All) Programs > Canon Utilities > Easy-PhotoPrint EX > Easy-PhotoPrint EX.

Easy-PhotoPrint EX starts and Menu appears.

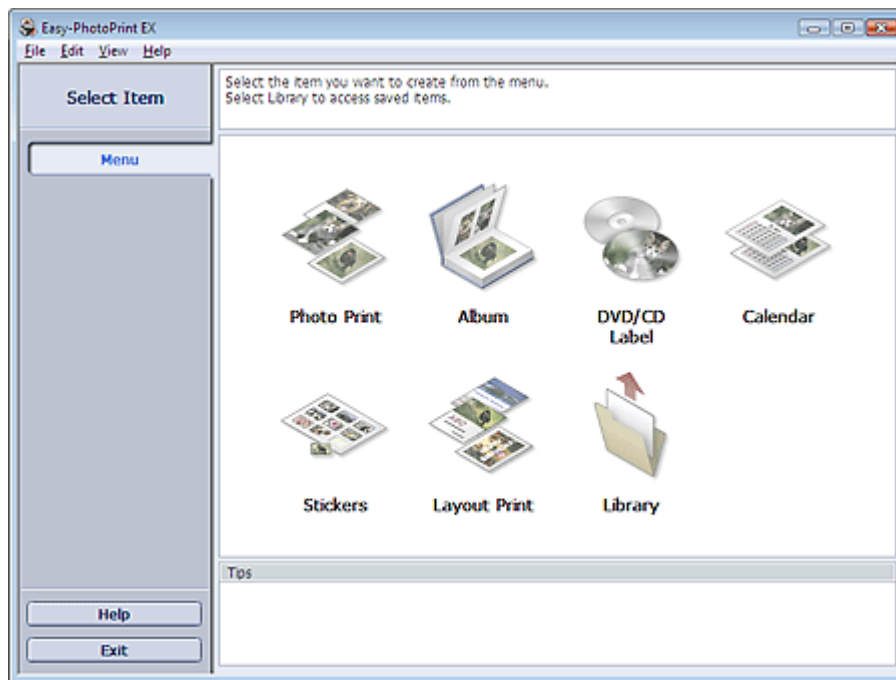

[Page top](#)

Advanced Guide

Advanced Guide > Printing from a Computer > Printing with the Bundled Application Software > Printing Photos > Selecting a Photo

Easy-PhotoPrint EX



Selecting a Photo

1. Click Photo Print from Menu.

The Select Images screen appears.

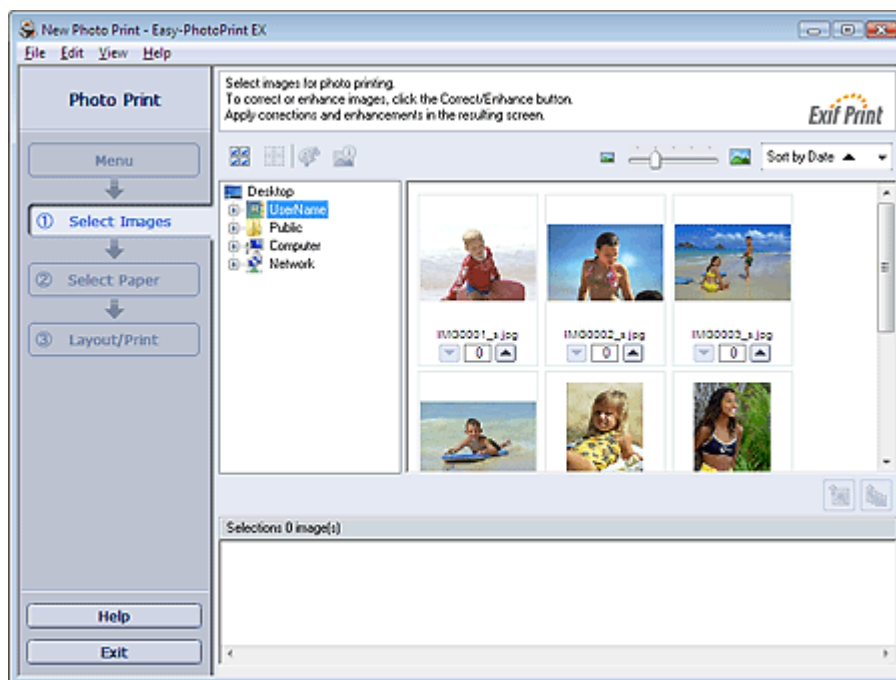

Important

- The thumbnails (reduced images) displayed in the screen may appear as follows:
 - A black line appears along an edge of the image.
 - An edge of the image appears cropped.
 However, such images will be displayed normally when enlarged or previewed, and print results will not be affected.

2. Select the folder that contains the image you want to print from the folder tree area.

The images in the folder will be displayed as thumbnails (miniatures).

Important

- If Easy-PhotoPrint EX is started from another application (MP Navigator EX, ZoomBrowser EX or Digital Photo Professional), the folder tree area will not be displayed. The images opened in the application will be displayed as thumbnails.

3. Click the image you want to print.

The number of copies appears as "1" below the clicked image, while the selected image itself will appear in the selected image area.

Note

- To delete an image in the selected image area, select the image you want to delete and click



(Delete Imported Image).

To delete all images from the selected image area, click



(Delete All Imported Images).

- To print two or more copies of an image, click



(Up arrow) until the number of copies you

want is reached. To reduce the number of copies shown in the box, click  (Down arrow).

- You can change the order of photos using the list located at the top right corner of the screen. You can select the printing order from Sort by Date and Sort by Name.

Note

- You can correct or enhance the selected image before printing.
 - ➔ [Correcting and Enhancing Photos](#)
- See Help for details on the Select Images screen.



[Page top](#) 

Advanced Guide

Advanced Guide > Printing from a Computer > Printing with the Bundled Application Software > Printing Photos > Selecting the Paper

Easy-PhotoPrint EX



Selecting the Paper

1. Click Select Paper.

The Select Paper screen appears.

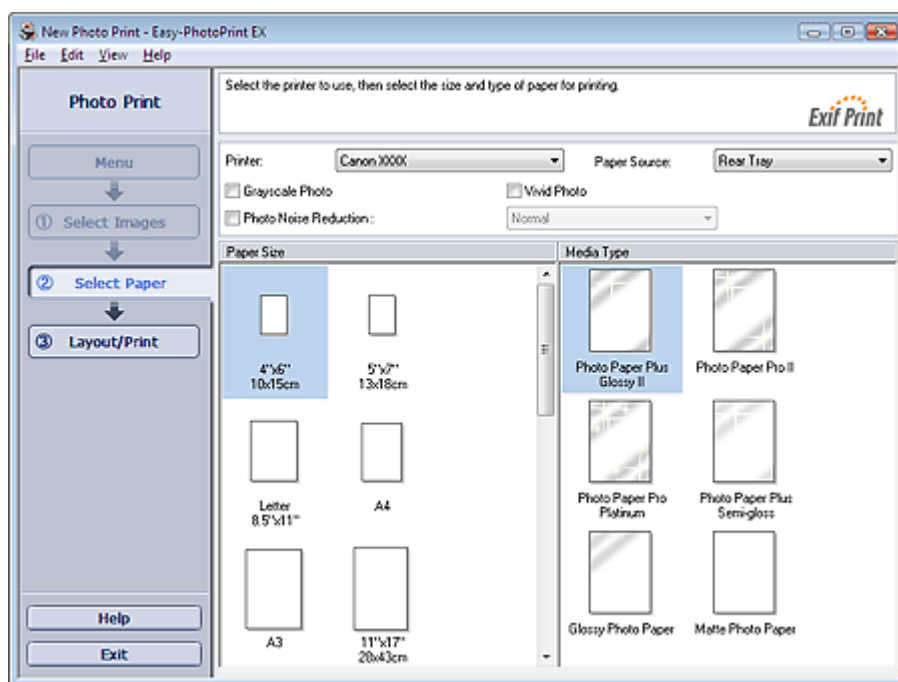

2. Set the following items according to the printer and paper to be used:

Printer

Paper Source

Paper Size

Media Type

Note

- The paper sizes and media types may vary depending on the printer. See Help for details.
- The paper sources may vary depending on the printer and the media type.

Important

- When Fine Art is selected for Paper Size, a 1.38 inch (35 mm) margin is automatically left at the top and bottom of the paper. It is recommended that you check the print range with the image shown in Preview before printing.

Note

- You can print directly on the DVD/CD surface by selecting CD-R for Paper Size.
 - ➔ [Printing on a DVD/CD](#)
- You can print photos in grayscale.
 - ➔ [Printing Photos in Grayscale](#)
- You can print photos with more vivid colors or you can reduce the photo noise.
 - ➔ [Printing Vivid Photos](#)
 - ➔ [Reducing Photo Noise](#)
- See Help for details on the Select Paper screen.



Advanced Guide

Advanced Guide > Printing from a Computer > Printing with the Bundled Application Software > Printing Photos > Printing

Easy-PhotoPrint EX



Printing

1. Click Layout/Print.

The Layout/Print screen appears.

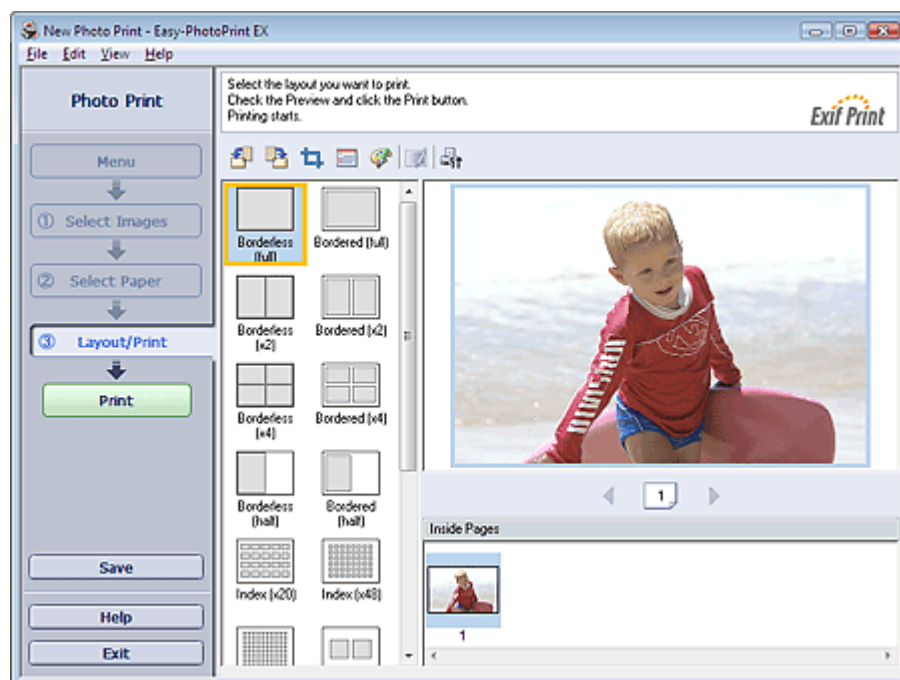

Important

- The thumbnails (reduced images) displayed in the screen may appear as follows:
 - A black line appears along an edge of the image.
 - An edge of the image appears cropped.
 However, such images will be displayed normally when enlarged or previewed, and print results will not be affected.

2. Select a layout you want to use.

Click a borderless layout to print borderless photos.

Note

- The layouts that can be selected may vary depending on the printer, paper size, and media type.

3. Click Print.

Important

- When you print on large size paper such as A3/A3+, some computers cannot print properly if you print more than one page or copy at a time. It is recommended that you print page by page when you print on such paper.
- While printing on paper larger than A4 or printing high-resolution images, data may be printed only to the middle if many images are printed at one time. In such cases, select the Spool print job page by page checkbox in the Preferences dialog box, and then print again.

To display the Preferences dialog box, click  (Settings) or select Preferences... from the File menu.

- When Fine Art is selected for Paper Size, a 1.38 inch (35 mm) margin is automatically left at the top and bottom of the paper. It is recommended that you check the print range with the image shown in Preview before printing.

- White streaks may appear at the top and bottom edges of grayscale photos. In that case, print with a 45 mm (1.77 inch) or more margin at the top and bottom edges.
If you select Bordered (Margin 45) from the layouts, images will be reduced when printing to allow a 45 mm (1.77 inch) margin at the top and bottom edges relative to the printing direction.

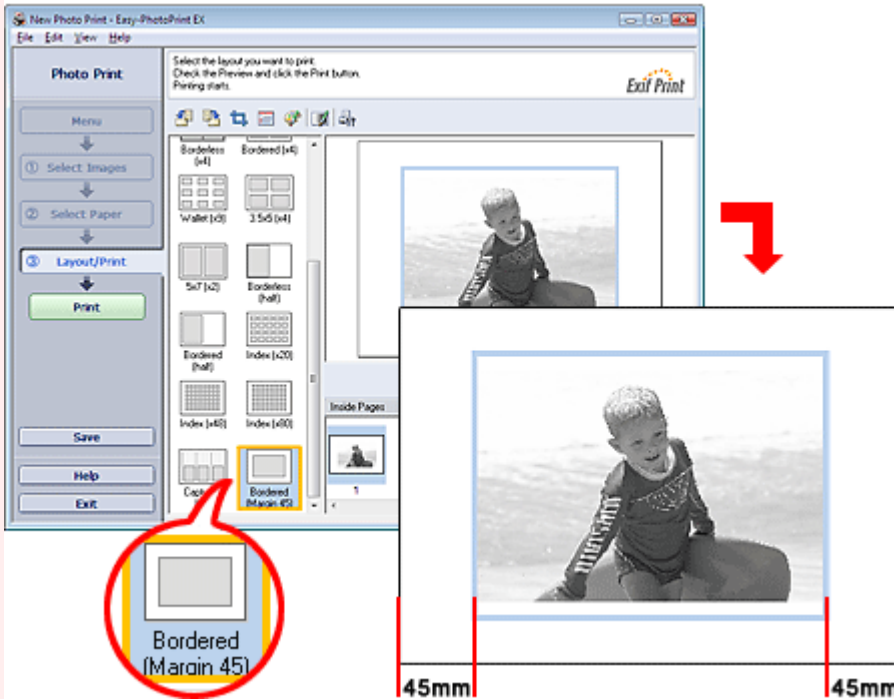

- The photo print settings will be discarded if you exit Easy-PhotoPrint EX without saving the settings. It is recommended that you save the printed image if you want to print it again.

➔ [Saving Photos](#)

- When you print on a bordered layout, the margins on the left and right or the top and bottom may become wider than the other.

➔ [How Do I Print with Even Margins?](#)

Note

- You can crop images or print dates on photos.
 - ➔ [Cropping Photos \(Photo Print\)](#)
 - ➔ [Printing Dates on Photos \(Photo Print\)](#)
- You can correct or enhance the selected image before printing.
 - ➔ [Correcting and Enhancing Photos](#)
- You can print photos in grayscale.
 - ➔ [Printing Photos in Grayscale](#)
- You can specify advanced Photo Print settings (number of copies, print quality, etc.) in the Preferences dialog box.

To display the Preferences dialog box, click  (Settings) or select Preferences... from the File menu.

- See Help for details on the Layout/Print screen.



Advanced Guide

Advanced Guide > Printing from a Computer > Printing with the Bundled Application Software > Creating an Album

Easy-PhotoPrint EX

Creating an Album

Easy-PhotoPrint EX allows you to create your own personalized photo album.

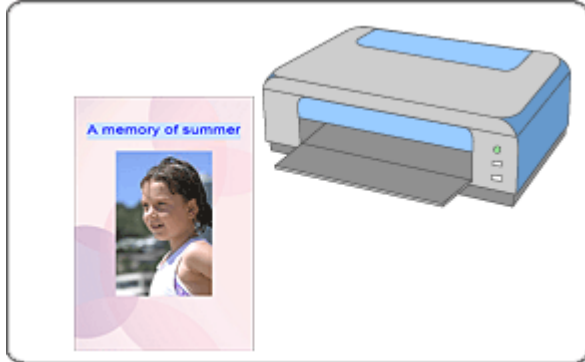

Steps

1. Starting Easy-PhotoPrint EX
2. Selecting the Paper and Layout
3. Selecting a Photo
4. Editing
5. Printing

Try This

- ➔ Correcting and Enhancing Photos
- ➔ Changing Layout
- ➔ Changing Background
- ➔ Adding Photos
- ➔ Swapping Positions of Photos
- ➔ Replacing Photos
- ➔ Changing Position, Angle and Size of Photos
- ➔ Cropping Photos
- ➔ Framing Photos
- ➔ Printing Dates on Photos
- ➔ Attaching Comments to Photos
- ➔ Adding Text to Photos
- ➔ Saving
- ➔ Opening Saved Files

Questions and Answers

- ➔ How Can I Move (or Copy) the Saved File?
- ➔ What Is "C1" or "C4"?

Advanced Guide

Advanced Guide > Printing from a Computer > Printing with the Bundled Application Software > Creating an Album > Starting Easy-PhotoPrint EX

Easy-PhotoPrint EX



Starting Easy-PhotoPrint EX

1. From the Start menu, select (All) Programs > Canon Utilities > Easy-PhotoPrint EX > Easy-PhotoPrint EX.

Easy-PhotoPrint EX starts and Menu appears.

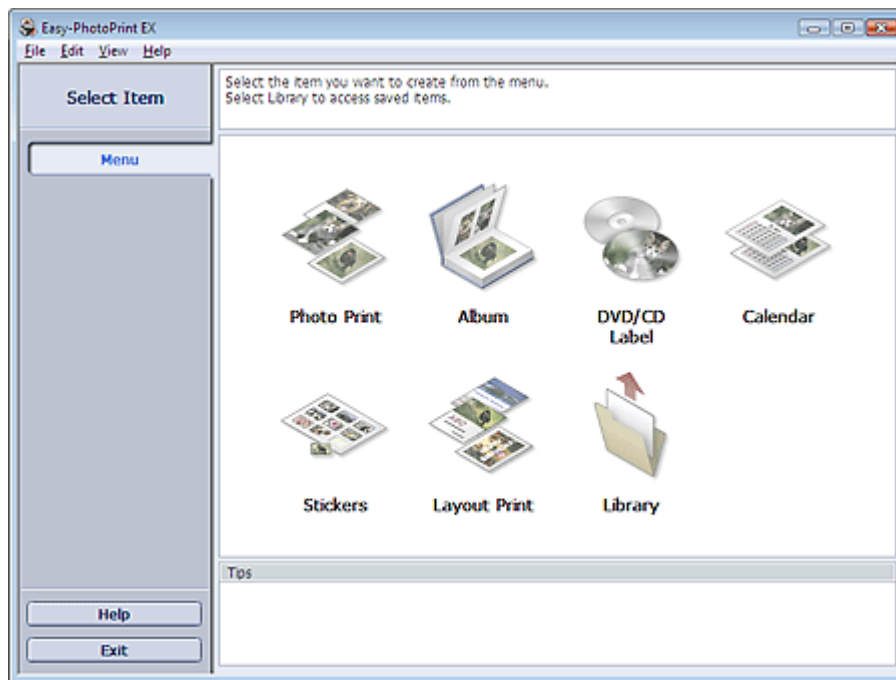

[Page top](#)

Advanced Guide

Advanced Guide > Printing from a Computer > Printing with the Bundled Application Software > Creating an Album > Selecting the Paper and Layout

Easy-PhotoPrint EX



Selecting the Paper and Layout

1. Click Album from Menu.

The Page Setup screen appears.

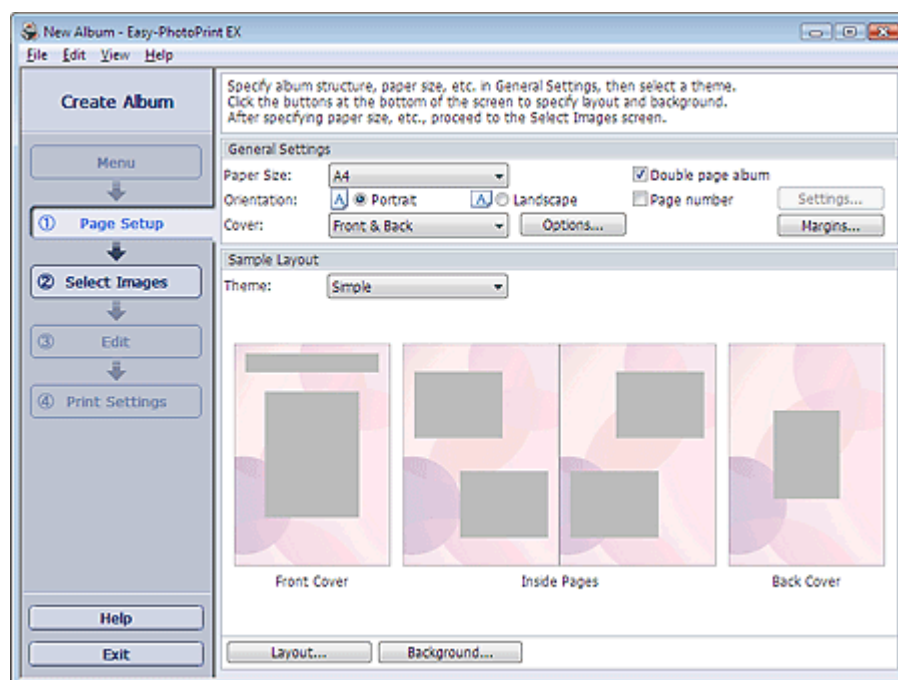

2. Set the following items in the General Settings section:

Paper Size

Orientation

Cover

Double page album

Page number

Note

- See Help on the paper size that can be selected.
- You can select whether to display images on the inside of the front and back covers in the Cover Options dialog box. To display the Cover Options dialog box, select Front or Front & Back for Cover and click Options....
- Select the Double page album checkbox to enable the spread page layout (consisting of two-page master). In a double-page album, you can arrange an image across the left and right pages.
- You can customize the page numbers (position, font size, etc.) in the Page Number Settings dialog box. To display the Page Number Settings dialog box, select the Page number checkbox and click Settings....
- You can customize the margins of the front cover, inside pages and back cover in the Margin Settings dialog box. To display the Margin Settings dialog box, click Margins....

3. Select the theme you want to use from Theme in Sample Layout.

4. If you want to change the layout, click Layout....

The Change Layout dialog box appears.

In the Change Layout dialog box, you can change the layout or select whether to print the date (on

which the picture was taken) on the photo.

Note

- The layouts that can be selected may vary depending on the Paper Size, Orientation, Double page album, or the type of page selected (front cover, inside pages or back cover).
 - You can customize the date (position, size, color, etc.) in the Date Settings dialog box. To display the Date Settings dialog box, select the Print date checkbox in the Change Layout dialog box and click Date Settings....
-

5. If you want to change the background, click Background....

The Change Background dialog box appears.

In the Change Background dialog box, you can paint the background in a single color or paste an image file to it.

Note

- See Help for details on the Page Setup screen.
-



[Page top](#)↑

Advanced Guide

Advanced Guide > Printing from a Computer > Printing with the Bundled Application Software > Creating an Album > Selecting a Photo

Easy-PhotoPrint EX



Selecting a Photo

1. Click Select Images.

The Select Images screen appears.

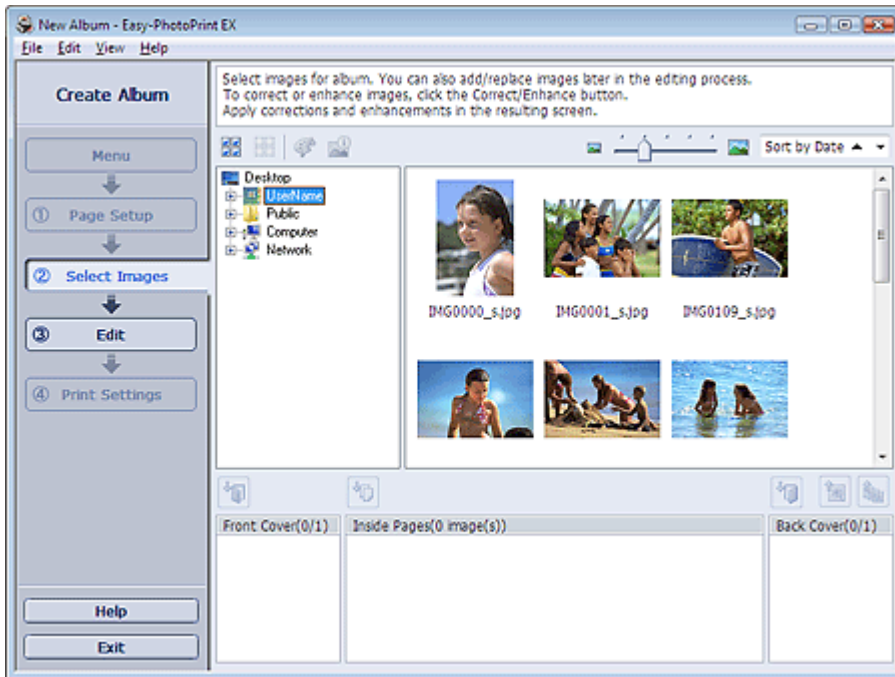

2. Select the folder that contains the image you want to print from the folder tree area.

The images in the folder will be displayed as thumbnails (miniatures).

Important

- If Easy-PhotoPrint EX is started from another application (MP Navigator EX or ZoomBrowser EX), the folder tree area will not be displayed. The images opened in the application will be displayed as thumbnails.

3. Select the image(s) you want to print, and click one of the buttons below.

To print on the front cover, click (Import to Front Cover).

To print on the inside pages, click (Import to Inside Pages).

To print on the back cover, click (Import to Back Cover).

The selected image(s) are displayed in the selected image area.

You can also select the image(s) you want to print by dragging them into the selected image area.

Note

- To delete an image in the selected image area, select the image you want to delete and click

(Delete Imported Image).

To delete all images from the selected image area, click (Delete All Imported Images).

Note

- See Help for details on the Select Images screen.
-



[Page top](#)↑

Advanced Guide

Advanced Guide > Printing from a Computer > Printing with the Bundled Application Software > Creating an Album > Editing

Easy-PhotoPrint EX



Editing

1. Click Edit.

The Edit screen appears.



2. Edit your album if necessary.

- ➔ Changing Layout
- ➔ Changing Background
- ➔ Adding Photos
- ➔ Swapping Positions of Photos
- ➔ Replacing Photos
- ➔ Changing Position, Angle and Size of Photos
- ➔ Cropping Photos
- ➔ Framing Photos
- ➔ Printing Dates on Photos
- ➔ Attaching Comments to Photos
- ➔ Adding Text to Photos

Important

- The edit information will be discarded if you exit Easy-PhotoPrint EX without saving the edited album. It is recommended that you save the item if you want to edit it again.

The page numbers on the front and back covers of the album are displayed as follows:

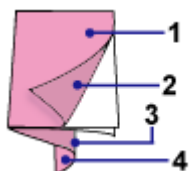

- C1: Front cover
- C2: Inside the front cover
- C3: Inside the back cover
- C4: Back cover

- ➔ Saving

 **Note**

-
- See Help for details on the Edit screen.
-



[Page top](#)

Advanced Guide

Advanced Guide > Printing from a Computer > Printing with the Bundled Application Software > Creating an Album > Printing

Easy-PhotoPrint EX



Printing

1. Click Print Settings.

The Print Settings screen appears.

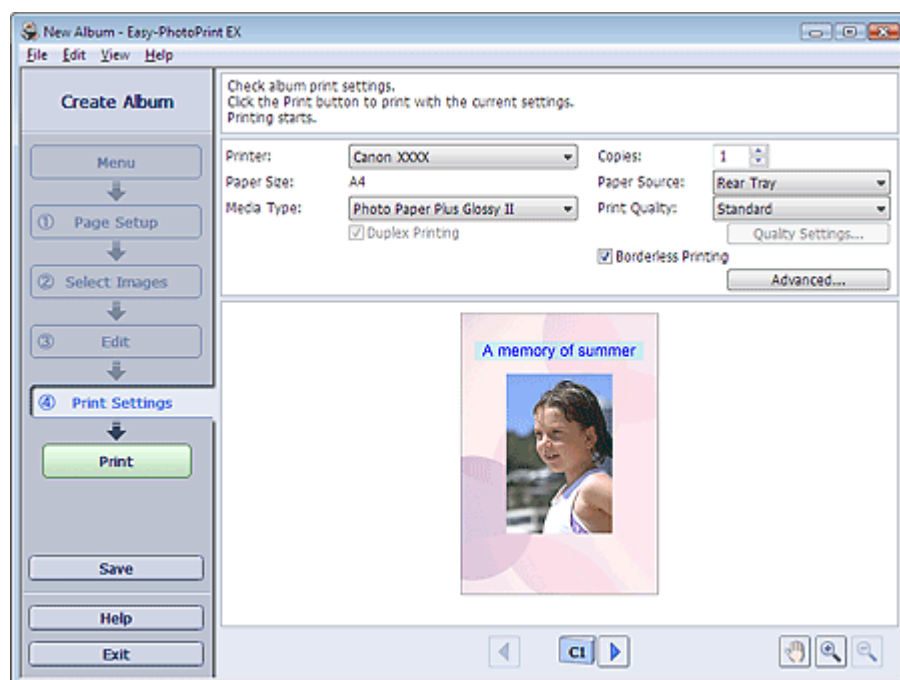

2. Set the following items according to the printer and paper to be used:

Printer

Media Type

Copies

Paper Source

Print Quality

Borderless Printing

Note

- The media types may vary depending on the printer and the paper size.
- Duplex Printing appears if the selected printer and media type support duplex printing. Select this checkbox to print on both sides of the paper.
- Automatic appears if you select the Duplex Printing checkbox after selecting a printer that supports automatic duplex printing and media type that supports duplex printing. Select this checkbox to print on both sides of the paper automatically.
- The paper sources may vary depending on the printer and the media type.
- You can set a custom print quality level in the Print Quality Settings dialog box. To display the Print Quality Settings dialog box, select Custom for Print Quality and click Quality Settings....
- Select the Borderless Printing checkbox to print borderless photos.
- You can specify the print range and the amount of extension for borderless printing in the Print Settings dialog box. To display the Print Settings dialog box, click Advanced....

3. Click Print.

Note

- See Help for details on the Print Settings screen.



[Page top](#)↑

Advanced Guide

Advanced Guide > Printing from a Computer > Printing with the Bundled Application Software > Printing a DVD/CD

Easy-PhotoPrint EX

Printing a DVD/CD

Start Easy-PhotoPrint EX and select DVD/CD Label in Menu to start CD-LabelPrint. CD-LabelPrint allows you to print DVD/CD labels easily.

For details on how to use CD-LabelPrint, install CD-LabelPrint and refer to the application's manual as follows. From the Start menu, select (All) Programs > CD-LabelPrint > Manual.

Important

- DVD/CD Label is not displayed in Menu if CD-LabelPrint is not installed on your computer.

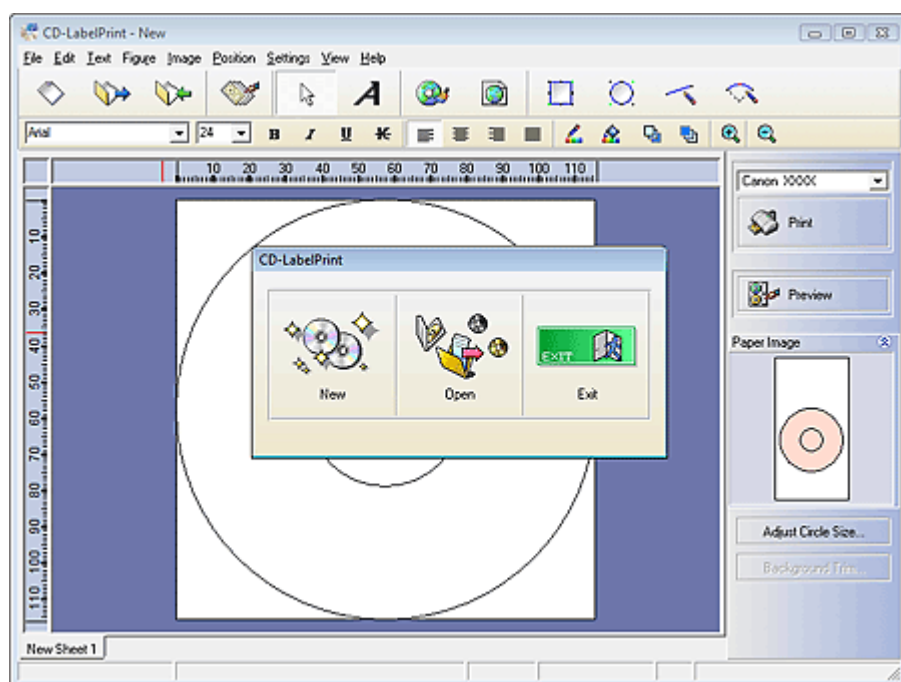

[Page top](#)↑

Advanced Guide

Advanced Guide > Printing from a Computer > Printing with the Bundled Application Software > Printing Calendars

Easy-PhotoPrint EX

Printing Calendars

Easy-PhotoPrint EX allows you to create your own calendar using your favorite photos.

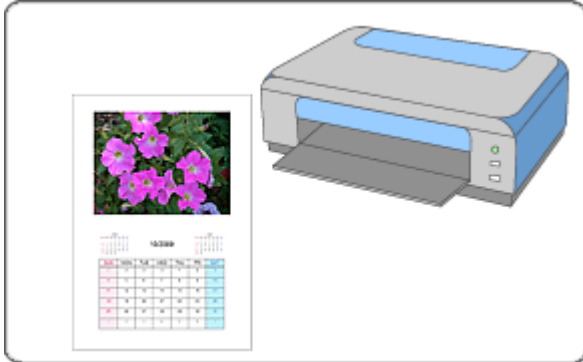

Steps

1. Starting Easy-PhotoPrint EX
2. Selecting the Paper and Layout
3. Selecting a Photo
4. Editing
5. Printing

Try This

- ➔ Correcting and Enhancing Photos
- ➔ Changing Layout
- ➔ Changing Background
- ➔ Adding Photos
- ➔ Swapping Positions of Photos
- ➔ Replacing Photos
- ➔ Changing Position, Angle and Size of Photos
- ➔ Cropping Photos
- ➔ Framing Photos
- ➔ Printing Dates on Photos
- ➔ Adding Text to Photos
- ➔ Setting Calendar Display
- ➔ Setting Holidays
- ➔ Saving
- ➔ Opening Saved Files

Questions and Answers

- ➔ How Can I Move (or Copy) the Saved File?

Advanced Guide

Advanced Guide > Printing from a Computer > Printing with the Bundled Application Software > Printing Calendars > Starting Easy-PhotoPrint EX

Easy-PhotoPrint EX



Starting Easy-PhotoPrint EX

1. From the Start menu, select (All) Programs > Canon Utilities > Easy-PhotoPrint EX > Easy-PhotoPrint EX.

Easy-PhotoPrint EX starts and Menu appears.

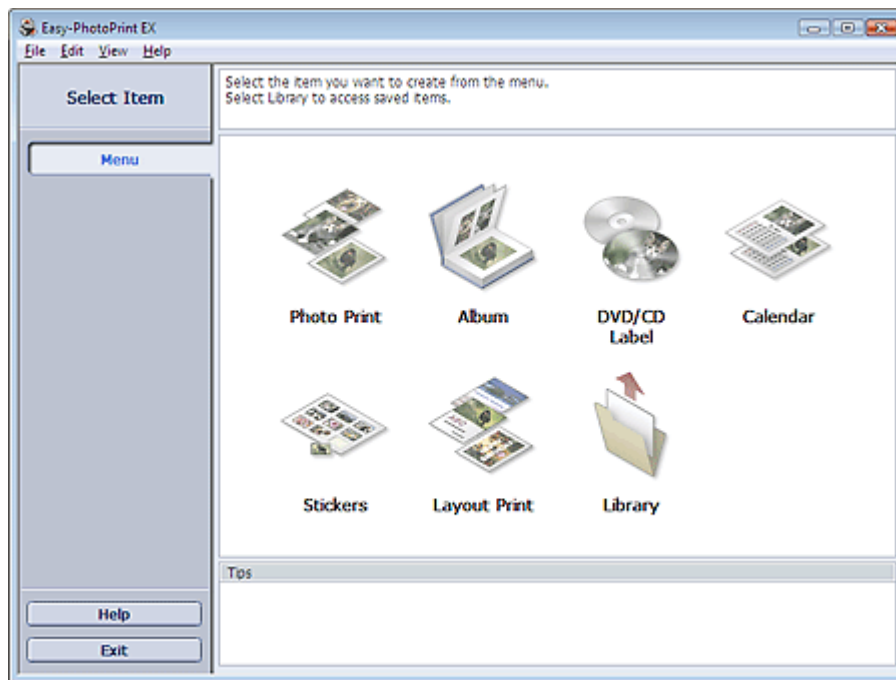

[Page top](#)

Advanced Guide

Advanced Guide > Printing from a Computer > Printing with the Bundled Application Software > Printing Calendars > Selecting the Paper and Layout

Easy-PhotoPrint EX



Selecting the Paper and Layout

1. Click Calendar from Menu.

The Page Setup screen appears.

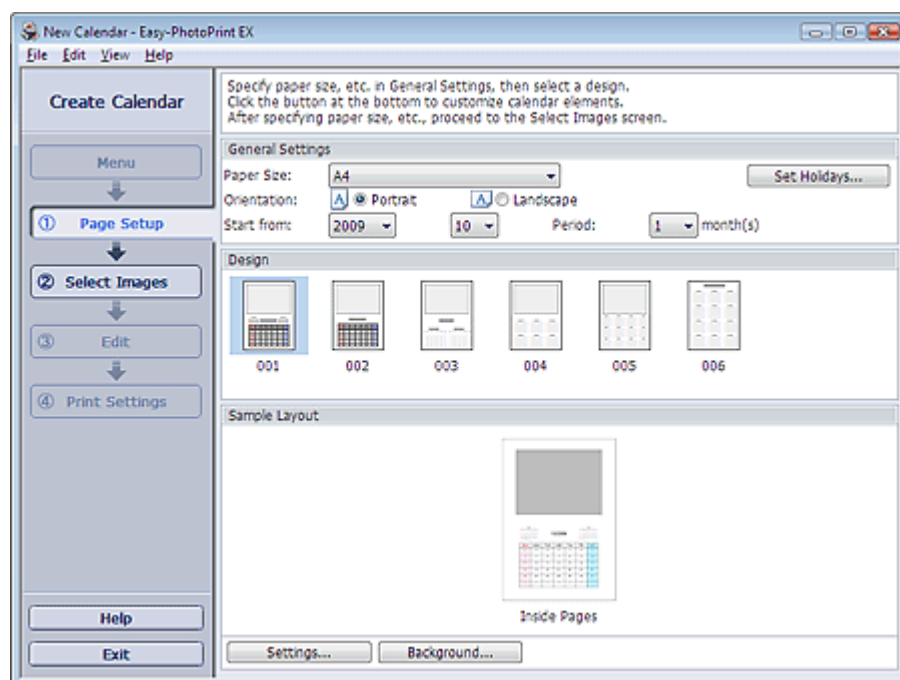

2. Set the following items in the General Settings section:

Paper Size

Orientation

Start from

Period



Note

- See Help on the paper size that can be selected.
- You can add holidays to your calendar.
➔ [Setting Holidays](#)

3. Select a layout for Design.

If necessary, make advanced settings on the calendar and set the background.



Note

- You can customize the calendar display (font colors of the dates and days of the week, position and size of the calendar, etc.).
➔ [Setting Calendar Display](#)
- You can paint the background in a single color or paste an image file to it in the Change Background dialog box. To display the Change Background dialog box, click Background....



Note

- See Help for details on the Page Setup screen.



Advanced Guide

Advanced Guide > Printing from a Computer > Printing with the Bundled Application Software > Printing Calendars > Selecting a Photo

Easy-PhotoPrint EX



Selecting a Photo

1. Click Select Images.

The Select Images screen appears.



2. Select the folder that contains the image you want to print from the folder tree area.

The images in the folder will be displayed as thumbnails (miniatures).

3. Select the image(s) you want to print and click (Import to Inside Pages).

The selected image(s) are displayed in the selected image area.

You can also select the image(s) you want to print by dragging them into the selected image area.

Note

- To delete an image in the selected image area, select the image you want to delete and click



(Delete Imported Image).

To delete all images from the selected image area, click  (Delete All Imported Images).

Note

- See Help for details on the Select Images screen.



Advanced Guide

Advanced Guide > Printing from a Computer > Printing with the Bundled Application Software > Printing Calendars > Editing

Easy-PhotoPrint EX



Editing

1. Click Edit.

The Edit screen appears.

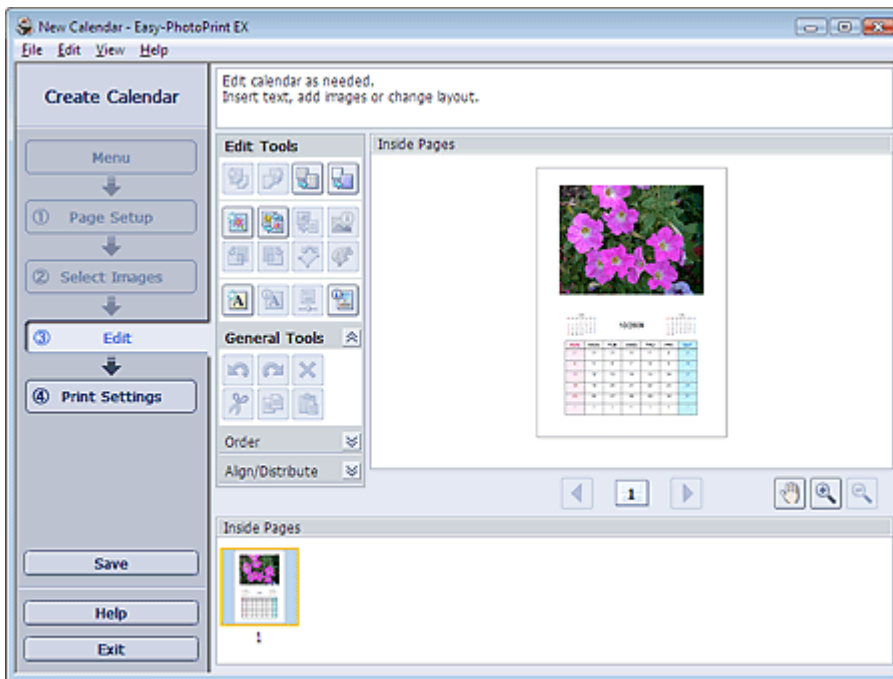

2. Edit the calendar if necessary.

- ➔ Changing Layout
- ➔ Changing Background
- ➔ Adding Photos
- ➔ Swapping Positions of Photos
- ➔ Replacing Photos
- ➔ Changing Position, Angle and Size of Photos
- ➔ Cropping Photos
- ➔ Framing Photos
- ➔ Printing Dates on Photos
- ➔ Adding Text to Photos
- ➔ Setting Calendar Display
- ➔ Setting Holidays

Important

- The edit information will be discarded if you exit Easy-PhotoPrint EX without saving the edited calendar. It is recommended that you save the item if you want to edit it again.
- ➔ Saving

Note

- See Help for details on the Edit screen.



Advanced Guide

Advanced Guide > Printing from a Computer > Printing with the Bundled Application Software > Printing Calendars > Printing

Easy-PhotoPrint EX



Printing

1. Click Print Settings.

The Print Settings screen appears.

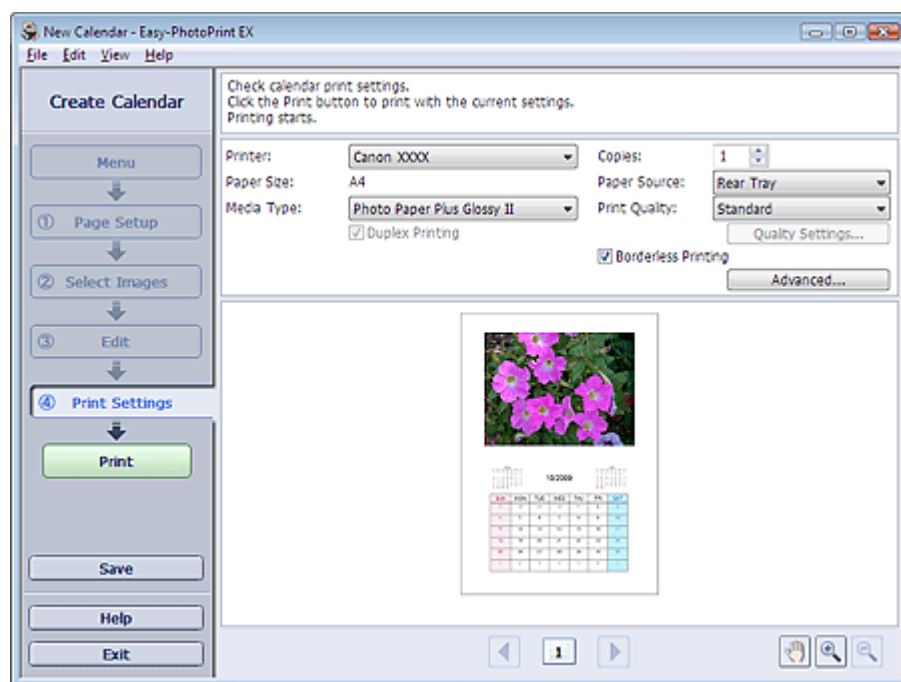

2. Set the following items according to the printer and paper to be used:

Printer

Media Type

Copies

Paper Source

Print Quality

Borderless Printing

Note

- The media types may vary depending on the printer and the paper size.
- Duplex Printing appears if the selected printer and media type support duplex printing. Select this checkbox to print on both sides of the paper.
- Automatic appears if you select the Duplex Printing checkbox after selecting a printer that supports automatic duplex printing and media type that supports duplex printing. Select this checkbox to print on both sides of the paper automatically.
- The paper sources may vary depending on the printer and the media type.
- You can set a custom print quality level in the Print Quality Settings dialog box. To display the Print Quality Settings dialog box, select Custom for Print Quality and click Quality Settings....
- You can specify the print range and the amount of extension for borderless printing in the Print Settings dialog box. To display the Print Settings dialog box, click Advanced....

3. Click Print.

Note

- See Help for details on the Print Settings screen.



[Page top](#)↑

Advanced Guide

Advanced Guide > Printing from a Computer > Printing with the Bundled Application Software > Printing Stickers

Easy-PhotoPrint EX

Printing Stickers

You can print your favorite photos on compatible sticker sheets.



Steps

1. Starting Easy-PhotoPrint EX
2. Selecting the Paper and Layout
3. Selecting a Photo
4. Editing
5. Printing

Try This

- ➔ Correcting and Enhancing Photos
- ➔ Adding Photos
- ➔ Swapping Positions of Photos
- ➔ Replacing Photos
- ➔ Changing Position, Angle and Size of Photos
- ➔ Cropping Photos
- ➔ Framing Photos
- ➔ Adding Text to Photos
- ➔ Saving
- ➔ Opening Saved Files

Questions and Answers

- ➔ How Can I Move (or Copy) the Saved File?

Advanced Guide

Advanced Guide > Printing from a Computer > Printing with the Bundled Application Software > Printing Stickers > Starting Easy-PhotoPrint EX

Easy-PhotoPrint EX



Starting Easy-PhotoPrint EX

1. From the Start menu, select (All) Programs > Canon Utilities > Easy-PhotoPrint EX > Easy-PhotoPrint EX.

Easy-PhotoPrint EX starts and Menu appears.

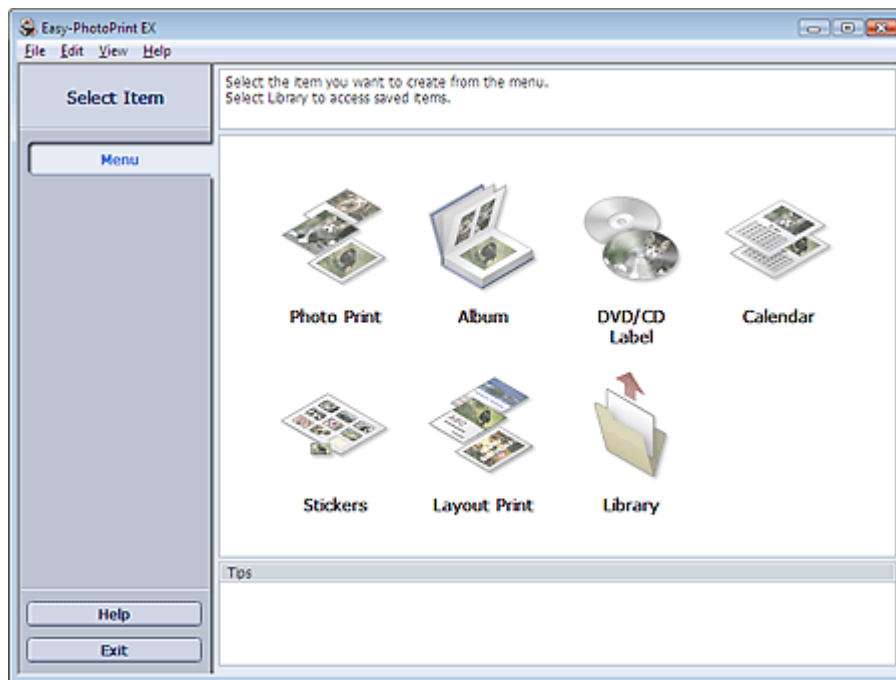

[Page top](#)

Advanced Guide

Advanced Guide > Printing from a Computer > Printing with the Bundled Application Software > Printing Stickers > Selecting the Paper and Layout

Easy-PhotoPrint EX



Selecting the Paper and Layout

1. Click Stickers from Menu.

The Page Setup screen appears.

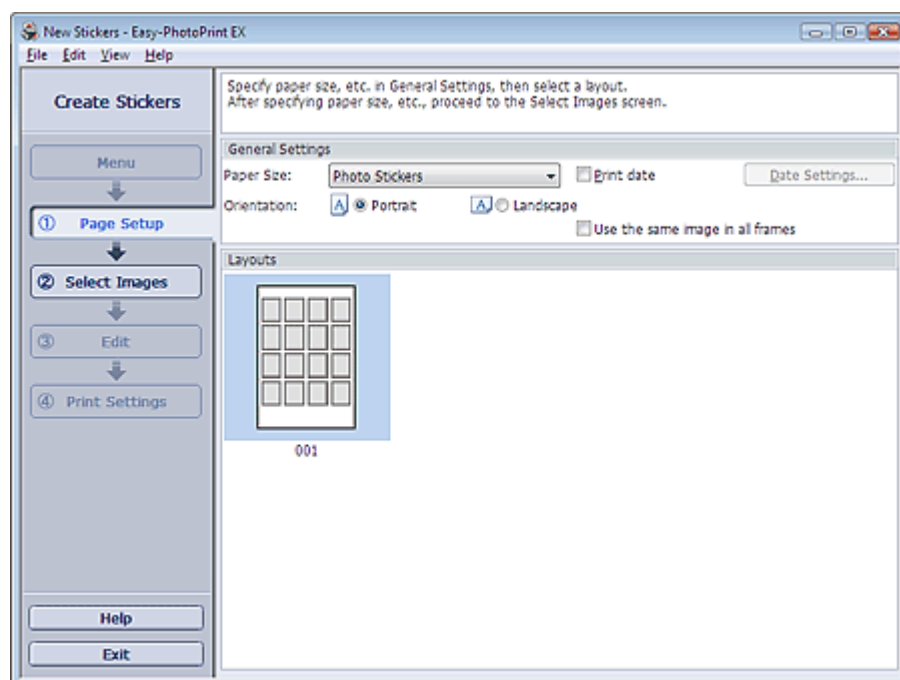

2. Set the following items in the General Settings section:

Paper Size

Orientation

Print date

Use the same image in all frames

Note

- Paper sizes other than Photo Stickers cannot be selected.
- Select the Use the same image in all frames checkbox to use the same image in all the frames on the page.
- You can customize the date (position, size, color, etc.) in the Date Settings dialog box. To display the Date Settings dialog box, select the Print date checkbox and click Date Settings....

Note

- See Help for details on the Page Setup screen.



Page top↑

Advanced Guide

Advanced Guide > Printing from a Computer > Printing with the Bundled Application Software > Printing Stickers > Selecting a Photo

Easy-PhotoPrint EX



Selecting a Photo

1. Click Select Images.

The Select Images screen appears.

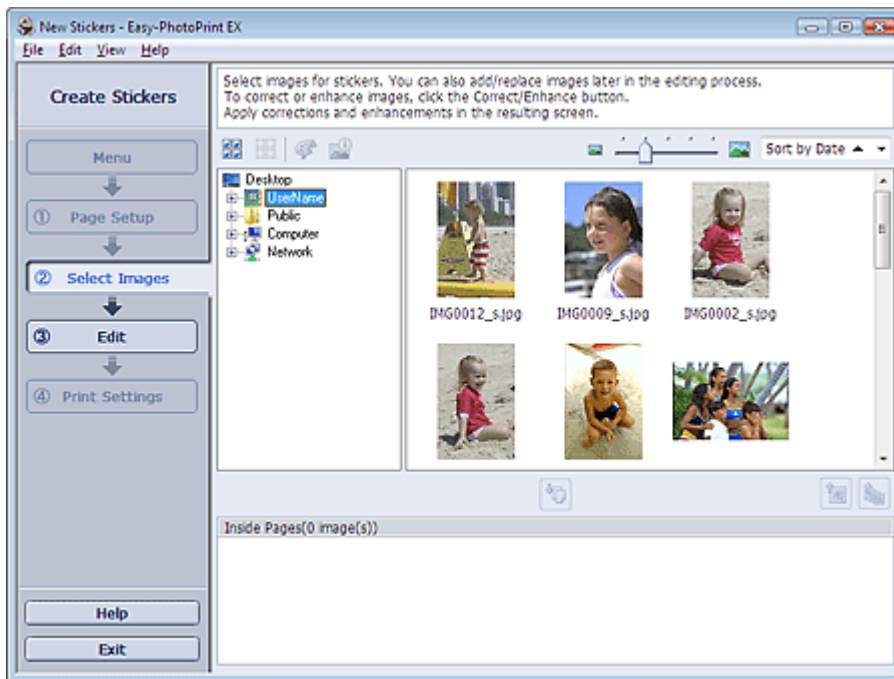

2. Select the folder that contains the image you want to print from the folder tree area.

The images in the folder will be displayed as thumbnails (miniatures).

3. Select the image(s) you want to print and click (Import to Inside Pages).

The selected image(s) are displayed in the selected image area.

You can also select the image(s) you want to print by dragging them into the selected image area.

Note

- To delete an image in the selected image area, select the image you want to delete and click



(Delete Imported Image).

To delete all images from the selected image area, click



(Delete All Imported Images).

Note

- See Help for details on the Select Images screen.



Advanced Guide

Advanced Guide > Printing from a Computer > Printing with the Bundled Application Software > Printing Stickers > Editing

Easy-PhotoPrint EX



Editing

1. Click Edit.

The Edit screen appears.

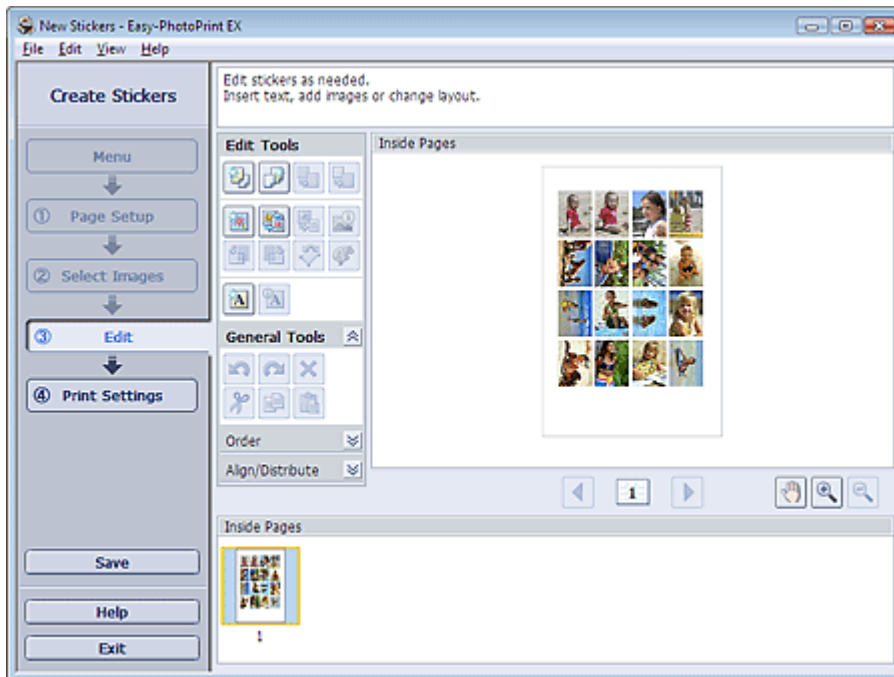

2. Edit the stickers if necessary.

- ➔ Adding Photos
- ➔ Swapping Positions of Photos
- ➔ Replacing Photos
- ➔ Changing Position, Angle and Size of Photos
- ➔ Cropping Photos
- ➔ Printing Dates on Photos
- ➔ Adding Text to Photos

Important

- The edit information will be discarded if you exit Easy-PhotoPrint EX without saving the edited stickers. It is recommended that you save the item if you want to edit it again.
- ➔ Saving

Note

- See Help for details on the Edit screen.



Page top↑

Advanced Guide

Advanced Guide > Printing from a Computer > Printing with the Bundled Application Software > Printing Stickers > Printing

Easy-PhotoPrint EX



Printing

1. Click Print Settings.

The Print Settings screen appears.

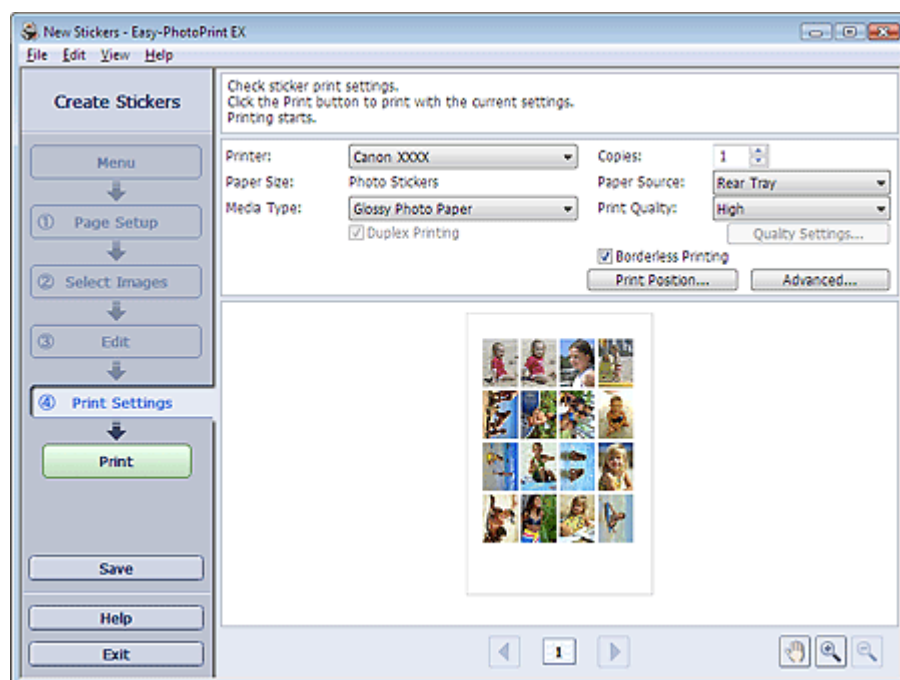

2. Set the following items according to the printer and paper to be used:

Printer

Media Type

Copies

Paper Source

Print Quality

Borderless Printing

Note

- The media types may vary depending on the printer and the paper size.
- The paper sources may vary depending on the printer and the media type.
- You can set a custom print quality level in the Print Quality Settings dialog box. To display the Print Quality Settings dialog box, select Custom for Print Quality and click Quality Settings....
- You can adjust the printing position in the Adjust Print Position dialog box. To display the Adjust Print Position dialog box, click Print Position....
- You can specify the print range and the amount of extension for borderless printing in the Print Settings dialog box. To display the Print Settings dialog box, click Advanced....

3. Click Print.

Note

- See Help for details on the Print Settings screen.



Advanced Guide

Advanced Guide > Printing from a Computer > Printing with the Bundled Application Software > Printing Layout

Easy-PhotoPrint EX

Printing Layout

You can add text to your favorite photos and print them in a variety of layouts.



Steps

1. Starting Easy-PhotoPrint EX
2. Selecting the Paper and Layout
3. Selecting a Photo
4. Editing
5. Printing

Try This

- ➔ Correcting and Enhancing Photos
- ➔ Changing Layout
- ➔ Adding Photos
- ➔ Swapping Positions of Photos
- ➔ Replacing Photos
- ➔ Changing Position, Angle and Size of Photos
- ➔ Cropping Photos
- ➔ Printing Dates on Photos
- ➔ Adding Text to Photos
- ➔ Saving
- ➔ Opening Saved Files

Questions and Answers

- ➔ How Can I Move (or Copy) the Saved File?

Advanced Guide

Advanced Guide > Printing from a Computer > Printing with the Bundled Application Software > Printing Layout > Starting Easy-PhotoPrint EX

Easy-PhotoPrint EX



Starting Easy-PhotoPrint EX

1. From the Start menu, select (All) Programs > Canon Utilities > Easy-PhotoPrint EX > Easy-PhotoPrint EX.

Easy-PhotoPrint EX starts and Menu appears.

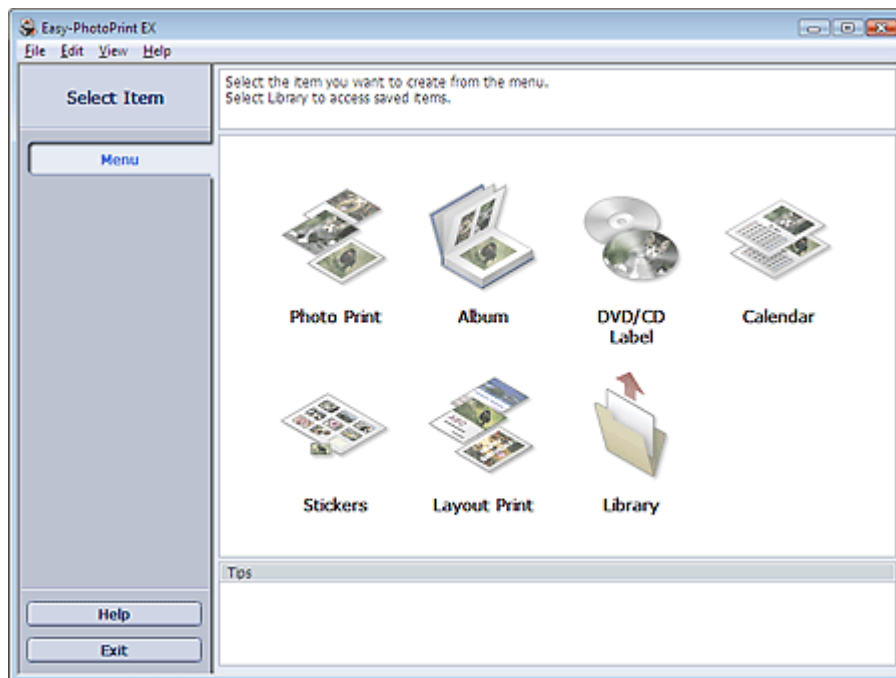

[Page top](#)

Advanced Guide

Advanced Guide > Printing from a Computer > Printing with the Bundled Application Software > Printing Layout > Selecting the Paper and Layout

Easy-PhotoPrint EX



Selecting the Paper and Layout

1. Click Layout Print from Menu.

The Page Setup screen appears.

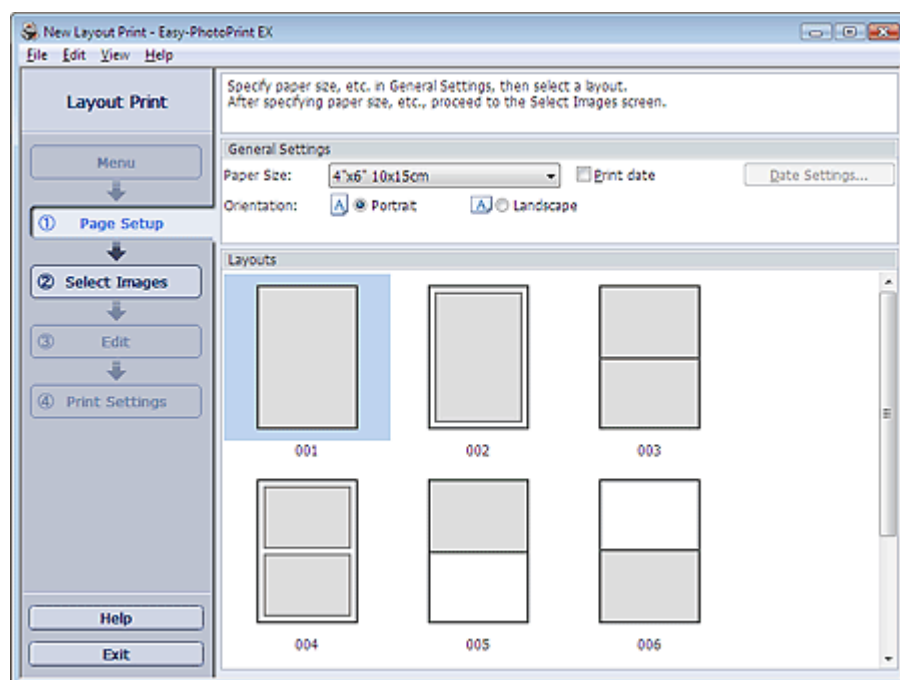

2. Set the following items in the General Settings section:

Paper Size

Orientation

Print date

Note

- See Help on the paper size that can be selected.
- You can customize the date (position, size, color, etc.) in the Date Settings dialog box. To display the Date Settings dialog box, select the Print date checkbox and click Date Settings....

3. Select a layout from Layouts.

Note

- The layouts may vary depending on the Orientation.

Note

- See Help for details on the Page Setup screen.



Advanced Guide

Advanced Guide > Printing from a Computer > Printing with the Bundled Application Software > Printing Layout > Selecting a Photo

Easy-PhotoPrint EX



Selecting a Photo

1. Click Select Images.

The Select Images screen appears.

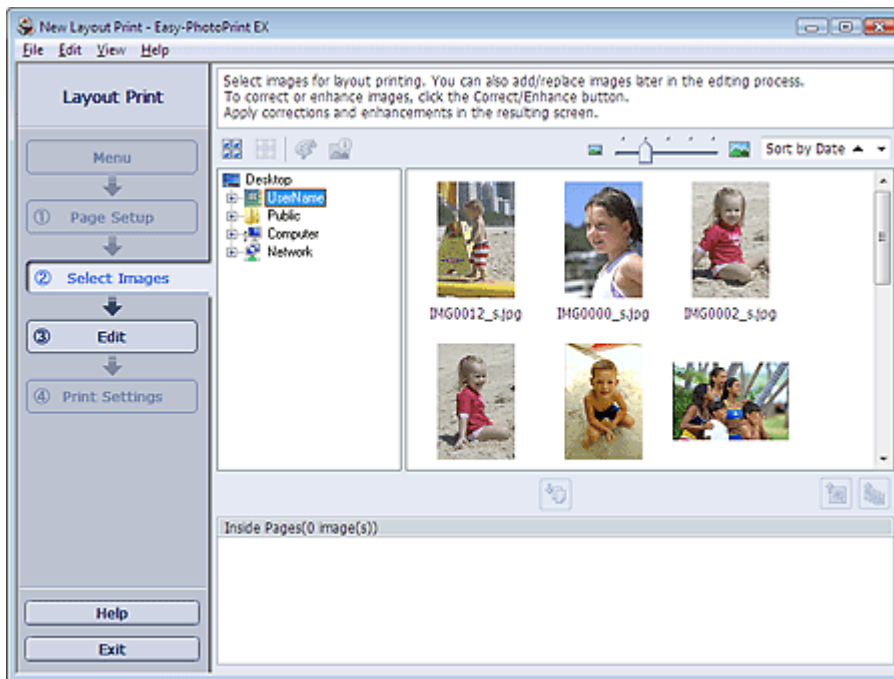

2. Select the folder that contains the image you want to print from the folder tree area.

The images in the folder will be displayed as thumbnails (miniatures).

3. Select the image(s) you want to print and click (Import to Inside Pages).

The selected image(s) are displayed in the selected image area.

You can also select the image(s) you want to print by dragging them into the selected image area.

Note

- To delete an image in the selected image area, select the image you want to delete and click



(Delete Imported Image).

To delete all images from the selected image area, click



(Delete All Imported Images).

Note

- See Help for details on the Select Images screen.



Advanced Guide

Advanced Guide > Printing from a Computer > Printing with the Bundled Application Software > Printing Layout > Editing

Easy-PhotoPrint EX



Editing

1. Click Edit.

The Edit screen appears.

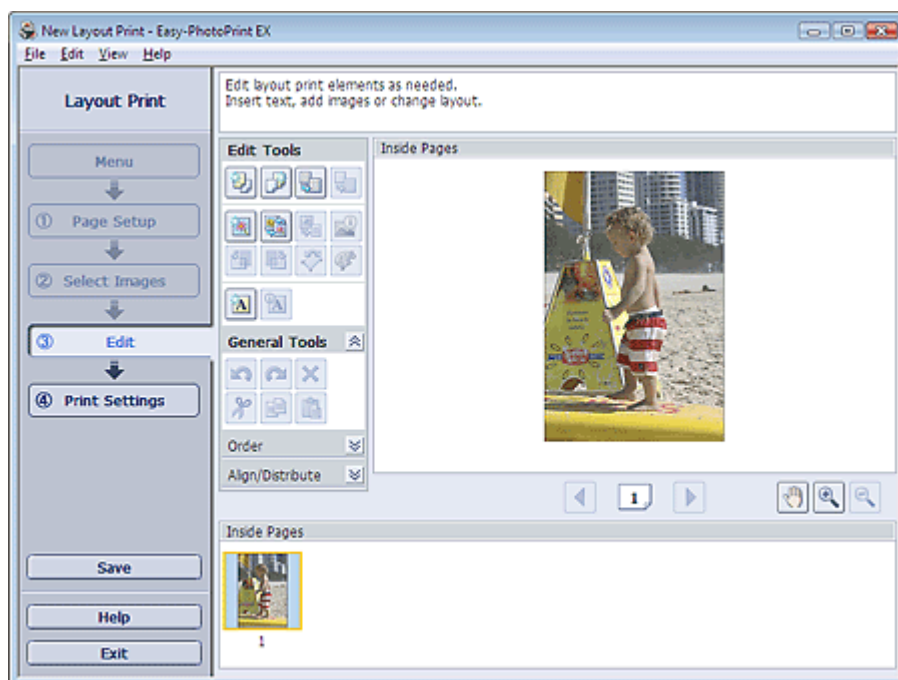

2. Edit the layout if necessary.

- ➔ Changing Layout
- ➔ Adding Photos
- ➔ Swapping Positions of Photos
- ➔ Replacing Photos
- ➔ Changing Position, Angle and Size of Photos
- ➔ Cropping Photos
- ➔ Printing Dates on Photos
- ➔ Adding Text to Photos

Important

- The edit information will be discarded if you exit Easy-PhotoPrint EX without saving the edited layout. It is recommended that you save the item if you want to edit it again.
 - ➔ Saving

Note

- See Help for details on the Edit screen.



Page top↑

Advanced Guide

Advanced Guide > Printing from a Computer > Printing with the Bundled Application Software > Printing Layout > Printing

Easy-PhotoPrint EX



Printing

1. Click Print Settings.

The Print Settings screen appears.

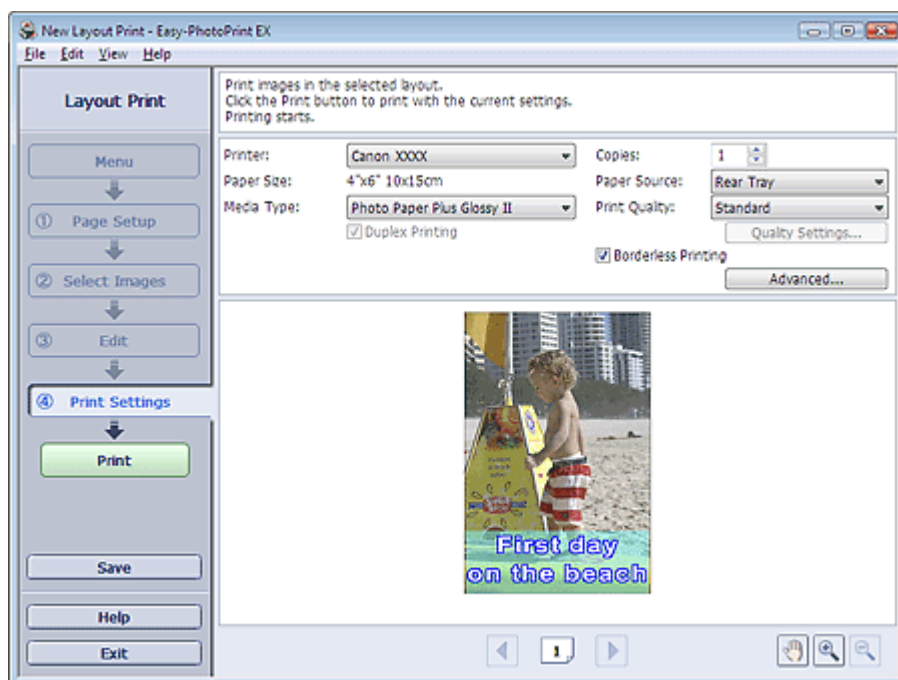

2. Set the following items according to the printer and paper to be used:

- Printer
- Media Type
- Copies
- Paper Source
- Print Quality
- Borderless Printing

Note

- The media types may vary depending on the printer and the paper size.
- Duplex Printing appears if the selected printer and media type support duplex printing. Select this checkbox to print on both sides of the paper.
- Automatic appears if you select the Duplex Printing checkbox after selecting a printer that supports automatic duplex printing and media type that supports duplex printing. Select this checkbox to print on both sides of the paper automatically.
- The paper sources may vary depending on the printer and the media type.
- You can set a custom print quality level in the Print Quality Settings dialog box. To display the Print Quality Settings dialog box, select Custom for Print Quality and click Quality Settings....
- Select the Borderless Printing checkbox to print borderless photos.
- You can specify the print range and the amount of extension for borderless printing in the Print Settings dialog box. To display the Print Settings dialog box, click Advanced....

3. Click Print.

Note

- See Help for details on the Print Settings screen.



[Page top](#)↑

Advanced Guide

Advanced Guide > Printing from a Computer > Printing with the Bundled Application Software > Correcting and Enhancing Photos

Easy-PhotoPrint EX

Correcting and Enhancing Photos

You can correct and enhance images.

Click  (Correct/Enhance Images) in the Select Images or Edit screen, or in the Layout/Print screen of Photo Print. You can make the following corrections and enhancements in the Correct/Enhance Images window.

Important

- For Photo Print, if you select Enable ICC Profile in the Advanced tab of the Preferences dialog box, you cannot correct/enhance images.

Note

- See "[Correct/Enhance Images Window](#)" for details on the Correct/Enhance Images window.

Auto Photo Fix

This function will automatically analyze the captured scene and apply suitable corrections.

➡ [Using the Auto Photo Fix Function](#)

Red-Eye Correction Function

You can correct red eyes caused by a camera flash.

➡ [Using the Red-Eye Correction Function](#)

Face Brightener Function

You can brighten dark faces caused by bright background.

➡ [Using the Face Brightener Function](#)

Face Sharpener Function

You can sharpen out-of-focus faces in a photo.

➡ [Using the Face Sharpener Function](#)

Digital Face Smoothing Function

You can enhance skin beautifully by removing blemishes and wrinkles.

➡ [Using the Digital Face Smoothing Function](#)

Blemish Remover Function

You can remove moles.

➡ [Using the Blemish Remover Function](#)

Image Adjustment

You can adjust brightness and contrast or sharpen the entire image.

You can also blur the outline of the subjects or remove the base color.

➡ [Adjusting Images](#)

Advanced Guide

Advanced Guide > Printing from a Computer > Printing with the Bundled Application Software > Correcting and Enhancing Photos > Using the Auto Photo Fix Function

Easy-PhotoPrint EX

Using the Auto Photo Fix Function

Apply optimum corrections automatically to the photos used for an album, calendar, etc.

Important

- The Auto Photo Fix function is not available for Photo Print. Photo Print allows you to automatically apply suitable corrections to all photos when printing, by selecting Auto Photo Fix in Color correction for printing on the Advanced tab of the Preferences dialog box. To display the Preferences dialog box, click  (Settings) in the Layout/Print screen or select Preferences... from the File menu.
- Once image is corrected with Auto Photo Fix and saved, it cannot be corrected again with Auto Photo Fix. Also, Auto Photo Fix may not be available for images edited using an application, digital camera, etc. manufactured by other companies.

1. Select photos in the Select Images screen, then click  (Correct/Enhance Images).

The Correct/Enhance Images window appears.



Note

- You can also display the Correct/Enhance Images window by clicking  (Correct/Enhance Images) in the Layout/Print or Edit screen. In that case, only the image displayed in Preview can be corrected/enhanced.
- See "[Correct/Enhance Images Window](#)" for details on the Correct/Enhance Images window.

2. Select the image you want to correct from the list displayed in the lower part of the Correct/Enhance Images window.

The image appears in Preview.

Note

- If only one image is selected, the thumbnail does not appear below Preview.

3. Make sure that Auto is selected.

4. Click Auto Photo Fix, then click OK.

The entire photo is corrected automatically and the  (Correction/Enhancement) mark appears on the upper left of the image.

Note

- Click  (Compare) to display the images before and after the correction side by side so that you can compare and check the result.
 - Click Reset Selected Image to undo the correction operation.
 - If you want to apply the correction to all the selected images at once, select the Apply to all images checkbox.
-

5. Click Save Selected Image or Save All Corrected Images.

You can save corrected images as new files.

Note

- To save only the image you like, click Save Selected Image. To save all images, click Save All Corrected Images.
 - Only JPEG/Exif file format is available for corrected images.
-

6. Click Exit.

Important

- The corrections will be lost if you exit before saving corrected images.
-

[Page top](#)

Advanced Guide

Advanced Guide > Printing from a Computer > Printing with the Bundled Application Software > Correcting and Enhancing Photos > Using the Red-Eye Correction Function

Easy-PhotoPrint EX

Using the Red-Eye Correction Function

You can correct red eyes caused by a camera flash.

You can perform the Red-Eye Correction function either automatically or manually.

Note

- Photo Print allows you to automatically correct red eyes when printing. To correct automatically, select Enable Auto Photo Fix in Color correction for printing on the Advanced tab of the Preferences dialog box and select the Enable Red-Eye Correction checkbox.

- Select photos in the Select Images screen, then click  (Correct/Enhance Images).

The Correct/Enhance Images window appears.

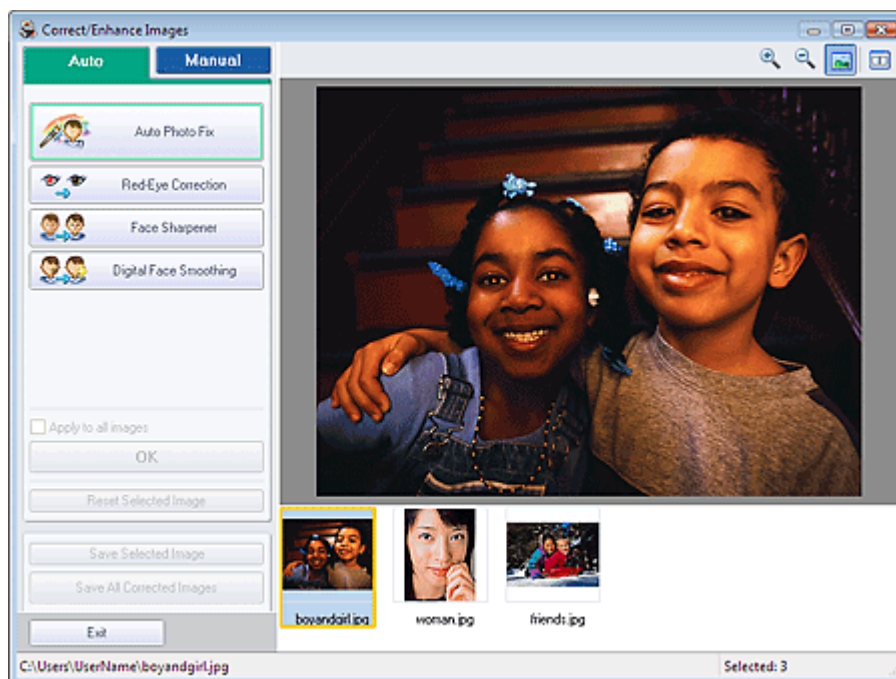

Note

- You can also display the Correct/Enhance Images window by clicking  (Correct/Enhance Images) in the Layout/Print or Edit screen. In that case, only the image displayed in Preview can be corrected/enhanced.
- See "[Correct/Enhance Images Window](#)" for details on the Correct/Enhance Images window.

- Select the image you want to correct from the list displayed in the lower part of the Correct/Enhance Images window.

The image appears in Preview.

Note

- If only one image is selected, the thumbnail does not appear below Preview.

Auto Correction

- Make sure that Auto is selected.

4. Click Red-Eye Correction.

5. Click OK.

Red eyes are corrected and the  (Correction/Enhancement) mark appears on the upper left of the image.

Important

- Areas other than the eyes may be corrected depending on the image.

Note

- Click  (Compare) to display the images before and after the correction side by side so that you can compare and check the result.
- Click Reset Selected Image to undo the correction operation.
- If you want to apply the correction to all the selected images at once, select the Apply to all images checkbox.

Manual Correction

3. Click Manual, then click Correct/Enhance.

4. Click Red-Eye Correction.

Move the cursor over the image. The shape of the cursor changes to  (Paintbrush).



5. Drag to select the red area you want to correct, then click OK that appears over the image.

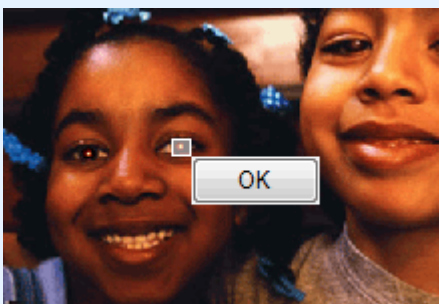

Red eye is corrected and the  (Correction/Enhancement) mark appears on the upper left of the image.

Note

- Effect levels can be changed using the slider below Red-Eye Correction.
- Click Undo to undo the preceding correction operation.

6. Click Save Selected Image or Save All Corrected Images.

You can save corrected images as new files.

Note

- To save only the image you like, click Save Selected Image. To save all images, click Save All Corrected Images.
 - Only JPEG/Exif file format is available for corrected images.
-

7. Click Exit.

Important

- The corrections will be lost if you exit before saving corrected images.

[Page top](#)↑

Advanced Guide

Advanced Guide > Printing from a Computer > Printing with the Bundled Application Software > Correcting and Enhancing Photos > Using the Face Brightener Function

Easy-PhotoPrint EX

Using the Face Brightener Function

You can brighten dark faces caused by bright background.

1. Select photos in the Select Images screen, then click  (Correct/Enhance Images).

The Correct/Enhance Images window appears.



Note

- You can also display the Correct/Enhance Images window by clicking  (Correct/Enhance Images) in the Layout/Print or Edit screen. In that case, only the image displayed in Preview can be corrected/enhanced.
- See "[Correct/Enhance Images Window](#)" for details on the Correct/Enhance Images window.

2. Select the image you want to correct from the list displayed in the lower part of the Correct/Enhance Images window.

The image appears in Preview.

Note

- If only one image is selected, the thumbnail does not appear below Preview.

3. Click Manual, then click Correct/Enhance.

4. Click Face Brightener.

Move the cursor over the image. The shape of the cursor changes to  (Cross).

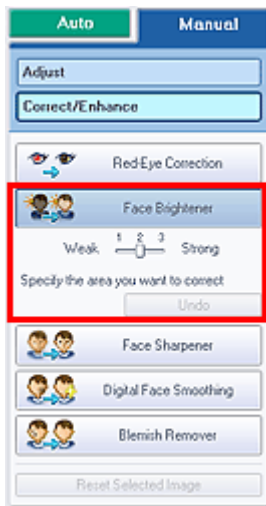

5. Drag to select the area you want to correct, then click OK that appears over the image.

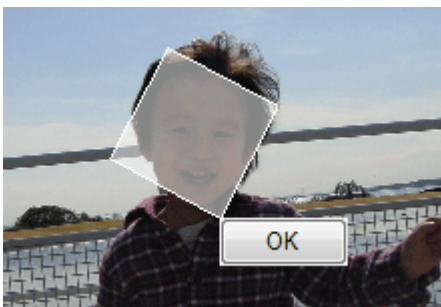

The entire image is corrected so that the selected area containing the face becomes brighter, and the 🗑️ (Correction/Enhancement) mark appears on the upper left of the image.

Note

- You can also drag to rotate the selected area.
- Effect levels can be changed using the slider below Face Brightener.
- Click Undo to undo the preceding correction operation.

6. Click Save Selected Image or Save All Corrected Images.

You can save corrected images as new files.

Note

- To save only the image you like, click Save Selected Image. To save all images, click Save All Corrected Images.
- Only JPEG/Exif file format is available for corrected images.

7. Click Exit.

Important

- The corrections will be lost if you exit before saving corrected images.

Advanced Guide

Advanced Guide > Printing from a Computer > Printing with the Bundled Application Software > Correcting and Enhancing Photos > Using the Face Sharpener Function

Easy-PhotoPrint EX

Using the Face Sharpener Function

You can sharpen out-of-focus faces in a photo.

You can perform the Face Sharpener function either automatically or manually.

1. Select photos in the Select Images screen, then click  (Correct/Enhance Images).

The Correct/Enhance Images window appears.

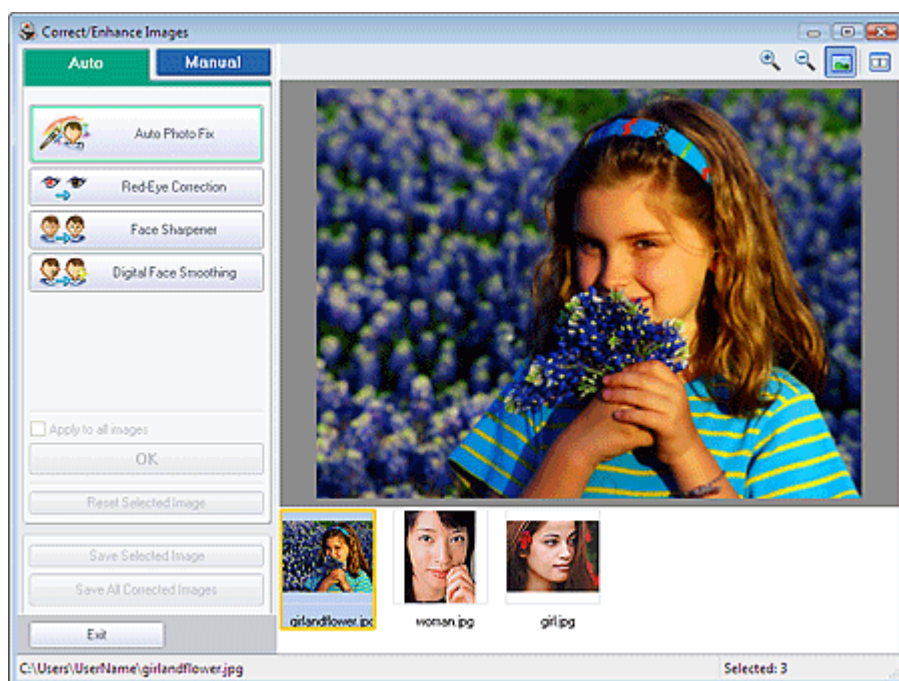

Note

- You can also display the Correct/Enhance Images window by clicking  (Correct/Enhance Images) in the Layout/Print or Edit screen. In that case, only the image displayed in Preview can be corrected/enhanced.
- See "[Correct/Enhance Images Window](#)" for details on the Correct/Enhance Images window.

2. Select the image you want to correct from the list displayed in the lower part of the Correct/Enhance Images window.

The image appears in Preview.

Note

- If only one image is selected, the thumbnail does not appear below Preview.

Auto Correction

3. Make sure that Auto is selected.
4. Click Face Sharpener.
5. Click OK.

The face is sharpened and the  (Correction/Enhancement) mark appears on the upper left of the image.

Note

- Effect levels can be changed using the slider below Face Sharpener.
- Click  (Compare) to display the images before and after the correction side by side so that you can compare and check the result.
- Click Reset Selected Image to undo the correction operation.
- If you want to apply the correction to all the selected images at once, select the Apply to all images checkbox.

Manual Correction

3. Click Manual, then click Correct/Enhance.

4. Click Face Sharpener.

Move the cursor over the image. The shape of the cursor changes to  (Cross).



5. Drag to select the area you want to correct, then click OK that appears over the image.

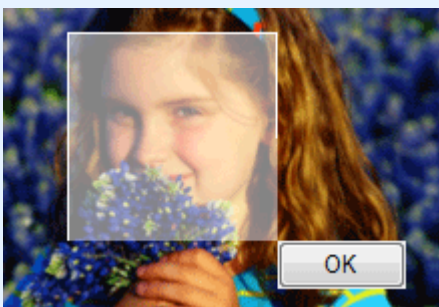

The facial area in and around the selected area is sharpened and the  (Correction/Enhancement) mark appears on the upper left of the image.

Note

- You can also drag to rotate the selected area.
- Effect levels can be changed using the slider below Face Sharpener.
- Click Undo to undo the preceding correction operation.

6. Click Save Selected Image or Save All Corrected Images.

You can save corrected images as new files.

 **Note**

- To save only the image you like, click Save Selected Image. To save all images, click Save All Corrected Images.
- Only JPEG/Exif file format is available for corrected images.

7. Click Exit. **Important**

- The corrections will be lost if you exit before saving corrected images.

[Page top](#)↑

Advanced Guide

Advanced Guide > Printing from a Computer > Printing with the Bundled Application Software > Correcting and Enhancing Photos > Using the Digital Face Smoothing Function

Easy-PhotoPrint EX

Using the Digital Face Smoothing Function

You can enhance skin beautifully by removing blemishes and wrinkles.

You can perform the Digital Face Smoothing function either automatically or manually.

1. Select photos in the Select Images screen, then click  (Correct/Enhance Images).

The Correct/Enhance Images window appears.



Note

- You can also display the Correct/Enhance Images window by clicking  (Correct/Enhance Images) in the Layout/Print or Edit screen. In that case, only the image displayed in Preview can be corrected/enhanced.
- See "[Correct/Enhance Images Window](#)" for details on the Correct/Enhance Images window.

2. Select the image you want to enhance from the list displayed in the lower part of the Correct/Enhance Images window.

The image appears in Preview.

Note

- If only one image is selected, the thumbnail does not appear below Preview.

Auto Enhancement

3. Make sure that Auto is selected.
4. Click Digital Face Smoothing.
5. Click OK.

Skin is enhanced beautifully and the 🎨 (Correction/Enhancement) mark appears on the upper left of the image.

Note

- Effect levels can be changed using the slider below Digital Face Smoothing.
- Click  (Compare) to display the images before and after the enhancement side by side so that you can compare and check the result.
- Click Reset Selected Image to undo the enhancement operation.
- If you want to apply the enhancement to all the selected images at once, select the Apply to all images checkbox.

Manual Enhancement

3. Click Manual, then click Correct/Enhance.

4. Click Digital Face Smoothing.

Move the cursor over the image. The shape of the cursor changes to  (Cross).



5. Drag to select the area you want to enhance, then click OK that appears over the image.

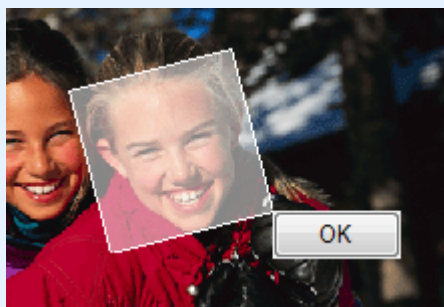

Skin in and around the selected area is enhanced beautifully and the 🎨 (Correction/Enhancement) mark appears on the upper left of the image.

Note

- You can also drag to rotate the selected area.
- Effect levels can be changed using the slider below Digital Face Smoothing.
- Click Undo to undo the preceding enhancement operation.

6. Click Save Selected Image or Save All Corrected Images.

You can save enhanced images as new files.

 **Note**

- To save only the image you like, click Save Selected Image. To save all images, click Save All Corrected Images.
- Only JPEG/Exif file format is available for enhanced images.

7. Click Exit. **Important**

- The enhancements will be lost if you exit before saving enhanced images.

[Page top](#)↑

Advanced Guide

Advanced Guide > Printing from a Computer > Printing with the Bundled Application Software > Correcting and Enhancing Photos > Using the Blemish Remover Function

Easy-PhotoPrint EX

Using the Blemish Remover Function

You can remove moles.

1. Select photos in the Select Images screen, then click  (Correct/Enhance Images).

The Correct/Enhance Images window appears.

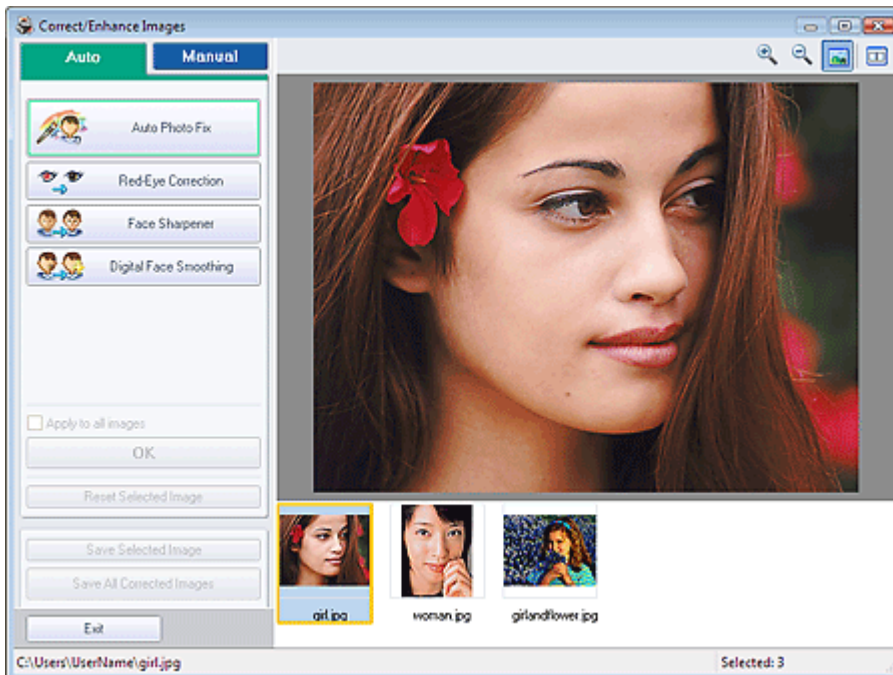

Note

- You can also display the Correct/Enhance Images window by clicking  (Correct/Enhance Images) in the Layout/Print or Edit screen. In that case, only the image displayed in Preview can be corrected/enhanced.
- See "[Correct/Enhance Images Window](#)" for details on the Correct/Enhance Images window.

2. Select the image you want to enhance from the list displayed in the lower part of the Correct/Enhance Images window.

The image appears in Preview.

Note

- If only one image is selected, the thumbnail does not appear below Preview.

3. Click Manual, then click Correct/Enhance.

4. Click Blemish Remover.

Move the cursor over the image. The shape of the cursor changes to  (Cross).



5. Drag to select the area you want to enhance, then click OK that appears over the image.

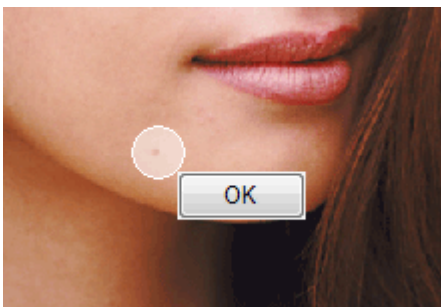

Moles in and around the selected area are removed and the 🧑🏻 (Correction/Enhancement) mark appears on the upper left of the image.

Note

- Click Undo to undo the preceding enhancement operation.

6. Click Save Selected Image or Save All Corrected Images.

You can save enhanced images as new files.

Note

- To save only the image you like, click Save Selected Image. To save all images, click Save All Corrected Images.
- Only JPEG/Exif file format is available for enhanced images.

7. Click Exit.

Important

- The enhancements will be lost if you exit before saving enhanced images.

Advanced Guide

Advanced Guide > Printing from a Computer > Printing with the Bundled Application Software > Correcting and Enhancing Photos > Adjusting Images

Easy-PhotoPrint EX

Adjusting Images

You can make fine adjustments to the overall brightness, contrast, etc. of images.

1. Select photos in the Select Images screen, then click  (Correct/Enhance Images).

The Correct/Enhance Images window appears.

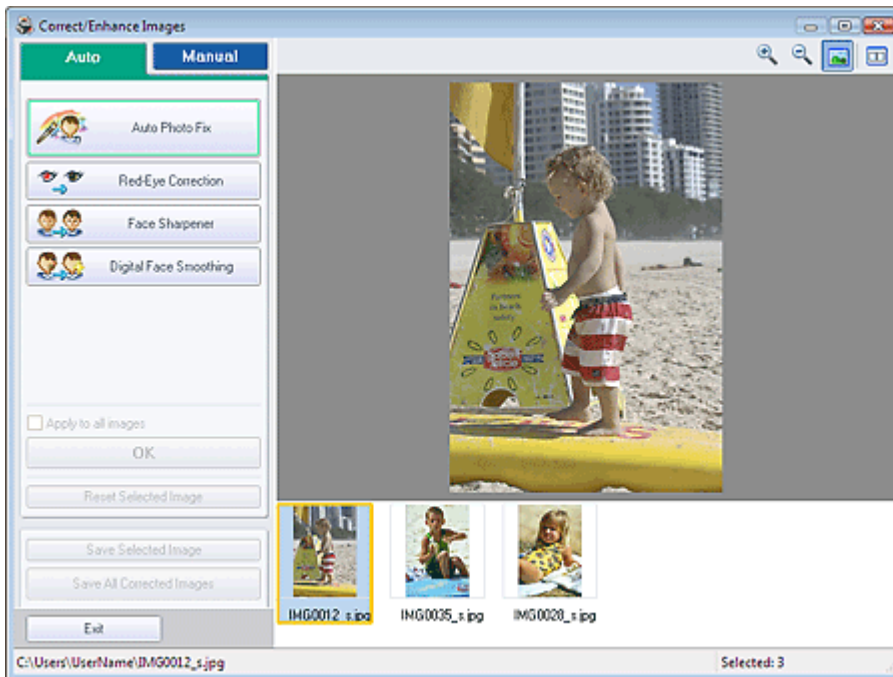

Note

- You can also display the Correct/Enhance Images window by clicking  (Correct/Enhance Images) in the Layout/Print or Edit screen. In that case, only the image displayed in Preview can be corrected/enhanced.
- See "[Correct/Enhance Images Window](#)" for details on the Correct/Enhance Images window.

2. Select the image you want to adjust from the list displayed in the lower part of the Correct/Enhance Images window.

The image appears in Preview.

Note

- If only one image is selected, the thumbnail does not appear below Preview.

3. Click Manual, then click Adjust.
4. Move the slider of the item you want to adjust and set the effect level.

The following adjustments are available:

Brightness

Contrast

Sharpness

Blur

Show-through Removal



Note

- Click Defaults to reset all adjustments.

5. Click Save Selected Image or Save All Corrected Images.

You can save adjusted images as new files.

Note

- To save only the image you like, click Save Selected Image. To save all images, click Save All Corrected Images.
- Only JPEG/Exif file format is available for adjusted images.

6. Click Exit.

Important

- The adjustments will be lost if you exit before saving adjusted images.

Advanced Guide

Advanced Guide > Printing from a Computer > Printing with the Bundled Application Software > Correcting and Enhancing Photos > Correct/Enhance Images Window

Easy-PhotoPrint EX

Correct/Enhance Images Window

You can correct/enhance images in this window.

To display the Correct/Enhance Images window, click  (Correct/Enhance Images) in the Select Images or Edit screen, or in the Layout/Print screen of Photo Print.

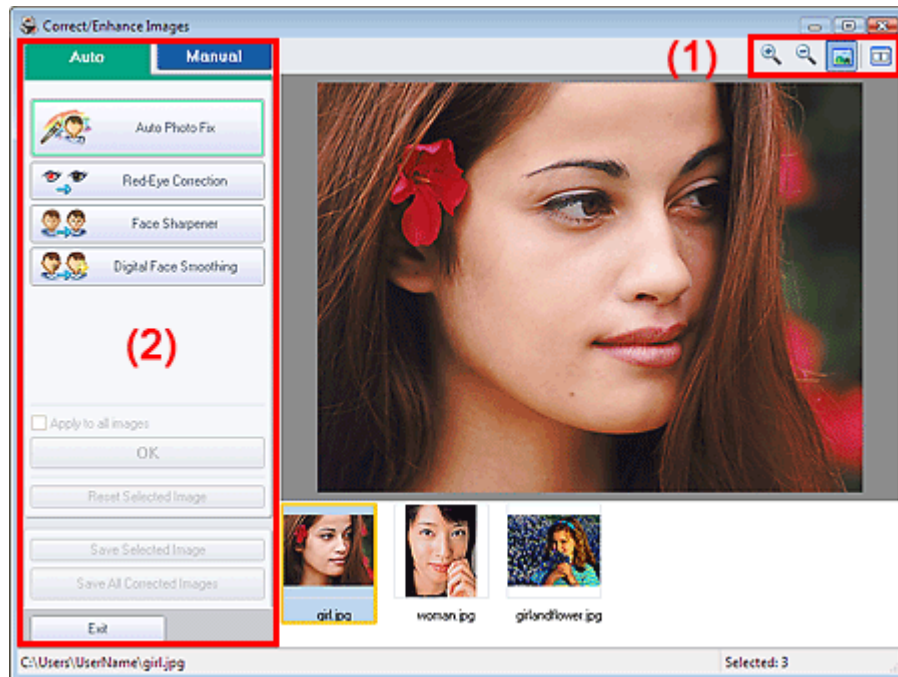

(1)Toolbar

Toolbar



(Zoom In/Zoom Out)

Displays the enlarged or reduced preview of the page.



(Full Screen)

Displays the entire image in Preview.



(Compare)

Displays the Compare Images window. You can compare the images before and after the correction/enhancement side by side.

The image before the correction/enhancement is displayed on the left, and the image after the correction/enhancement is displayed on the right.

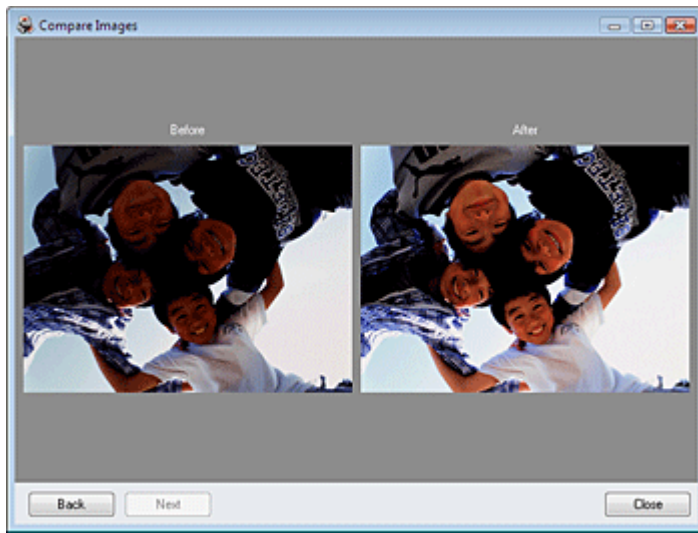

(2)Task Area

Available tasks and settings may vary between the Auto and Manual tabs. Click Auto or Manual to display the corresponding tab.

Auto Tab

Select to correct automatically.

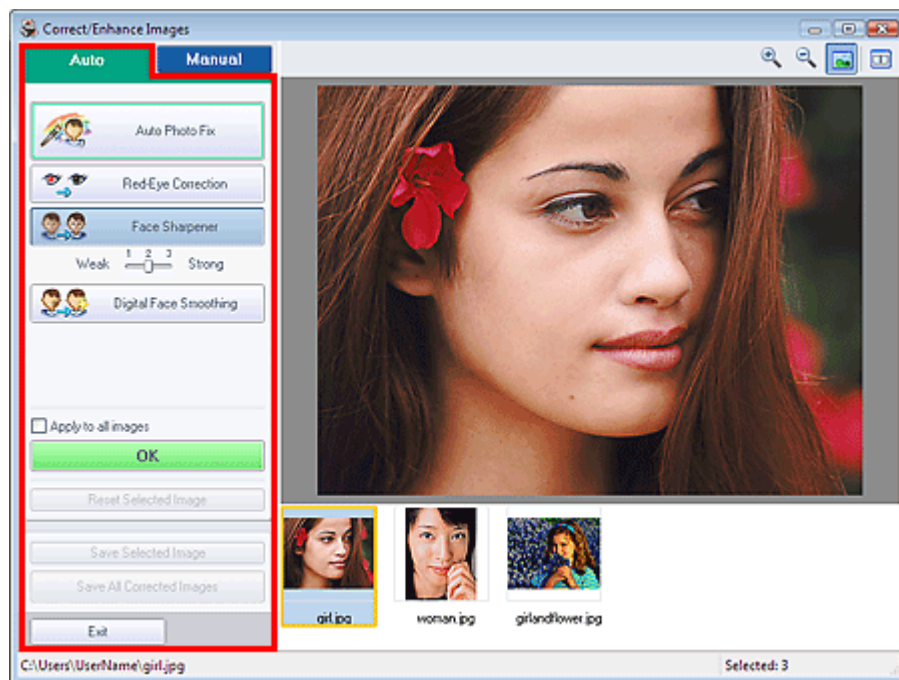

Auto Photo Fix

Applies automatic corrections suitable for photos.

Important

- The Auto Photo Fix function is not available for Photo Print. Photo Print allows you to automatically apply suitable corrections to all photos when printing. Select this option in Color correction for printing on the Advanced tab of the Preferences dialog box. To display the Preferences dialog box, click  (Settings) in the Layout/Print screen or select Preferences... from the File menu.

Red-Eye Correction

Corrects red eyes.

Note

- For Photo Print, you can also correct red eyes by selecting Enable Auto Photo Fix in Color correction for printing on the Advanced tab of the Preferences dialog box and selecting the

Enable Red-Eye Correction checkbox.

Face Sharpener

Sharpens out-of-focus faces.

You can adjust the effect level using the slider.

Digital Face Smoothing

Enhances skin beautifully by removing blemishes and wrinkles.

You can adjust the effect level using the slider.

Apply to all images

Automatically corrects all the images displayed in the list.

OK

Applies the selected effect to the selected image or all images.

Reset Selected Image

Cancels all corrections and enhancements applied to the selected image.

Save Selected Image

Saves the selected image in the list that applied corrections and enhancements.

Save All Corrected Images

Saves all the images that applied corrections and enhancements displayed in the list.

Exit

Click to close the Correct/Enhance Images window.

Manual Tab

Select to correct manually.

Use Adjust to adjust brightness and contrast, or to sharpen the entire image.

Use Correct/Enhance to correct/enhance specific areas.

Adjust

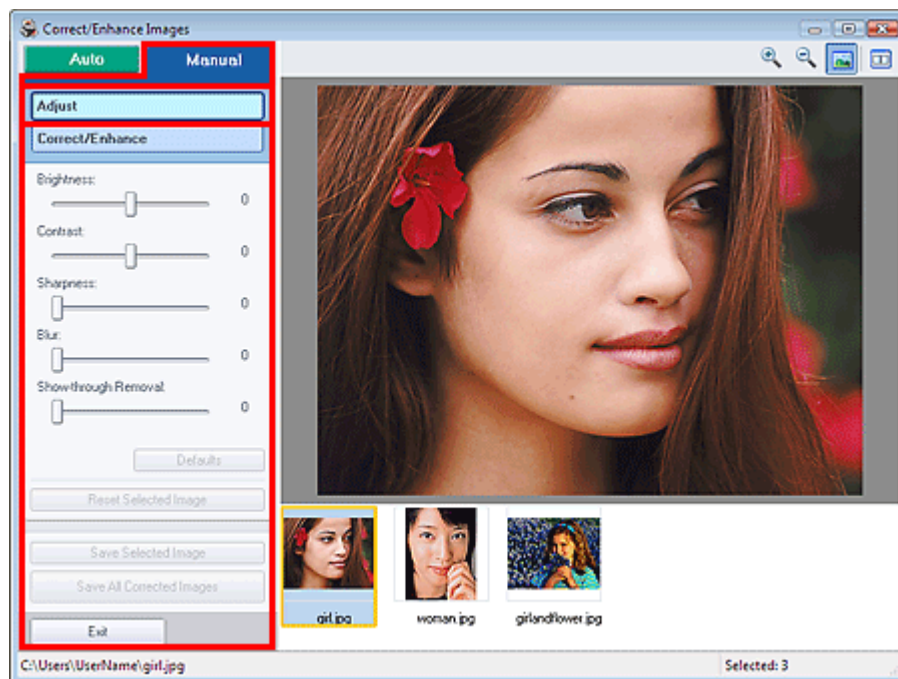

Brightness

Adjusts the overall image brightness.

Move the slider to the left to darken and right to brighten the image.

Contrast

Adjusts the contrast of the image. Adjust the contrast when the image is flat due to lack of contrast.

Move the slider to the left to decrease and right to increase the contrast of the image.

Sharpness

Emphasizes the outline of the subjects to sharpen the image. Adjust the sharpness when the photo is out of focus or text is blurred.

Move the slider to the right to sharpen the image.

Blur

Blurs the outline of the subjects to soften the image.

Move the slider to the right to soften the image.

Show-through Removal

Removes show-through of text from the reverse side or removes the base color. Adjust the show-through level to prevent text on the reverse side of thin document or the base color of the document from appearing on the image.

Move the slider to the right to increase the show-through removal effect.

Defaults

Resets each adjustment (brightness, contrast, sharpness, blur, and show-through removal).

Reset Selected Image

Cancels all adjustments applied to the selected image.

Save Selected Image

Saves the selected image in the list that applied adjustments.

Save All Corrected Images

Saves all the images that applied adjustments displayed in the list.

Exit

Click to close the Correct/Enhance Images window.

Correct/Enhance



Red-Eye Correction

Corrects red eyes.

You can specify the area you want to apply the effect to. You can adjust the effect level using the slider.

Note

- For Photo Print, red eyes are automatically corrected when Enable Auto Photo Fix is selected in Color correction for printing on the Advanced tab of the Preferences dialog box and the Enable Red-Eye Correction checkbox is selected. To disable the automatic correction, deselect the checkbox.

Face Brightener

Corrects the entire image so that the selected facial area is brightened.

You can adjust the effect level using the slider.

Face Sharpener

Sharpens out-of-focus faces.

You can specify the area you want to apply the effect to. You can adjust the effect level using the

slider.

Digital Face Smoothing

Enhances skin beautifully by removing blemishes and wrinkles.

You can specify the area you want to apply the effect to. You can adjust the effect level using the slider.

Blemish Remover

Removes moles.

You can specify the area you want to apply the effect to.

OK

Applies the selected effect to the specified area.

Undo

Cancels the latest correction/enhancement.

Reset Selected Image

Cancels all corrections and enhancements applied to the selected image.

Save Selected Image

Saves the selected image in the list that applied corrections and enhancements.

Save All Corrected Images

Saves all the images that applied corrections and enhancements displayed in the list.

Exit

Click to close the Correct/Enhance Images window.

Advanced Guide

[Advanced Guide](#) > [Printing from a Computer](#) > [Printing with the Bundled Application Software](#) > [Questions and Answers](#)

Easy-PhotoPrint EX

Questions and Answers

- [How Can I Move \(or Copy\) the Saved File?](#)
- [Which Side of the Displayed Image Does the Printing Start from?](#)
- [How Do I Print with Even Margins?](#)
- [What Is "C1" or "C4"?](#)

[Page top](#)↑

Advanced Guide

Advanced Guide > Printing from a Computer > Printing with the Bundled Application Software > Questions and Answers
> How Can I Move (or Copy) the Saved File?

Easy-PhotoPrint EX



How Can I Move (or Copy) the Saved File?

If you want to move (or copy) a file created and saved with Easy-PhotoPrint EX from one folder to another, you need to move (or copy) the folder that was automatically created when originally saving that file as well.

For example, when you save a file named "MyAlbum.e11," a folder named "MyAlbum.e11.Data" is automatically created in the same folder that contains the "MyAlbum.e11" file. If you want to move (or copy) the "MyAlbum.e11" file to another folder, move (or copy) the "MyAlbum.e11.Data" folder as well. The "MyAlbum.e11.Data" folder contains the photos used in the album.

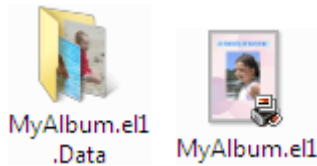

Note

- The icons may vary depending on the items.

Important

- Do not change the Data folder name; otherwise you will not be able to display the photos you edited with Easy-PhotoPrint EX.

[Page top](#)↑

Advanced Guide

Advanced Guide > Printing from a Computer > Printing with the Bundled Application Software > Questions and Answers
> Which Side of the Displayed Image Does the Printing Start from?

Easy-PhotoPrint EX



Which Side of the Displayed Image Does the Printing Start from?

As shown below, printing starts from the left side of the image displayed in the Layout/Print screen.



Outputs the paper in the direction as the arrow indicates.

See your printer manual for details on how to load paper (to print on the front/back, etc.).

[Page top](#) ↑

Advanced Guide

Advanced Guide > Printing from a Computer > Printing with the Bundled Application Software > Questions and Answers
> How Do I Print with Even Margins?

Easy-PhotoPrint EX



How Do I Print with Even Margins?

When you print on a bordered layout, the margins on the left and right or the top and bottom may become wider than the other, depending on the image and printer.

To always print with even margins, select the Always crop images when selecting a layout with margins checkbox on the Advanced tab of the Preferences dialog box.

To display the Preferences dialog box, click  (Settings) in the Layout/Print screen or select Preferences... from the File menu.

Crop the photo to apply even margins individually.

➔ [Cropping Photos \(Photo Print\)](#)

Note

- This setting is available for Photo Print only.

[Page top](#)↑

Advanced Guide

Advanced Guide > Printing from a Computer > Printing with the Bundled Application Software > Questions and Answers
> What Is "C1" or "C4"?

Easy-PhotoPrint EX



What Is "C1" or "C4"?

When an album is printed, labels such as "C1" and "C4" are printed as page numbers.

The "C1" and "C4" represent the front cover and back cover, respectively.

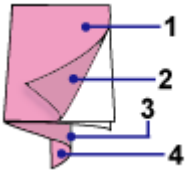

C1: Front cover

C2: Inside the front cover

C3: Inside the back cover

C4: Back cover

[Page top](#)

Advanced Guide

Advanced Guide > Printing from a Computer > Printing with the Bundled Application Software > Photo Print Settings

Easy-PhotoPrint EX

Photo Print Settings

- ➔ [Printing on a DVD/CD](#)
- ➔ [Printing Photos in Grayscale](#)
- ➔ [Printing Vivid Photos](#)
- ➔ [Reducing Photo Noise](#)
- ➔ [Cropping Photos \(Photo Print\)](#)
- ➔ [Printing Dates on Photos \(Photo Print\)](#)
- ➔ [Printing Multiple Photos on One Page](#)
- ➔ [Printing an Index](#)
- ➔ [Printing ID Photos \(ID Photo Print\)](#)
- ➔ [Printing Photo Information](#)
- ➔ [Saving Photos](#)
- ➔ [Opening Saved Files](#)

[Page top](#)↑

Advanced Guide

Advanced Guide > Printing from a Computer > Printing with the Bundled Application Software > Photo Print Settings > Printing on a DVD/CD

Easy-PhotoPrint EX



Printing on a DVD/CD

You can print on a DVD/CD using Photo Print.

Select CD-R for Paper Size in the Select Paper screen, then select a layout and enter the title.

If you want to edit the details, return to Menu and select DVD/CD Label and edit/print using CD-LabelPrint.

Follow the steps for other items to complete image selection in the Select Images screen.

➔ Selecting a Photo

1. Select CD-R for Paper Size in the Select Paper screen.

Set the Printer and Media Type according to the printer and DVD/CD to be used.

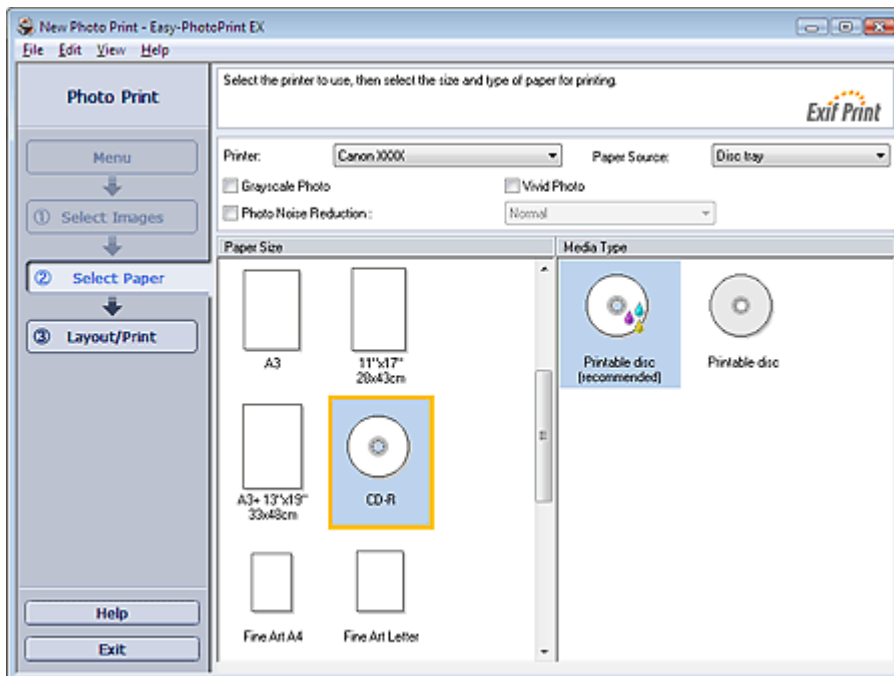

Note

- When CD-R is selected, only Disc tray will be selectable for Paper Source.

2. Click Layout/Print.

The Layout/Print screen appears.

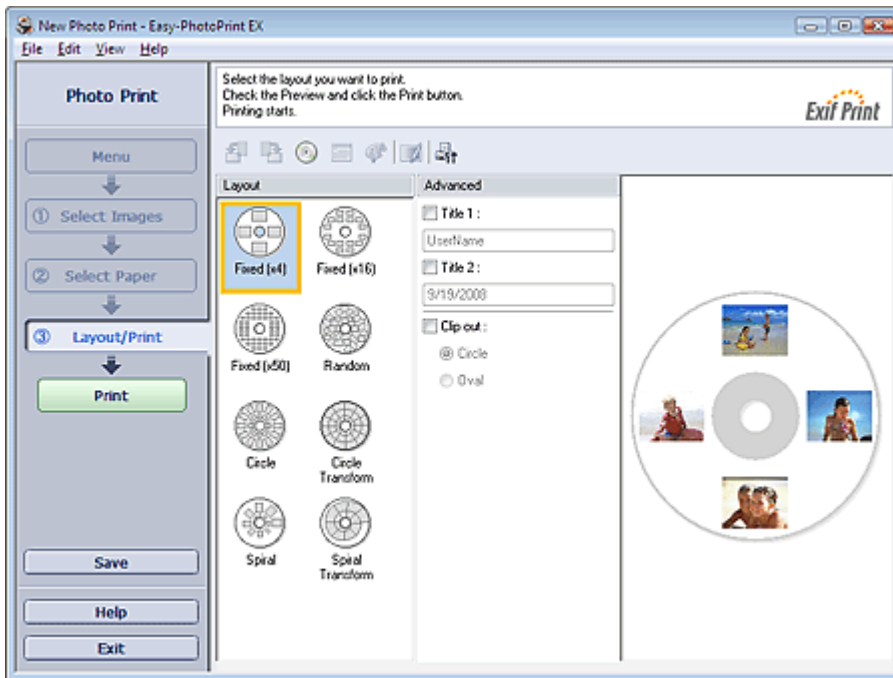

3. Select a layout you want to use.
4. Enter the title(s) and specify the details of the layout in Advanced.

Note

- Items that can be set may vary depending on the selected layout.

5. Click Print.



Set a DVD/CD and print according to the message.

Printing starts from the top of the image displayed in Preview.

Important

- Do not install a CD-R tray until the message prompting you to set a DVD/CD appears.

Note

- You can adjust the printing position on the DVD/CD in the Adjust dialog box. To display the Adjust dialog box, click  (Adjust Print Area/Print Position).
- You can specify advanced Photo Print settings (number of copies, print quality, etc.) in the Preferences dialog box. To display the Preferences dialog box, click  (Settings) or select Preferences... from the File menu.

Advanced Guide

Advanced Guide > Printing from a Computer > Printing with the Bundled Application Software > Photo Print Settings > Printing Photos in Grayscale

Easy-PhotoPrint EX



Printing Photos in Grayscale

Select the Grayscale Photo checkbox in the Select Paper screen to print photos in grayscale.

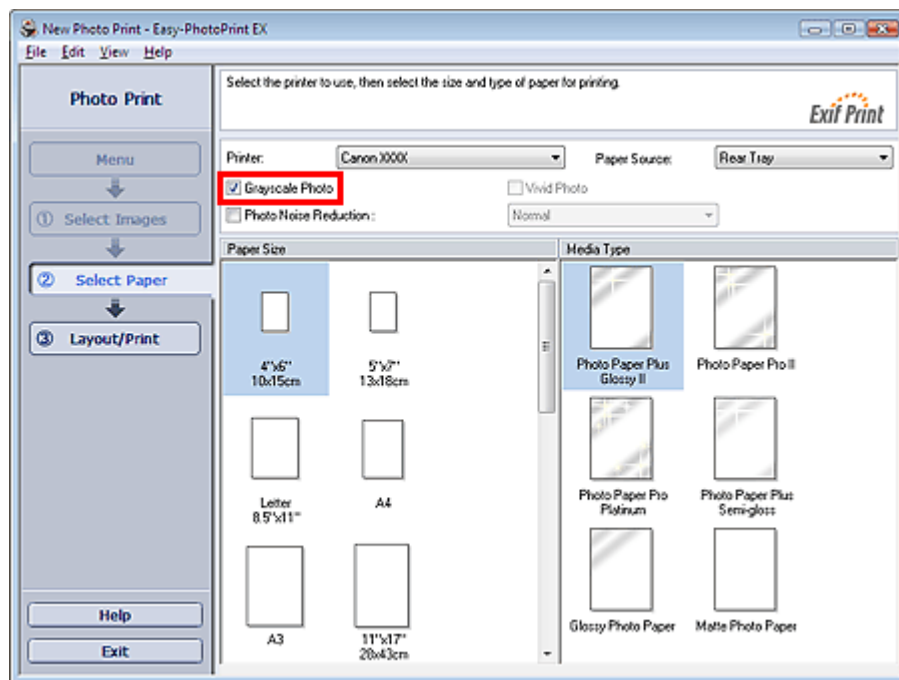

Important

- Vivid Photo is not available when the Grayscale Photo checkbox is selected.
- White streaks may appear at the top and bottom edges of grayscale photos. In that case, print with a 45 mm (1.77 inch) or more margin at the top and bottom edges. If you select Bordered (Margin 45) from the layouts in the Layout/Print screen, images will be reduced when printing to allow a 45 mm (1.77 inch) margin at the top and bottom edges relative to the printing direction.

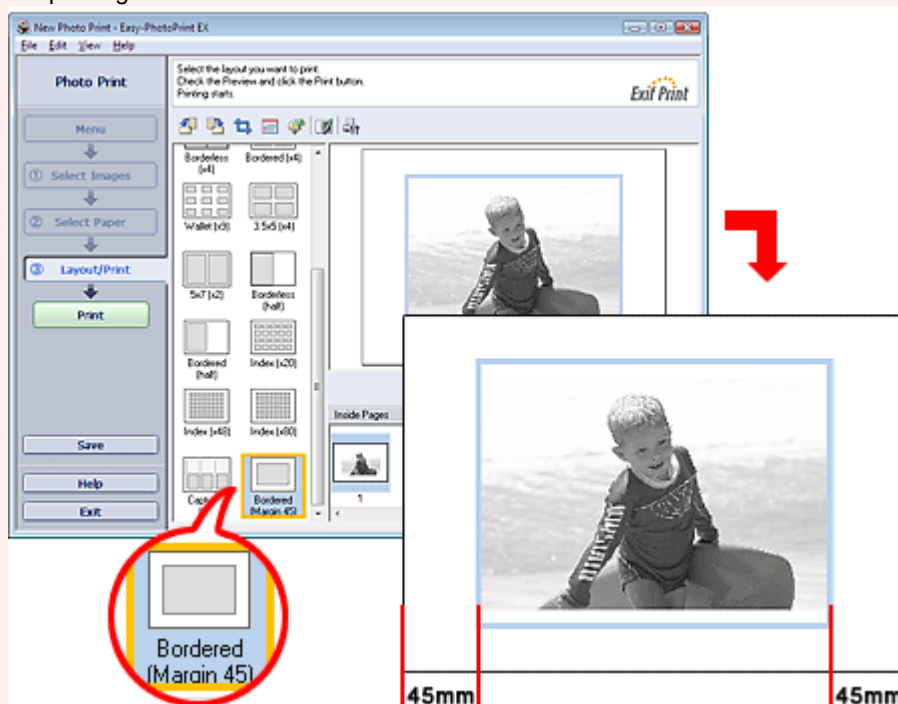

 **Note**

- When the Grayscale Photo checkbox is selected, preview images appear in grayscale in the Layout/Print screen. However, they appear in color in the Correct/Enhance Images window.
- In the Adjust Grayscale window, you can adjust the black color tone of grayscale photos. To display the Adjust Grayscale window, select the Grayscale Photo checkbox in the Select Paper screen and click  (Adjust Grayscale) in the Layout/Print screen. See Help for details.

[Page top](#) 

Advanced Guide

Advanced Guide > Printing from a Computer > Printing with the Bundled Application Software > Photo Print Settings > Printing Vivid Photos

Easy-PhotoPrint EX



Printing Vivid Photos

Select the Vivid Photo checkbox in the Select Paper screen to boost the colors in a photo before printing.

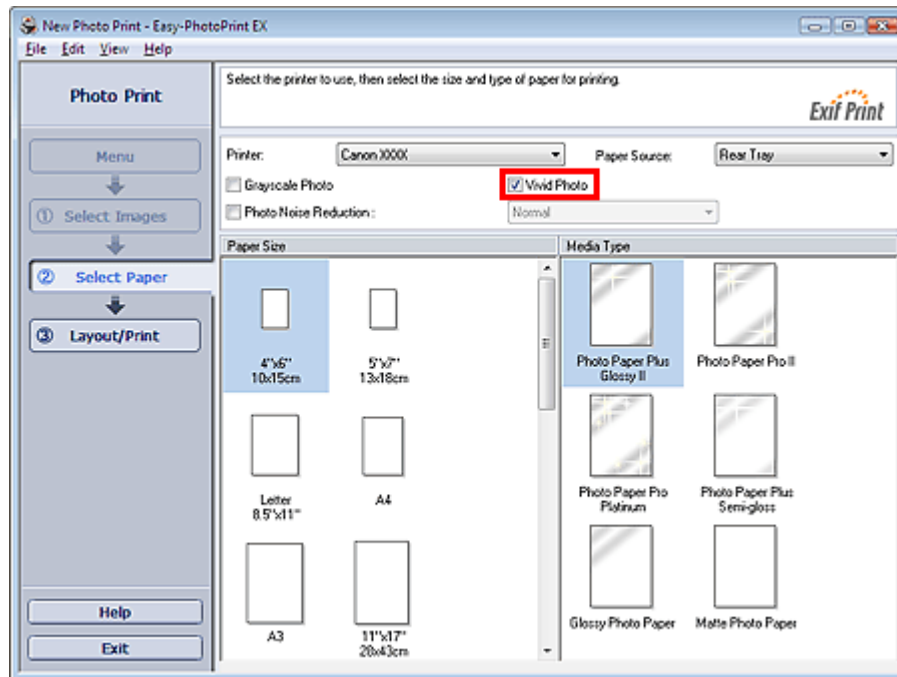

Important

- This function is available only with a printer that supports Vivid Photo.
- This function is not available when Enable ICC Profile is selected on the Advanced tab of the Preferences dialog box.

Note

- Even if you select the Vivid Photo checkbox, this effect applies only to the print result. The original image or preview image will not be affected.

Advanced Guide

Advanced Guide > Printing from a Computer > Printing with the Bundled Application Software > Photo Print Settings > Reducing Photo Noise

Easy-PhotoPrint EX



Reducing Photo Noise

When a photo is taken in a dark location such as night scene using digital camera, noise may appear in the image.

Select the Photo Noise Reduction checkbox in the Select Paper screen to reduce noise in the image and make the printed photos more vivid.

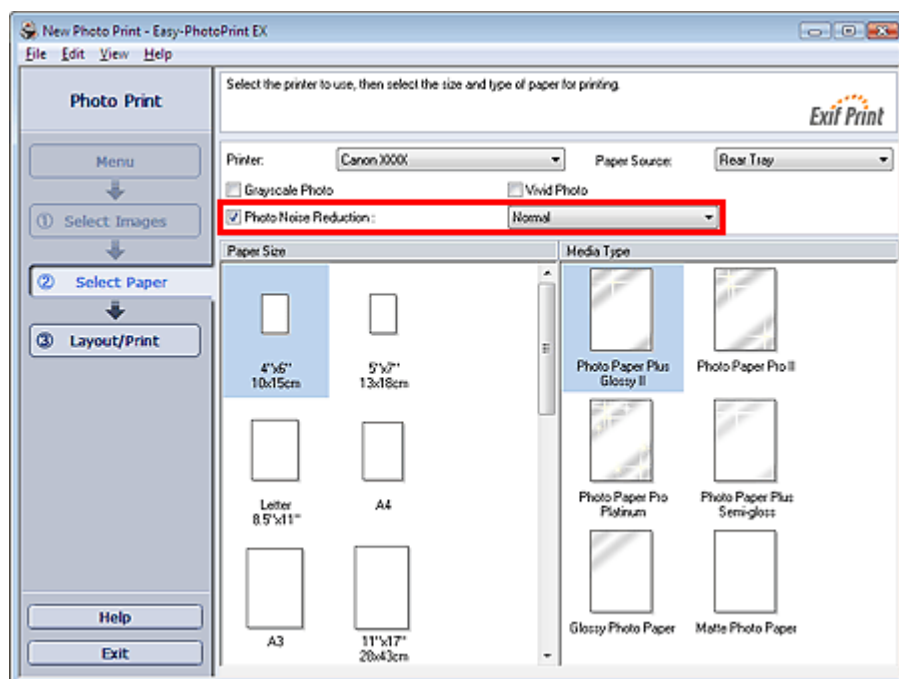

Important

- This function is not available when Enable ICC Profile is selected on the Advanced tab of the Preferences dialog box.

Note

- When the noise is severe, change Normal to Strong.
- The noise reduction effect applies only to the print result. The original image or preview image will not be affected.

[Page top](#)

Advanced Guide

Advanced Guide > Printing from a Computer > Printing with the Bundled Application Software > Photo Print Settings > Cropping Photos (Photo Print)

Easy-PhotoPrint EX



Cropping Photos (Photo Print)

Cropping a photo is the act of removing the unnecessary portions of the photo by selecting the necessary portions.

Click  (Crop Image) in the Layout/Print screen or double-click the preview image. Move the white frame to the portion to print and click OK.

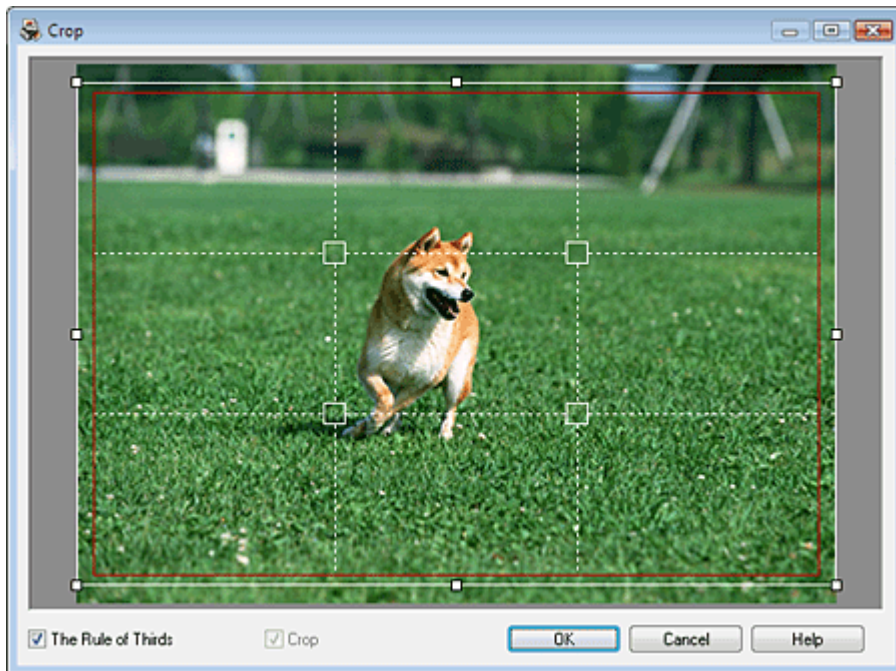

Note

- To move the cropping area, place the cursor within the white frame and drag it. Drag the white lines to enlarge/reduce the cropping area.
- Select the The Rule of Thirds checkbox to display white broken lines. To create a balanced composition, drag any of the intersecting points (white squares) or white broken lines over the main subject of the photo.

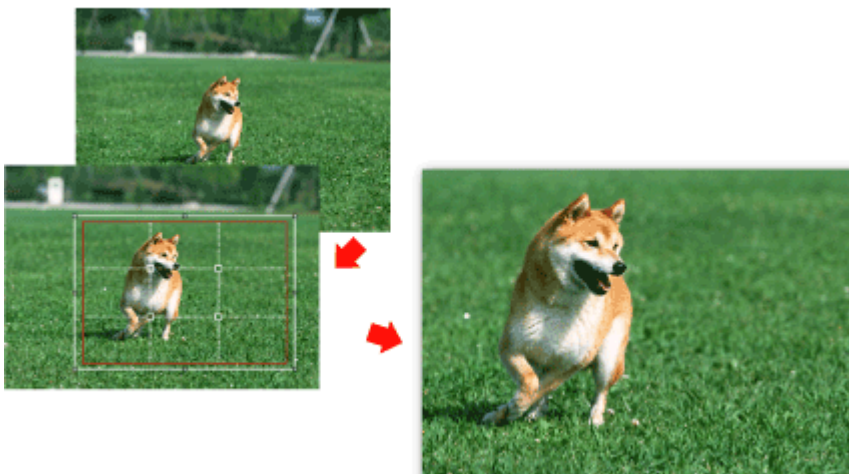

- The cropping effect applies only to the print result. The original image will not be cropped.
- See Help for details on the Crop window.

Advanced Guide

Advanced Guide > Printing from a Computer > Printing with the Bundled Application Software > Photo Print Settings > Printing Dates on Photos (Photo Print)

Easy-PhotoPrint EX



Printing Dates on Photos (Photo Print)

To print the date the photo was taken on the photo, click  (Date Settings) in the Layout/Print screen, then select the Print date checkbox in the Date Settings dialog box.

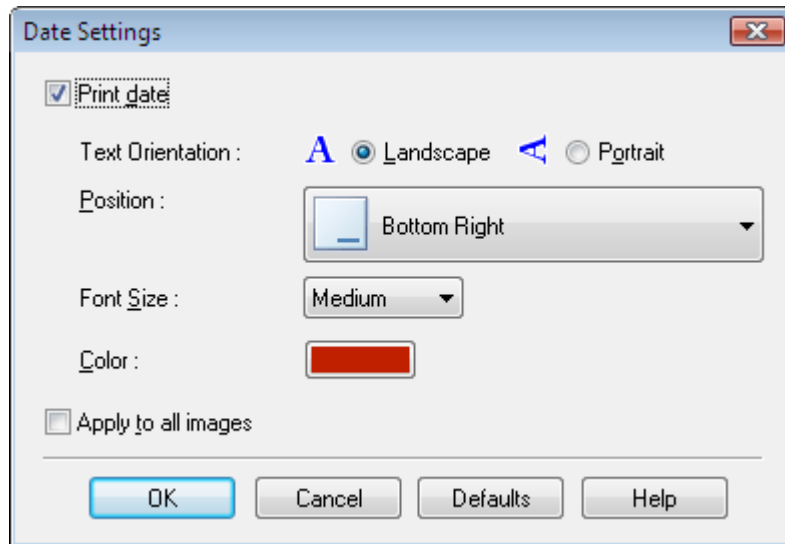

Note

- The date is displayed in the short date format (mm/dd/yyyy, etc.) specified in your operating system.
- See Help for details on setting dates.

Advanced Guide

Advanced Guide > Printing from a Computer > Printing with the Bundled Application Software > Photo Print Settings > Printing Multiple Photos on One Page



Printing Multiple Photos on One Page

You can print multiple photos on one page by selecting a multiple-photo layout in the Layout/Print screen.

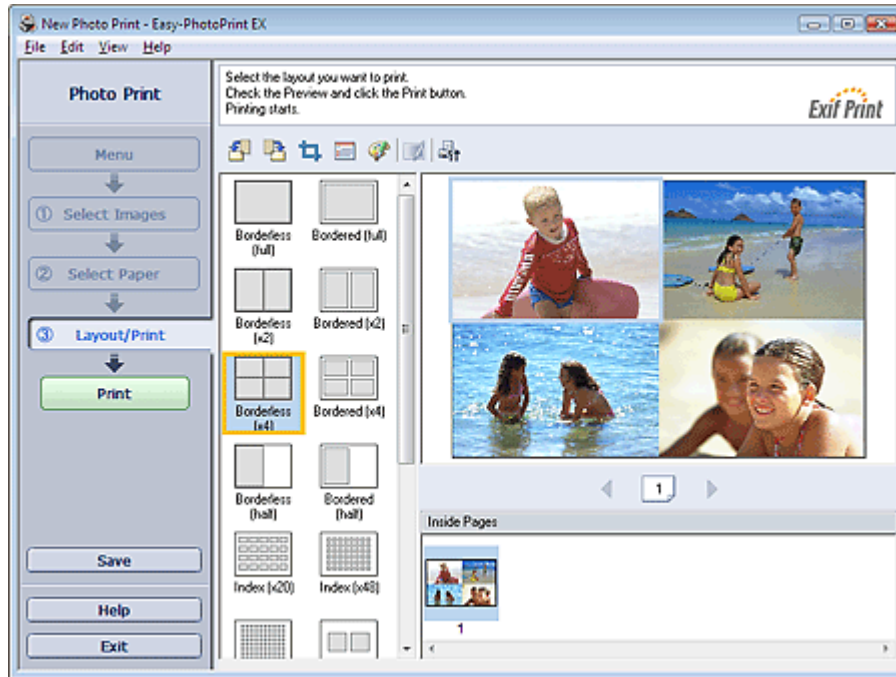

Note

- See the following section for details on how to select photos.
 ➔ **Selecting a Photo**
- The available number of photos and layout may vary depending on the media type.
- Photos are arranged in the following order.
 Example: Borderless (x4)

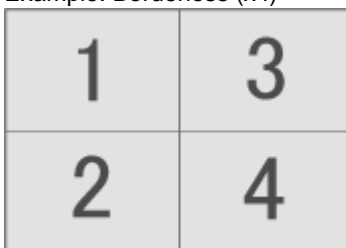

- You can change the printing order in Printing Order on the Print tab of the Preferences dialog box. You can select the printing order from By Date, By Name and By Selection.
 To display the Preferences dialog box, click (Settings) or select Preferences... from the File menu.

Advanced Guide

Advanced Guide > Printing from a Computer > Printing with the Bundled Application Software > Photo Print Settings > Printing an Index

Easy-PhotoPrint EX



Printing an Index

You can print an index of selected photos. An index print shows the thumbnails of the photos in one page. It is convenient for managing your photos.

To print an index, select Index from the layouts in the Layout/Print screen.

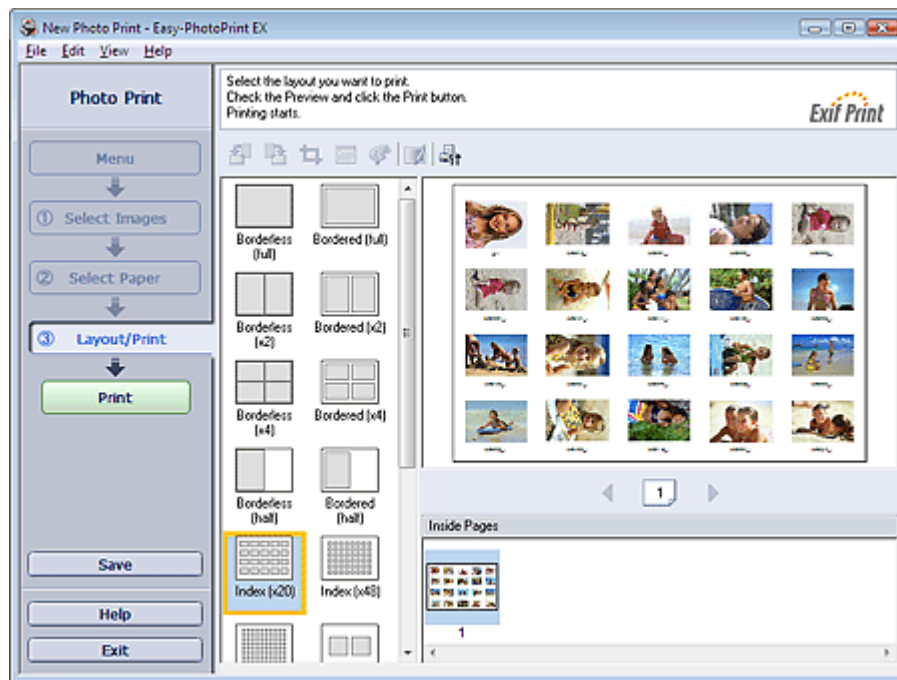

Important

- Index print will be disabled if you select any of the following paper sizes.
 - Credit Card
 - Fine Art A4
 - Fine Art A3
 - Fine Art A3+
 - Fine Art Letter
 - CD-R
- You can print up to 80 images on one page.

Note

- See the following section for details on how to select photos.
 - ➔ [Selecting a Photo](#)
- Photos are arranged in the following order.
Example: Index (x20)

1	2	3	4	5
6	7	8	9	10
11	12	13	14	15
16	17	18	19	20

- You can change the printing order in Printing Order on the Print tab of the Preferences dialog box. You can select the printing order from By Date, By Name, and By Selection.

To display the Preferences dialog box, click  (Settings) or select Preferences... from the File menu.

Advanced Guide

Advanced Guide > Printing from a Computer > Printing with the Bundled Application Software > Photo Print Settings > Printing ID Photos (ID Photo Print)

Easy-PhotoPrint EX



Printing ID Photos (ID Photo Print)

You can print a variety of ID photos.

Important

- The photo may not qualify as an official ID photo depending on its use. For details, contact the party to whom you will be submitting the photo.

To print ID photos, select 4"x6" 10x15cm for Paper Size in the Select Paper screen, and select a layout of the ID photo from the layouts in the Layout/Print screen.

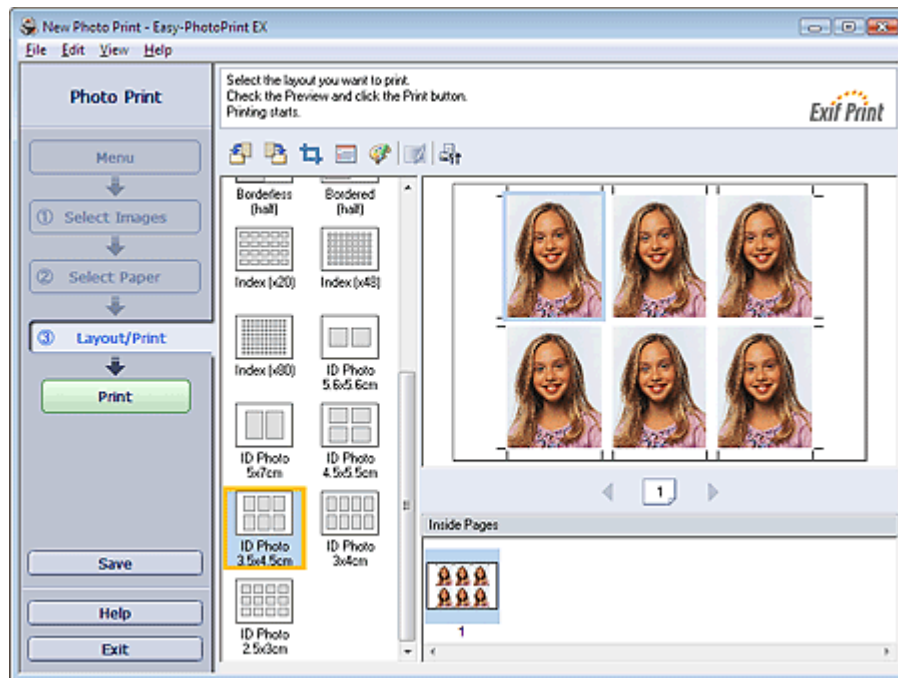

Note

- See the following section for details on how to select photos.

➔ [Selecting a Photo](#)

- Photos are arranged in the following order.

Example: ID Photo 3.5x4.5cm

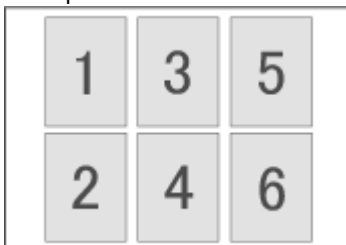

- You can change the printing order in Printing Order on the Print tab of the Preferences dialog box. You can select the printing order from By Date, By Name, and By Selection.

To display the Preferences dialog box, click  (Settings) or select Preferences... from the File menu.

Advanced Guide

Advanced Guide > Printing from a Computer > Printing with the Bundled Application Software > Photo Print Settings > Printing Photo Information

Easy-PhotoPrint EX



Printing Photo Information

Select Captured Info from the layouts in the Layout/Print screen to print the photo and the Exif information side by side.

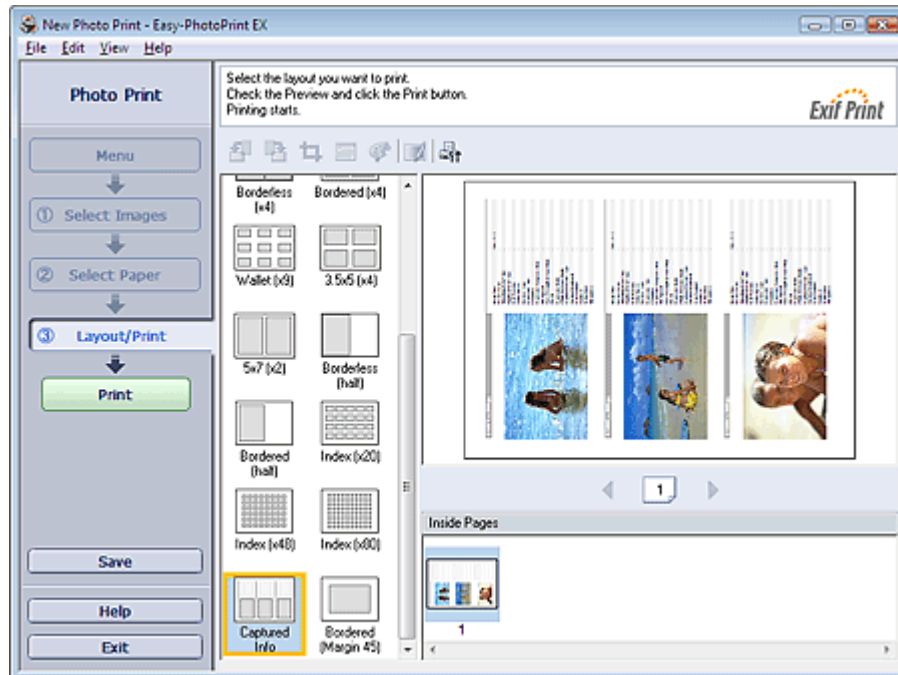

Note

- See the following section for details on how to select photos.
 - ➔ [Selecting a Photo](#)
- This function is available only on paper sizes Letter 8.5"x11" and A4.

[Page top](#)↑

Advanced Guide

Advanced Guide > Printing from a Computer > Printing with the Bundled Application Software > Photo Print Settings > Saving Photos

Easy-PhotoPrint EX



Saving Photos

You can save edited photos. The information of cropping and layout can be saved.

Click Save in the Layout/Print screen.

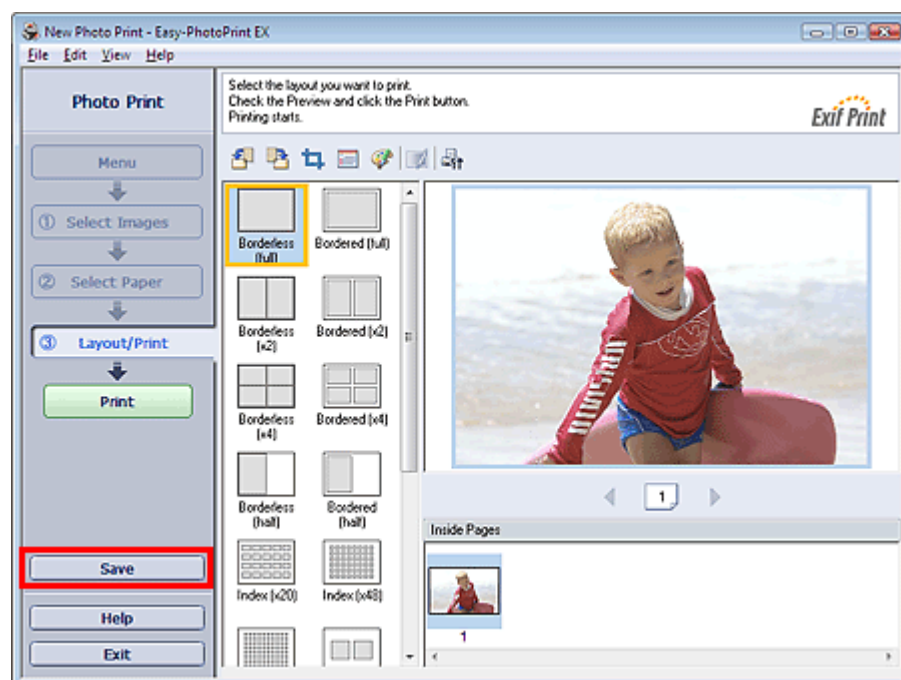

When the Save As dialog box appears, specify the save location and file name, then click Save.

Important

- If you edit a saved file and save it again, the file will be overwritten. To save a file again with a new name or to a different location, select Save As... from the File menu and save.

Note

- Save will not be displayed in the Select Images or Select Paper screen.

[Page top](#)↑

Advanced Guide

Advanced Guide > Printing from a Computer > Printing with the Bundled Application Software > Photo Print Settings > Opening Saved Files

Easy-PhotoPrint EX



Opening Saved Files

You can open files created with Easy-PhotoPrint EX.

1. Click Library from Menu.

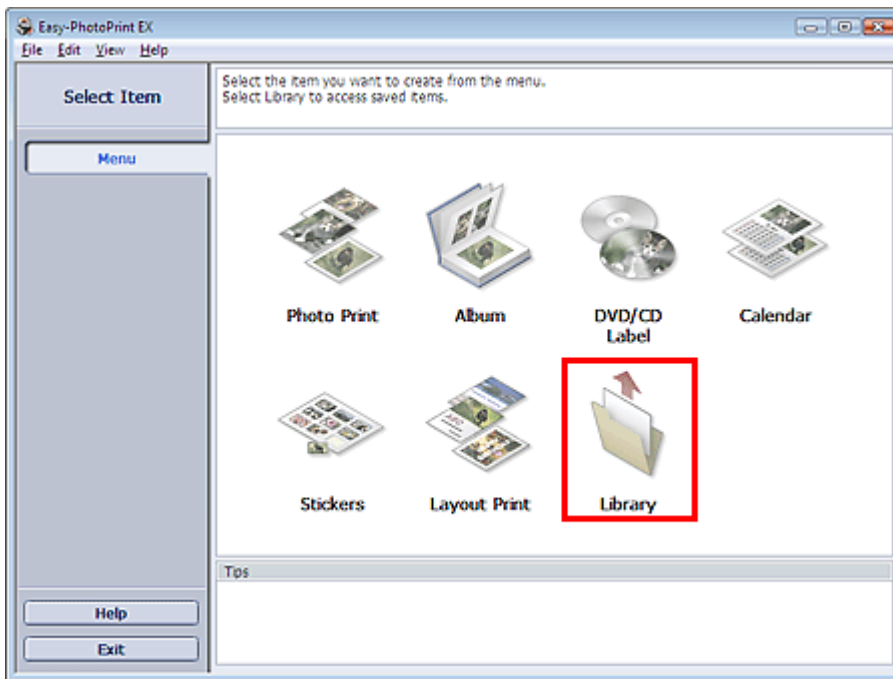

The Open dialog box appears.

You can check files created and saved with Easy-PhotoPrint EX by icon view (only for Windows Vista) or thumbnail view.

Important

- When using 64bit Edition of Windows Vista or Windows XP, the contents of files cannot be displayed on Explorer.

2. Select the file you want to open and click Open.

The Layout/Print screen appears.

Note

- Easy-PhotoPrint EX supports the following file format (extension).
 - Easy-PhotoPrint EX Photo Print file (.el6)

3. Edit the file if necessary.

Note

- You can open files created with Easy-PhotoPrint EX with the following methods, besides from Library in Menu.
 - Double-click or click the file.
 - From the File menu, click Open..., then select the file you want to edit.
- You can also open a recently used file by clicking the file name shown in the File menu.

Advanced Guide

Advanced Guide > Printing from a Computer > Printing with the Bundled Application Software > Other Settings

Easy-PhotoPrint EX

Other Settings

- Changing Layout
- Changing Background
- Adding Photos
- Swapping Positions of Photos
- Replacing Photos
- Changing Position, Angle and Size of Photos
- Cropping Photos
- Framing Photos
- Printing Dates on Photos
- Attaching Comments to Photos
- Adding Text to Photos
- Saving
- Setting Holidays
- Setting Calendar Display
- Opening Saved Files

[Page top](#)↑

Advanced Guide

Advanced Guide > Printing from a Computer > Printing with the Bundled Application Software > Other Settings > Changing Layout

Easy-PhotoPrint EX



Changing Layout

You can change the layout of each page separately.

Select the page you want to change the layout of in the Edit screen, then click  (Change Layout).
Select the layout you want to use in the Change Layout dialog box and click OK.

Album

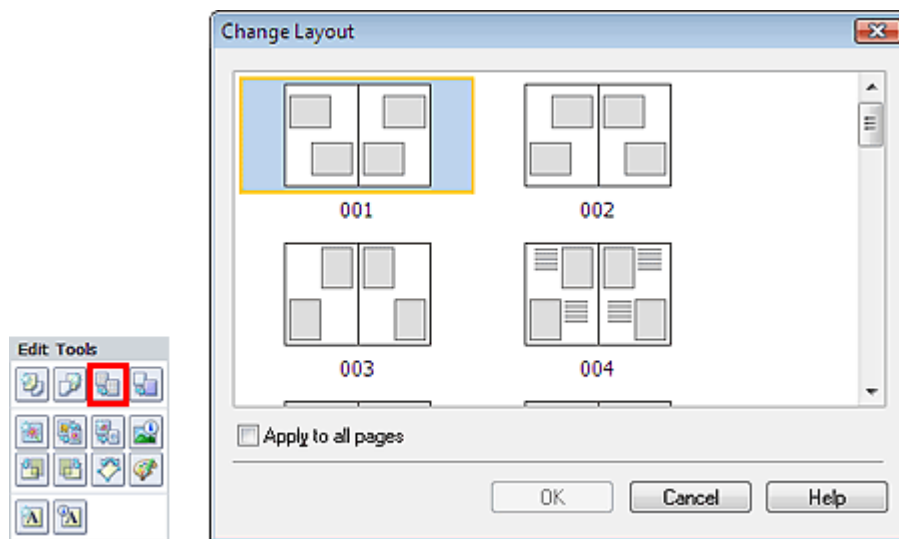

Important

- If the new layout has a different number of frames per page from the current layout, the following will happen:

If the number of layout frames is increased	: Images will move from the subsequent pages to fill all the frames in the new layout.
If the number of layout frames is decreased	: Pages with the new layout will be added until all the images on the pages with the current layout can be fitted.
- If you change the current layout for the front or back cover to one that has fewer layout frames, any image that does not fit in the new layout will be deleted, starting with the last image that was added to the former layout page.

Note

- The layouts that can be selected may vary depending on the Paper Size, Orientation, or the type of page selected (front cover, inside pages or back cover).
- Select the Apply to all pages checkbox to change the layouts of all pages to the one you newly selected.

Calendar

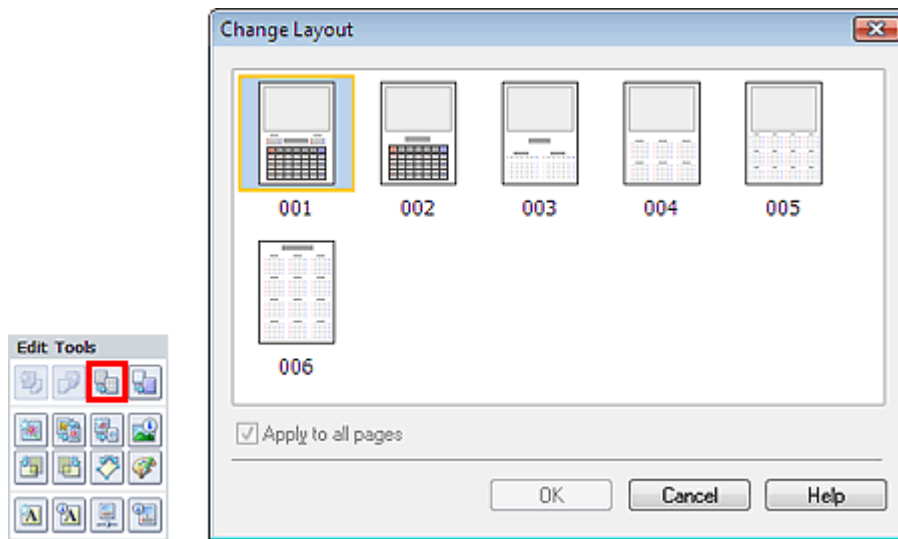

Important

- The layouts of all pages are changed to the selected layout.
- All images that do not fit in the new layout will be collected on the last page.

Note

- The layouts that can be selected may vary depending on the Paper Size and Orientation.

Layout Print

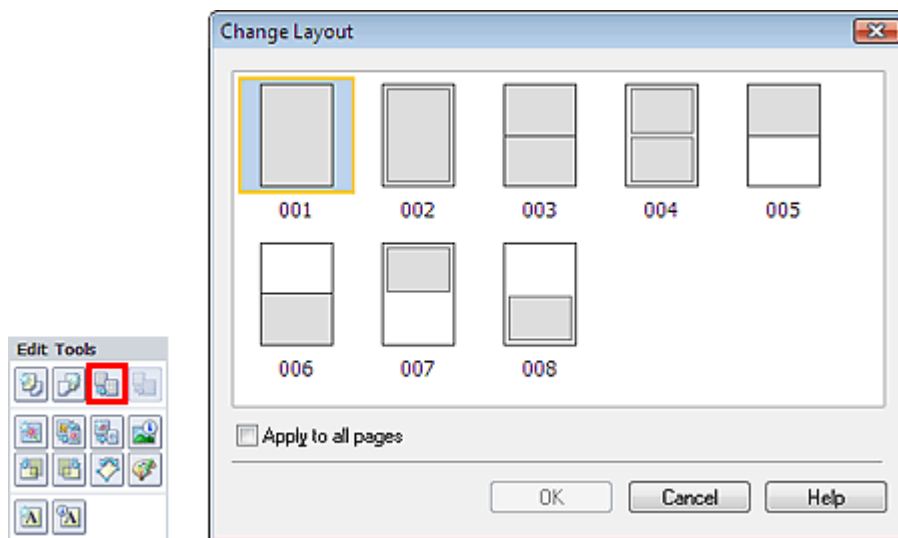

Important

- If the new layout has a different number of frames per page from the current layout, the following will happen:
 - If the number of layout frames is increased : Images will move from the subsequent pages to fill all the frames in the new layout.
 - If the number of layout frames is decreased : Pages with the new layout will be added until all the images on the pages with the current layout can be fitted.

Note

- The layouts that can be selected may vary depending on the Paper Size and Orientation.
- Select the Apply to all pages checkbox to change the layouts of all pages to the one you newly selected.

Advanced Guide

Advanced Guide > Printing from a Computer > Printing with the Bundled Application Software > Other Settings > Changing Background

Easy-PhotoPrint EX



Changing Background

You can change the background of each page.

Important

- You cannot change the background of the Photo Print, Stickers, and Layout Print.

Click Background... in the Page Setup screen or select the page you want to change the background of in

the Edit screen, then click  (Change Background).

Note

- The screens for Album printing are used as examples in the following descriptions. The screens may vary depending on what you create.

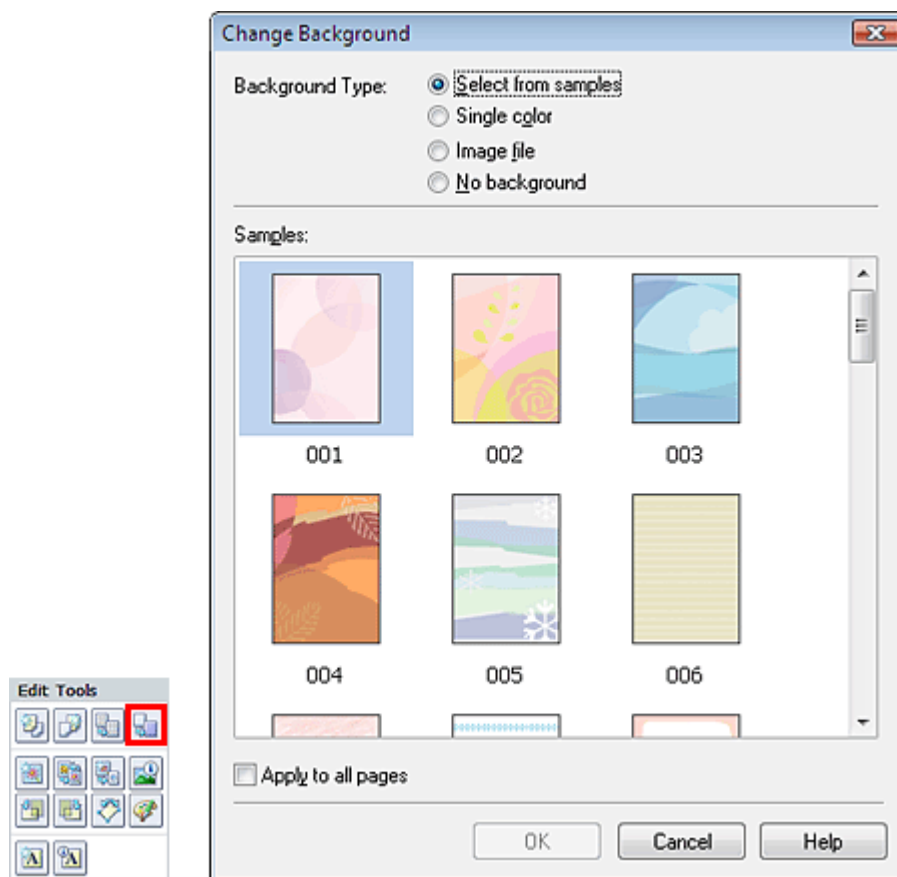

Select the type of background you want to use in the Change Background dialog box.

When Select from samples is Selected

Select the image you want to use from Samples and click OK.

Note

- Select from samples will be displayed only if Album has been selected.

When Single color is Selected

Select the color you want to use from Standard color or Custom color and click OK.

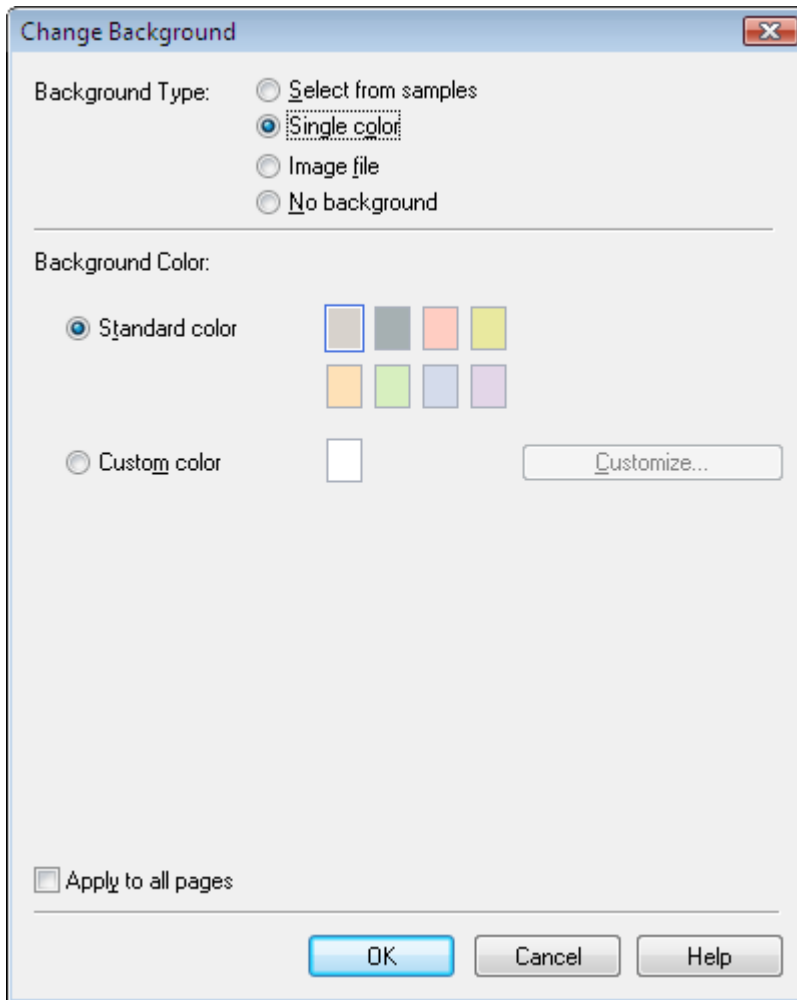

When Image file is Selected

Set Image File Path and Image Layout, then click OK.

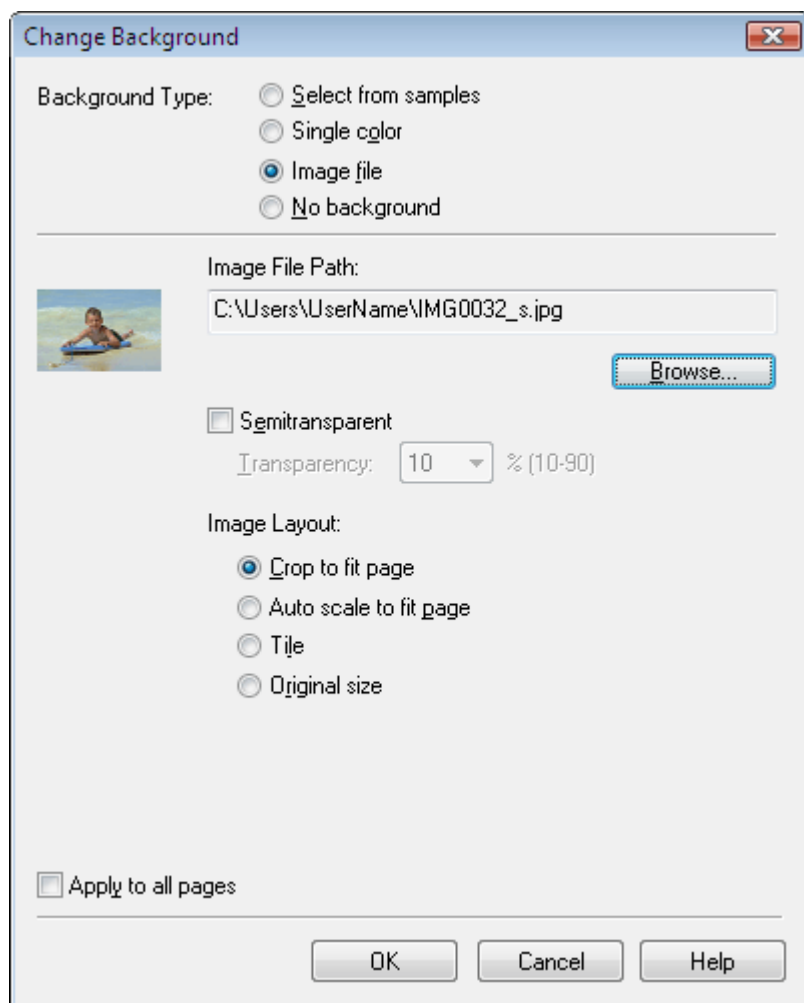

Note

- See Help for details on how to set the background in the Change Background dialog box.

Advanced Guide

Advanced Guide > Printing from a Computer > Printing with the Bundled Application Software > Other Settings > Adding Photos

Easy-PhotoPrint EX



Adding Photos

You can add images to pages.

Select the page you want to add photos in the Edit screen, then click  (Add Image).

Note

- The screens for Album printing are used as examples in the following descriptions. The screens may vary depending on what you create.

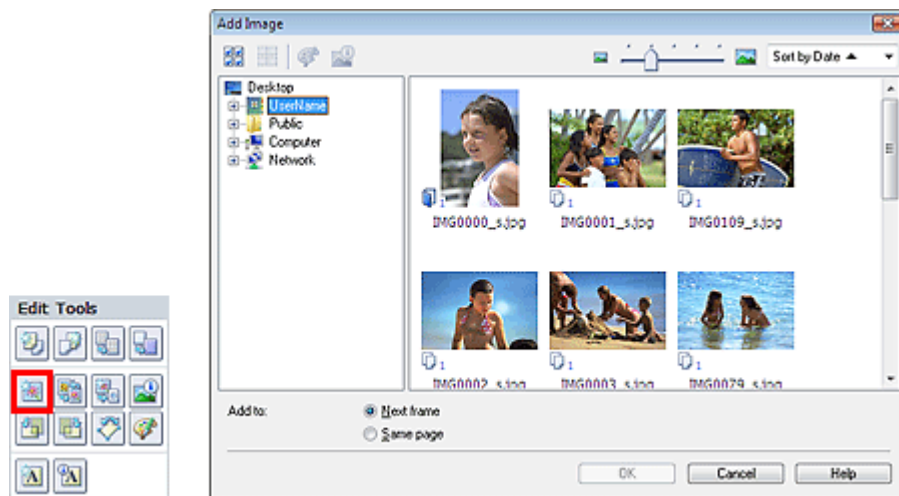

Select the folder containing the image you want to add from the folder tree area on the left of the Add Image dialog box, and select the image you want to add from the thumbnail window on the right.

Note

- Click an image to select it (background turns blue) or deselect it (background turns white). You can also select multiple images.

Select an option for Add to and click OK.

Important

- You can add up to 20 images at one time to a single page.
- Up to 99 of the same images can be added to all pages combined.
- You cannot add two or more of the same image at one time. Add it one at a time.
- When the number of pages increases due to added images, you cannot add images beyond page 400.

Note

- In the Add Image dialog box, you can select all images at one time or change the display size and order of the thumbnails. See Help for details.

Advanced Guide

Advanced Guide > Printing from a Computer > Printing with the Bundled Application Software > Other Settings > Swapping Positions of Photos

Easy-PhotoPrint EX



Swapping Positions of Photos

You can swap the positions of images.



Click  (Swap Image Positions) in the Edit screen.

Note

- The screens for Album printing are used as examples in the following descriptions. The screens may vary depending on what you create.



Select the target and source images you want to swap, then click Swap.

When you finish swapping all images you want to swap, click Back to Edit.

[Page top](#)↑

Advanced Guide

Advanced Guide > Printing from a Computer > Printing with the Bundled Application Software > Other Settings > Replacing Photos

Easy-PhotoPrint EX



Replacing Photos

You can replace an image with another image.

Select the image you want to replace in the Edit screen, then click  (Replace Selected Image).

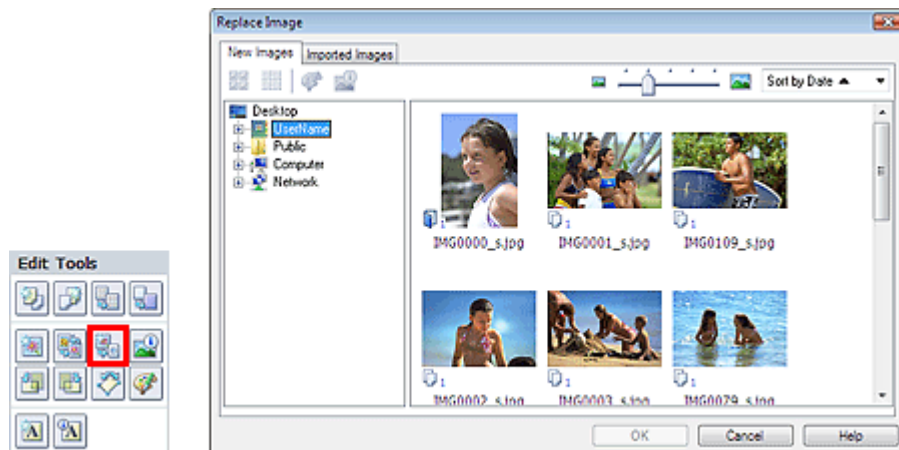

Select the folder containing the image you want to replace with from the folder tree area on the left of the Replace Image dialog box.

Select the image you want to replace with from the thumbnail window on the right of the screen and click OK.

If you want to select from the images already imported, click the Imported Images tab and select the image you want to replace with from the thumbnail window and click OK.

Important

- You cannot select multiple images in the Replace Image dialog box.

Note

- If you select multiple images in the Edit screen and use the replacement function, all the images selected in the Edit screen will be replaced with the image selected in the Replace Image dialog box.
- When images are replaced, the following settings of the old image are inherited to the new image.
 - Position
 - Size
 - Frame
 - Position and size of the date
 The cropping information and image orientation are not inherited.
- In the Replace Image dialog box, you can change the display size and order of the thumbnails. See Help for details.

Advanced Guide

Advanced Guide > Printing from a Computer > Printing with the Bundled Application Software > Other Settings > Changing Position, Angle and Size of Photos

Easy-PhotoPrint EX



Changing Position, Angle and Size of Photos

You can adjust the position, angle and size of images.

Select the image of which you want to change the position or size in the Edit screen and click  (Edit Image) or double-click the image.

Edit Image

Position & Size | Crop | Frame | Date | Comments

File Name: IMG0032_s.jpg

Center Position:

From Left of Page: 74.2 mm From Top of Page: 81.7 mm

Rotation: 0.0 °

Size:

Custom size

Lock aspect ratio

Width: 118.5 mm Height: 79.0 mm

Standard size

Size: 4"x6"

OK Cancel Help

Set the Center Position, Rotation and Size, then click OK.

Note

- You can also change the position and size of an image by dragging it in the Edit screen.
- Select an image in the Edit screen, then click  (Free Rotate) and drag a corner of the image to rotate it.
- See Help for details on the position and size of images.

[Page top↑](#)

Advanced Guide

Advanced Guide > Printing from a Computer > Printing with the Bundled Application Software > Other Settings > Cropping Photos

Easy-PhotoPrint EX



Cropping Photos

Cropping an image is the act of removing the unnecessary portions of the image by selecting the necessary portions.

Select the image you want to crop in the Edit screen and click  (Edit Image) or double-click the image.

Click the Crop tab in the Edit Image dialog box.

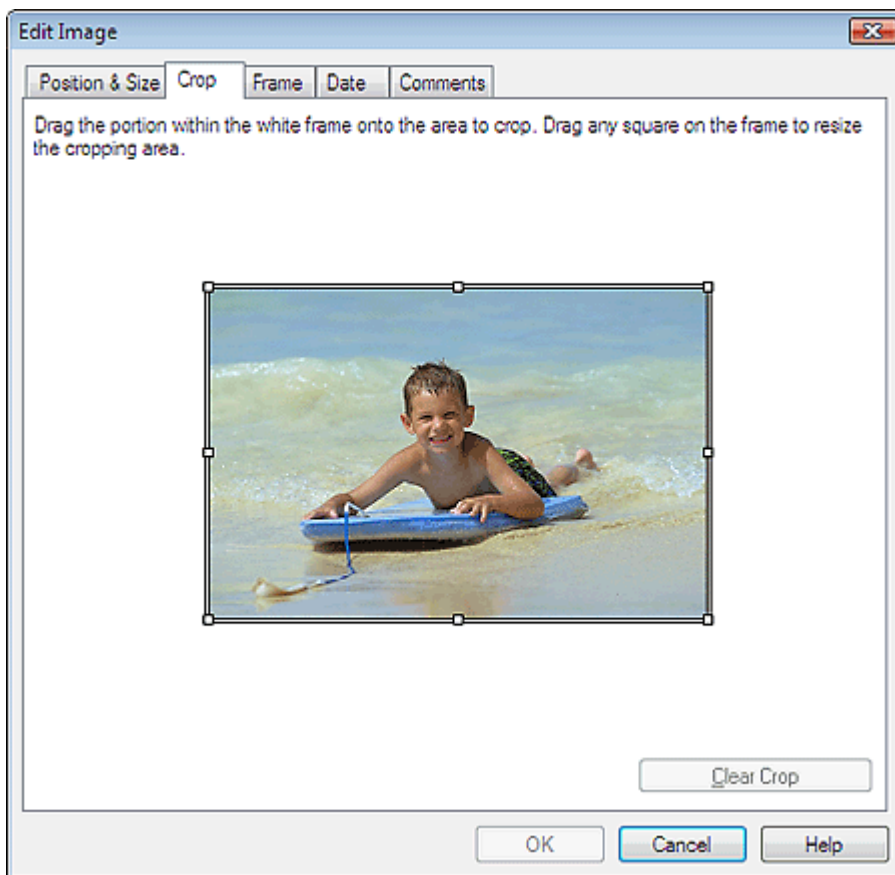

Drag the white squares on the image to change the area to be cropped and click OK.

Note

- See Help for details on cropping.

Advanced Guide

Advanced Guide > Printing from a Computer > Printing with the Bundled Application Software > Other Settings > Framing Photos

Easy-PhotoPrint EX



Framing Photos

You can add frames to images.

Important

- You cannot add frames to images in Photo Print, Stickers, and Layout Print.



Select the image you want to frame in the Edit screen and click  (Edit Image) or double-click the image.

Click the Frame tab in the Edit Image dialog box.

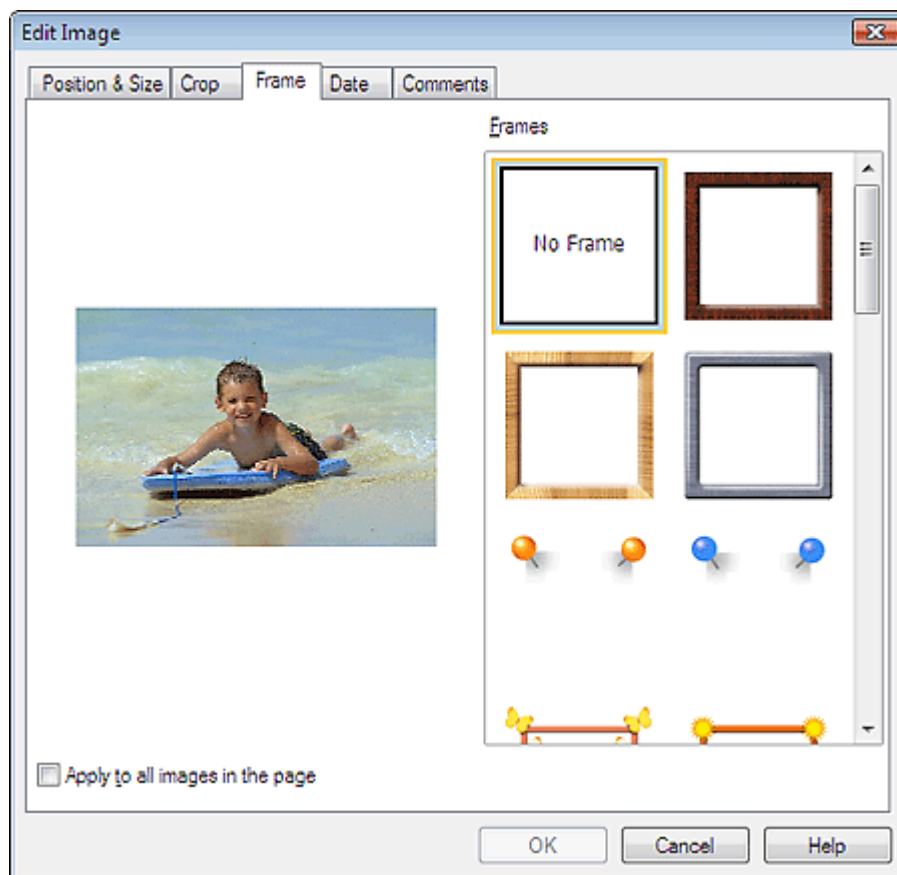

Select the frame you want to use from Frames and click OK.

Important

- You cannot print dates on framed photos.

Note

- Select the Apply to all images in the page checkbox to add the same frame to all the images on a selected page at one time.
- See Help for details on frames.

Advanced Guide

Advanced Guide > Printing from a Computer > Printing with the Bundled Application Software > Other Settings > Printing Dates on Photos

Easy-PhotoPrint EX



Printing Dates on Photos

You can print dates on images.

Select the image you want to print the date in the Edit screen and click  (Edit Image) or double-click the image.

Click the Date tab in the Edit Image dialog box.

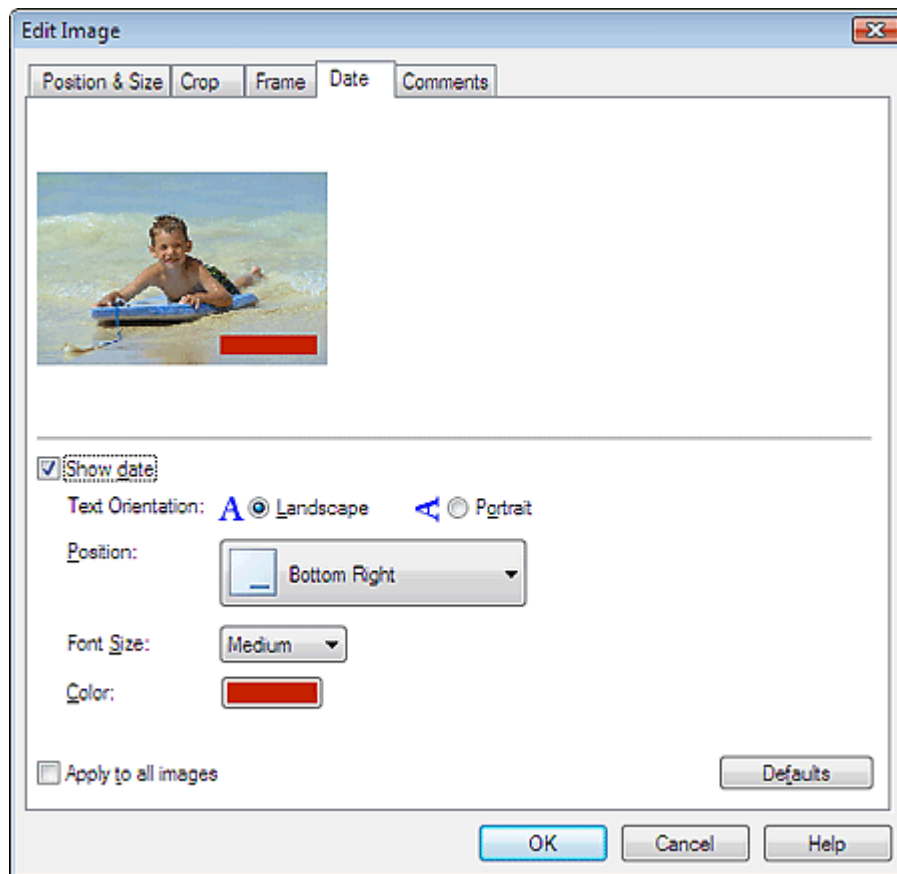

Select the Show date checkbox.

Set the Text Orientation, Position, Font Size and Color, then click OK.

Important

- You cannot print dates on framed images.

Note

- The date is displayed in the short date format (mm/dd/yyyy, etc.) specified in your operating system.
- See Help for details on setting dates.

Advanced Guide

Advanced Guide > Printing from a Computer > Printing with the Bundled Application Software > Other Settings > Attaching Comments to Photos

Easy-PhotoPrint EX



Attaching Comments to Photos

You can attach comments to images and display them in your album. The photo name, shooting date and comments are displayed (from top to bottom) in a comment box.



Important

- You cannot attach comments to Photo Print, Calendar, Stickers, and Layout Print.

Select the image you want to attach comments to in the Edit screen and click  (Edit Image) or double-click the image.

Click the Comments tab in the Edit Image dialog box.

Select the Show comment box checkbox.

Select the checkboxes of the items you want to display, and enter comments.

Set the size and color of font, and position of the comments, etc., then click OK.

 **Note**

- See Help for details on comments.
-

[Page top](#)↑

Advanced Guide

Advanced Guide > Printing from a Computer > Printing with the Bundled Application Software > Other Settings > Adding Text to Photos

Easy-PhotoPrint EX



Adding Text to Photos

You can add text to photos.

Click  (Add Text) in the Edit screen and drag the mouse over the area in which you want to add text.

Note

- The screens for Album printing are used as examples in the following descriptions. The screens may vary depending on what you create.

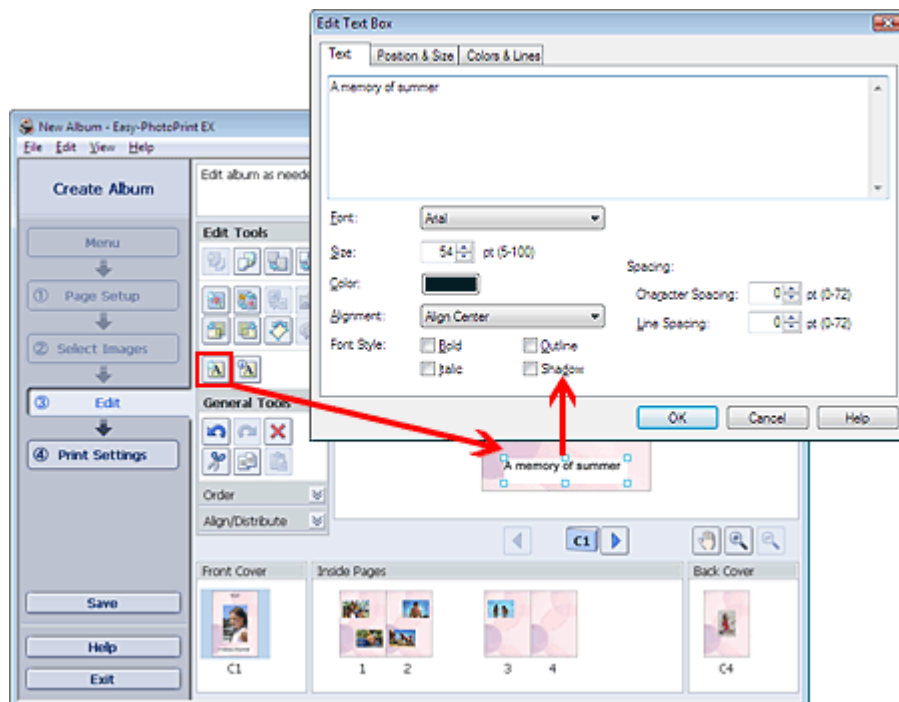

Select the Text tab in the Edit Text Box dialog box and enter text.

Note

- In the Edit Text Box dialog box, you can change the position, angle and size of the text. You can also set the color and line of the text box. See Help for details.
- To change the entered text, select it and click  (Edit Text Box). The Edit Text Box dialog box appears. You can change the text.

Advanced Guide

Advanced Guide > Printing from a Computer > Printing with the Bundled Application Software > Other Settings > Saving

Easy-PhotoPrint EX



Saving

You can save edited items.

Click Save in the Edit or Print Settings screen.

Note

- The screens for Album printing are used as examples in the following descriptions. The screens may vary depending on what you create.

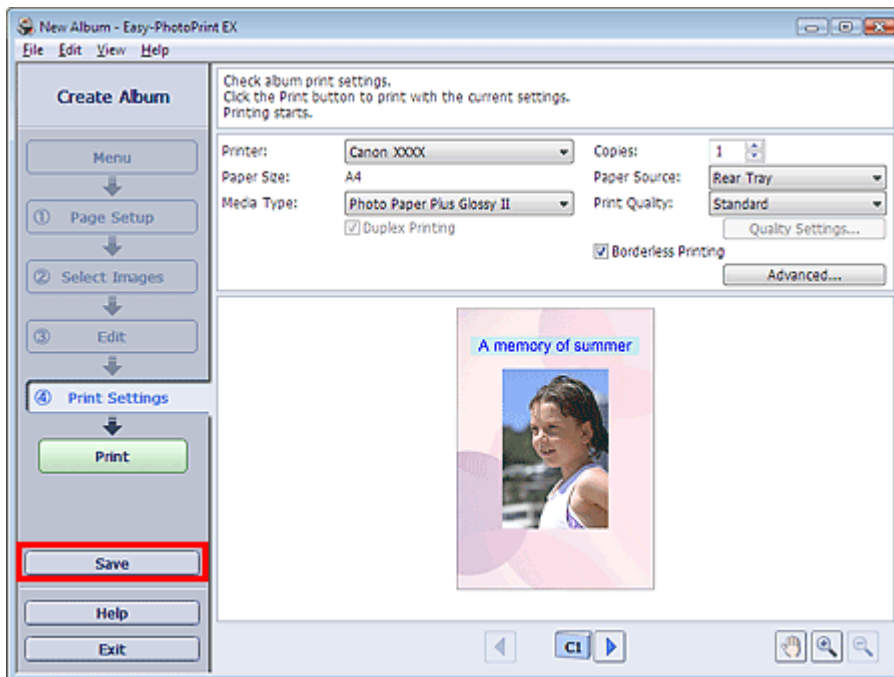

When the Save As dialog box appears, specify the save location and file name, then click Save.

Important

- If you edit a saved file and save it again, the file will be overwritten.
To save a file again with a new name or to a different location, select Save As... from the File menu and save.

Note

- Save will not be displayed in the Page Setup or Select Images screen.

[Page top](#)↑

Advanced Guide

Advanced Guide > Printing from a Computer > Printing with the Bundled Application Software > Other Settings > Setting Holidays

Easy-PhotoPrint EX



Setting Holidays

You can add holidays to your calendar.

Click Set Holidays... in the Page Setup screen of Calendar, or click  (Setup Period/Holiday) in the Edit screen and click Set Holidays... in the Calendar General Settings dialog box to display the Holiday Settings dialog box.

Date	Holiday Name	Set as Holiday

To add a holiday, click Add.... The Add/Edit Holiday dialog box appears. To edit a saved holiday, select it and click Edit....

To delete a holiday, select it and click Delete. To delete all the saved holidays within your calendar period, click Clear.

Enter the name in Holiday Name and specify the date.

Select the Set as Holiday checkbox to display that day as a holiday in your calendar.

 **Note**

- See Help for details on each dialog box.
-

[Page top](#)↑

Advanced Guide

Advanced Guide > Printing from a Computer > Printing with the Bundled Application Software > Other Settings > Setting Calendar Display

Easy-PhotoPrint EX



Setting Calendar Display

You can customize the calendar display (fonts, lines, colors, position, size, etc.).

Click Settings... in the Page Setup screen of Calendar, or select a calendar in the Edit screen and click



(Setup Calendar) to display the Calendar Settings dialog box.

Important

- The Position & Size tab is displayed only when the Calendar Settings dialog box is displayed from the Edit screen.

The screenshot shows the 'Calendar Settings' dialog box with the 'Position & Size' tab selected. On the left is a preview of a calendar for October 2009. The right side contains settings for three different styles:

- Style for Year and Month:** Font: Arial, Format: 10/2009
- Style for Days of Week:** Font: Arial, Week Starts on: Sunday
- Style for Days:** Font: Arial

At the bottom right of the dialog is a 'Defaults' button. At the bottom of the window are 'OK', 'Cancel', and 'Help' buttons.

Note

- See Help for details on the Calendar Settings dialog box.

Advanced Guide

Advanced Guide > Printing from a Computer > Printing with the Bundled Application Software > Other Settings > Opening Saved Files

Easy-PhotoPrint EX



Opening Saved Files

You can open files created with Easy-PhotoPrint EX.

1. Click Library from Menu.

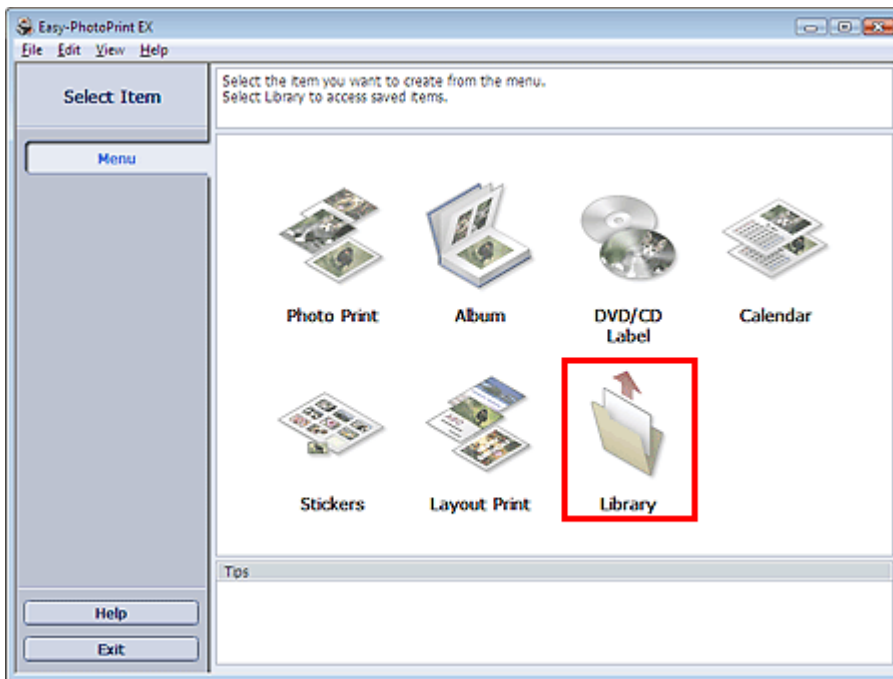

The Open dialog box appears.

You can check files created and saved with Easy-PhotoPrint EX by icon view (only for Windows Vista) or thumbnail view.

Important

- When using 64bit Edition of Windows Vista or Windows XP, the contents of files cannot be displayed on Explorer.

2. Select the file you want to open and click Open.

The Edit screen appears.

Note

- Easy-PhotoPrint EX supports the following file formats (extensions).
 - Easy-PhotoPrint EX Album file (.el1)
 - Easy-PhotoPrint EX Stickers file (.el2)
 - Easy-PhotoPrint EX Calendar file (.el4)
 - Easy-PhotoPrint EX Layout file (.el5)
 - CD-LabelPrint data (.cld)

3. Edit the file if necessary.

Note

- See the following sections for details on the editing procedures.
 - ➔ Editing Album
 - ➔ Editing Calendar
 - ➔ Editing Stickers
 - ➔ Editing Layout Print

 **Note**

-
- You can open files created with Easy-PhotoPrint EX with the following methods, besides from Library in Menu.
 - Double-click or click the file.
 - From the File menu, click Open..., then select the file you want to edit.
 - You can also open a recently used file by clicking the file name shown in the File menu.
-

[Page top](#)↑

Advanced Guide

Advanced Guide > Printing from a Computer > Printing with the Bundled Application Software > What Is Easy-PhotoPrint Pro?

Easy-PhotoPrint Pro

What Is Easy-PhotoPrint Pro?

Easy-PhotoPrint Pro is a plug-in for Adobe Photoshop and Digital Photo Professional, an application for Canon digital single-lens reflex cameras. Easy-PhotoPrint Pro allows you to print photos easily in various styles, including borderless full-page, index, grayscale, and Adobe RGB mode.



Important

- Easy-PhotoPrint Pro supports Adobe Photoshop CS, Photoshop CS2, Photoshop CS3 and Photoshop Elements 6, and Digital Photo Professional Ver.2.1 or later only. For updated compatibility, visit our website.
- Easy-PhotoPrint Pro does not support Windows 95, Windows 98, Windows Me, or Windows NT4.
- If a printer that supports Easy-PhotoPrint Pro is not installed, you cannot start Easy-PhotoPrint Pro.
- Although compatibility with Windows Vista and Windows XP has been confirmed, Easy-PhotoPrint Pro does not support the Fast User Switching feature of Windows Vista and Windows XP. It is recommended that you exit Easy-PhotoPrint Pro before using Fast User Switching.
- If Adobe Photoshop is installed after installing Easy-PhotoPrint Pro, you cannot start Easy-PhotoPrint Pro as it does not appear in Adobe Photoshop's menu. In that case, follow these steps to install the Photoshop Plug-In.
 1. From the Start menu, select (All) Programs > Canon Utilities > Easy-PhotoPrint Pro > Photoshop Plug-In Installer.
 2. Follow the on-screen instructions to install.

Note

- See Help of Easy-PhotoPrint Pro for descriptions of Easy-PhotoPrint Pro screens. Click Help in a dialog box, or select Help Topics from the Help menu. Help appears.
- In Windows Vista, using the XPS printer driver enables you to print in the High Dynamic Range (full 16-bit workflow). See "[XPS Printer Driver](#)" for details on the XPS printer driver.

Supported Data Formats

- One color (8 or 16 bits) per pixel RGB data formats supported by Adobe Photoshop
- One color (8 or 16 bits) per pixel RGB data formats supported by Digital Photo Professional

General Note

- The color tone of the image displayed on the display (monitor) is different from the print result.

[Page top](#)↑

Advanced Guide

Advanced Guide > Printing from a Computer > Printing with the Bundled Application Software > Printing Beautiful Photos

Easy-PhotoPrint Pro

Printing Beautiful Photos

Easy-PhotoPrint Pro allows you to print images captured in Adobe RGB or sRGB mode, in colors that are close to their original colors by using ICC profiles. You can also print with Canon's unique color tones (Canon Digital Photo Color) or print edited/retouched sRGB images in the edited/retouched state.

By applying the suitable printing method, you can produce photos that meet your expectations.

The diagram below shows the flow of digital imaging from importing captured photo into Adobe Photoshop or Digital Photo Professional to printing.

Operation varies depending on the purpose. Check the operational flow in the following diagram.

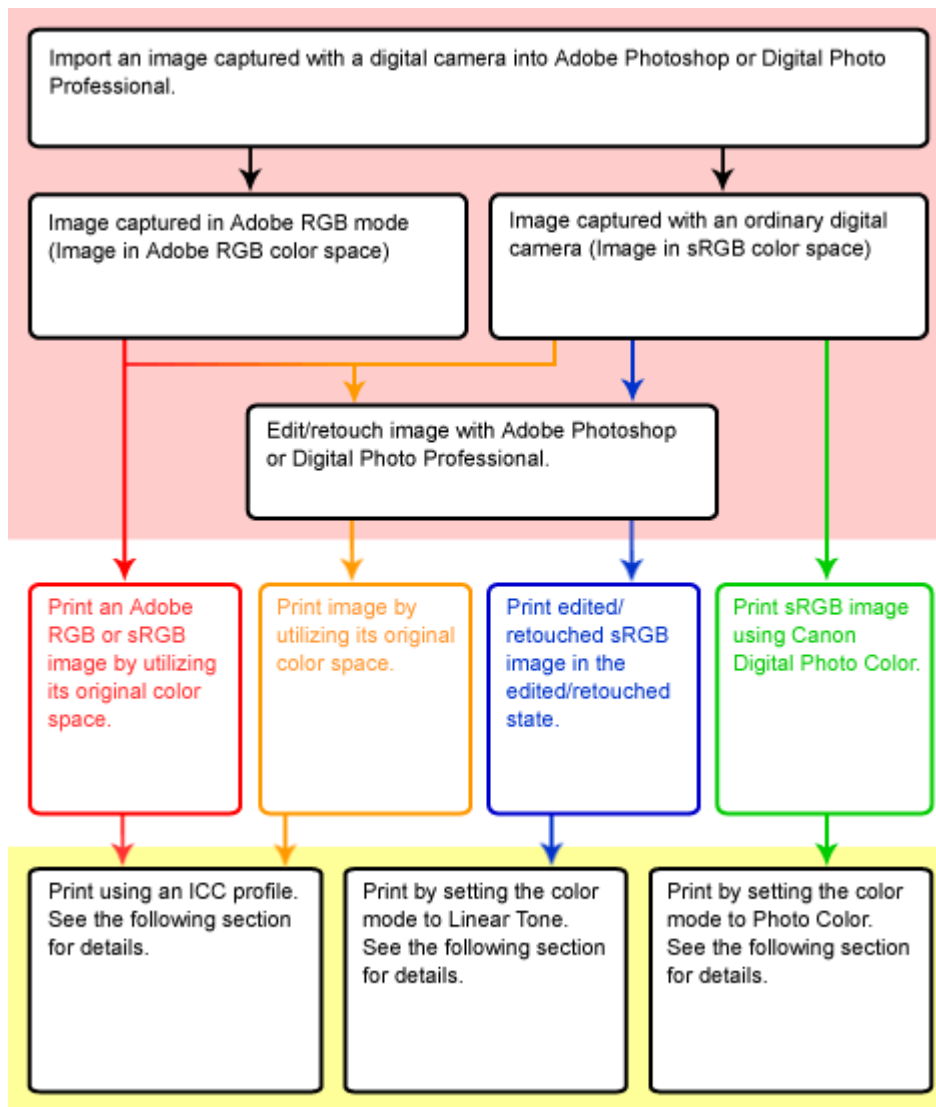

: Operations with Adobe Photoshop or Digital Photo Professional
 : Operations with Easy-PhotoPrint Pro

Detailed Operations

- : Printing an Adobe RGB or sRGB image by utilizing its original color space
- : Printing an image by utilizing its original color space
 - ➡ Printing with ICC Profiles (Adobe RGB, sRGB)
- : Printing an edited/retouched sRGB image in the edited/retouched state
 - ➡ Printing Edited/Retouched sRGB Images

- ➔ : Printing an sRGB image using Canon Digital Photo Color
 - ➔ Printing with Canon's Unique Color Tones

Note

- Colors in prints look different depending on the lighting conditions. To prevent such differences, you can correct images and print in color tones suitable for their corresponding light sources.
 - ➔ [Printing According to the Lighting in the Viewing Environment](#)
-

Color Management Terms

- **What is an ICC Profile?**

ICC profile is a data file that describes the color reproduction characteristics of individual devices to match the colors between input devices (scanners and digital cameras) and output devices (displays and printers).

- **What is sRGB?**

sRGB is an international standard color space, developed for the purpose of unifying the colors of digital cameras and displays.

- **What is Adobe RGB?**

Adobe RGB is a color space (which defines the range of colors) that is larger than sRGB. In printing, Adobe RGB can represent the range of colors between green and cyan that cannot be represented by sRGB.

- **What is Canon Digital Photo Color?**

Canon Digital Photo Color is Canon's unique image processing technology. This technology allows you to print images in popular, beautiful color tones by producing high contrast with sharp, three-dimensional feel while reproducing the genuine colors of the original image.

[Page top](#)↑

Advanced Guide

Advanced Guide > Printing from a Computer > Printing with the Bundled Application Software > Printing Beautiful Photos > Printing with ICC Profiles (Adobe RGB, sRGB)

Easy-PhotoPrint Pro

Printing with ICC Profiles (Adobe RGB, sRGB)

By specifying an ICC profile, you can print an image captured in Adobe RGB or sRGB mode by utilizing its original color space, or print in colors that are close to those corrected with Adobe Photoshop or Digital Photo Professional.

1. Start Easy-PhotoPrint Pro and select the photo you want to print.

The photo appears in the bottom right area of the screen.

Note

- See "Selecting a Photo" for details on how to select photos.

2. In the Printer Settings window, click Color Adjustment....

The Color Adjustment dialog box appears.

3. Click the Color Management tab.

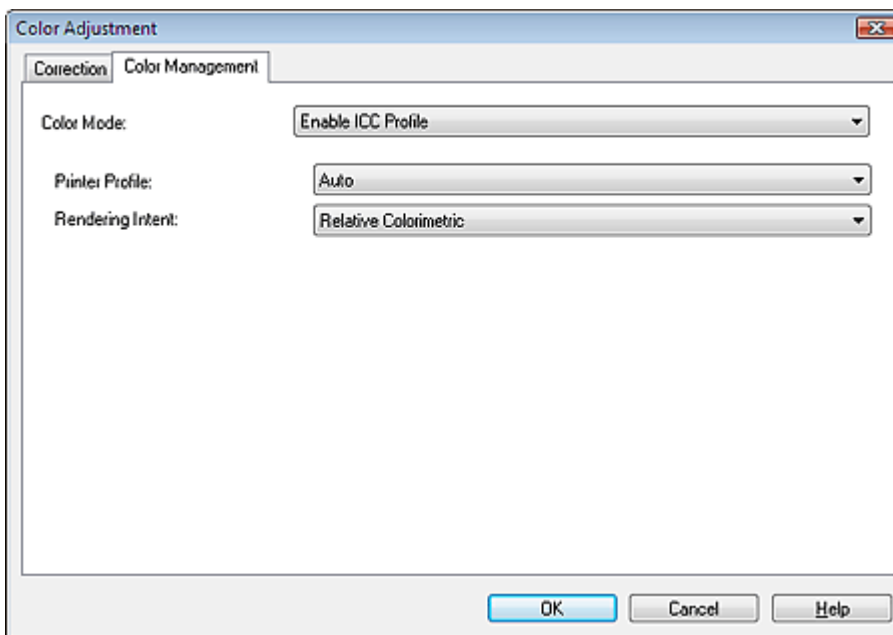

4. Select Enable ICC Profile for Color Mode.

5. Select Auto for Printer Profile.

Note

- For Auto, the most suitable profile is selected automatically based on the selected printer, paper and print quality.
- You can also select a specific ICC profile.

6. Select the desired matching method from Rendering Intent.

Note

- Relative Colorimetric: Converts the image to the printer color space in a way that the source colors within the color gamut of the target space are reproduced to the nearest level. Select this when you want to print in colors that are close to the original image.
- Perceptual: Reproduces the image focusing on the use of popular color tones. Select this

when you want to print the photo.

7. Click OK.

8. Click Print.

The Print dialog box appears.

9. Click OK.

 **Note**

- You can also change the color balance, brightness and contrast of the image.
 - ➔ Adjusting the Color Balance
 - ➔ Adjusting Brightness/Contrast
-

[Page top](#)↑

Advanced Guide

Advanced Guide > Printing from a Computer > Printing with the Bundled Application Software > Printing Beautiful Photos > Printing Edited/Retouched sRGB Images

Easy-PhotoPrint Pro

Printing Edited/Retouched sRGB Images

You can print edited/retouched sRGB images in the edited/retouched state.

Important

- You may not be able to print with this setting depending on the printer type.

1. Start Easy-PhotoPrint Pro and select the photo you want to print.

The photo appears in the bottom right area of the screen.

Note

- See "[Selecting a Photo](#)" for details on how to select photos.

2. In the Printer Settings window, click Color Adjustment....

The Color Adjustment dialog box appears.

3. Click the Color Management tab.

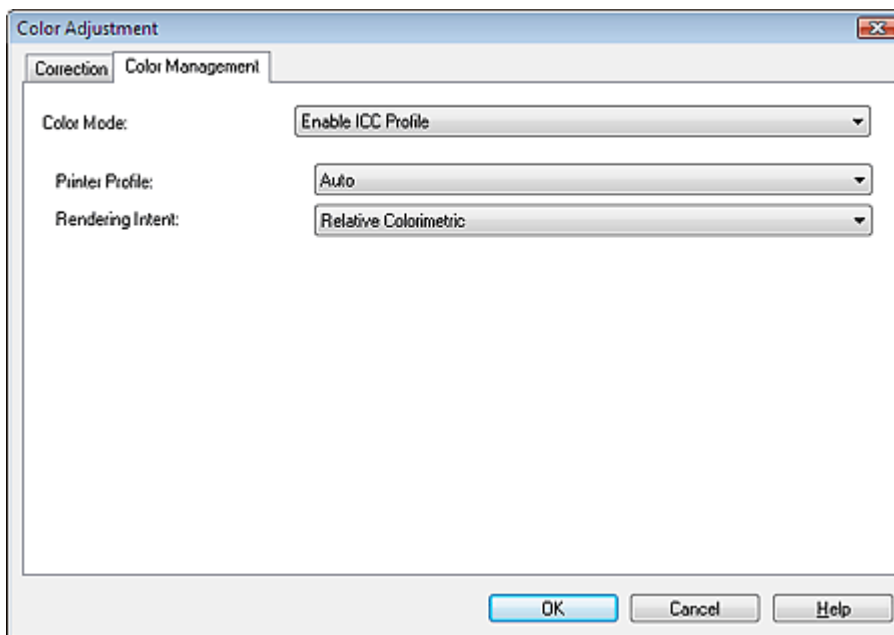

4. Select Linear Tone for Color Mode.

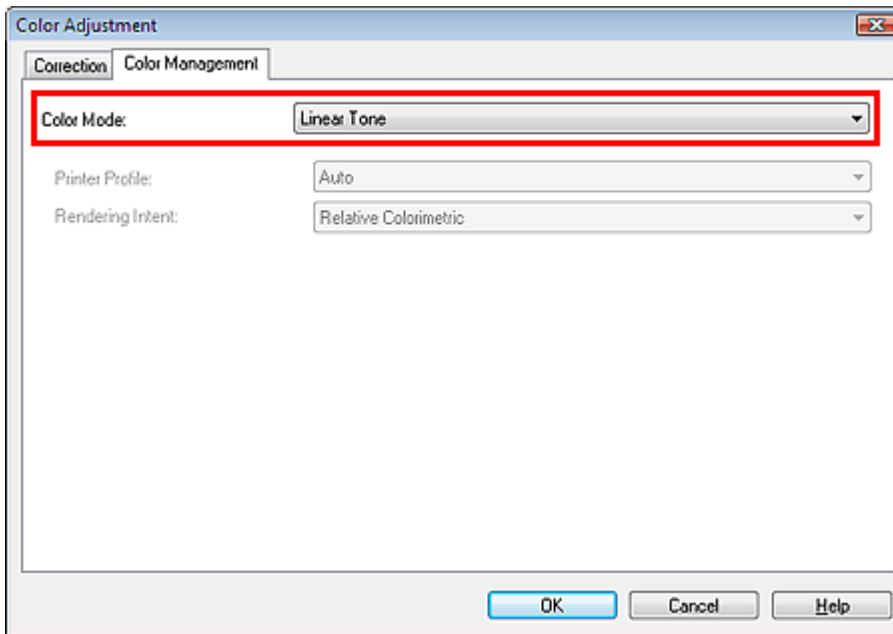

5. Click OK.

6. Click Print.

The Print dialog box appears.

7. Click OK.

Note

- You can also change the color balance, brightness and contrast of the image.
 - ➔ Adjusting the Color Balance
 - ➔ Adjusting Brightness/Contrast

Advanced Guide

Advanced Guide > Printing from a Computer > Printing with the Bundled Application Software > Printing Beautiful Photos > Printing with Canon's Unique Color Tones

Easy-PhotoPrint Pro

Printing with Canon's Unique Color Tones

You can print sRGB images using Canon Digital Photo Color.

Note

- Canon Digital Photo Color is Canon's unique image processing technology. This technology allows you to print images in popular, beautiful color tones by producing high contrast with sharp, three-dimensional feel while reproducing the genuine colors of the original image.

1. Start Easy-PhotoPrint Pro and select the photo you want to print.

The photo appears in the bottom right area of the screen.

Note

- See "[Selecting a Photo](#)" for details on how to select photos.

2. In the Printer Settings window, click Color Adjustment....

The Color Adjustment dialog box appears.

3. Click the Color Management tab.

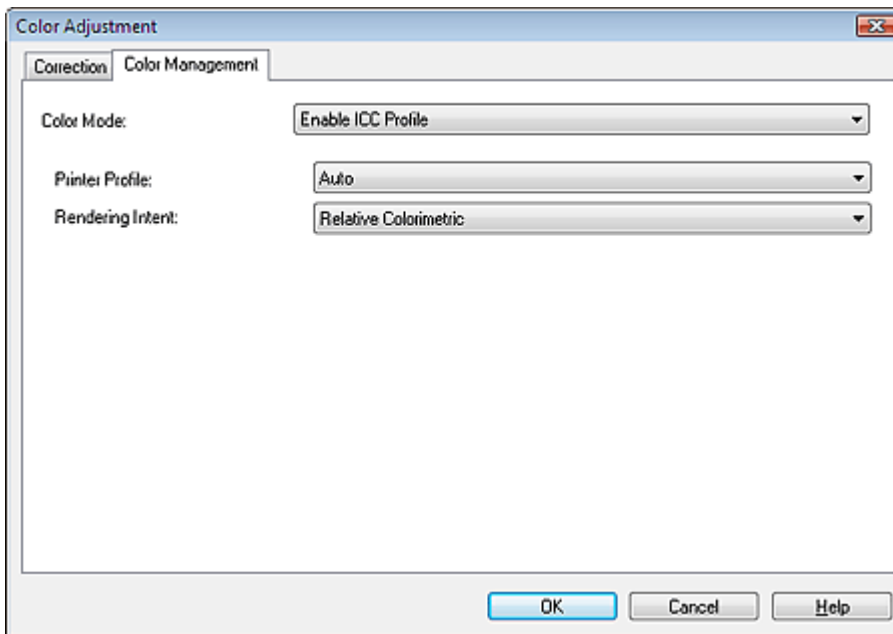

4. Select Photo Color for Color Mode.

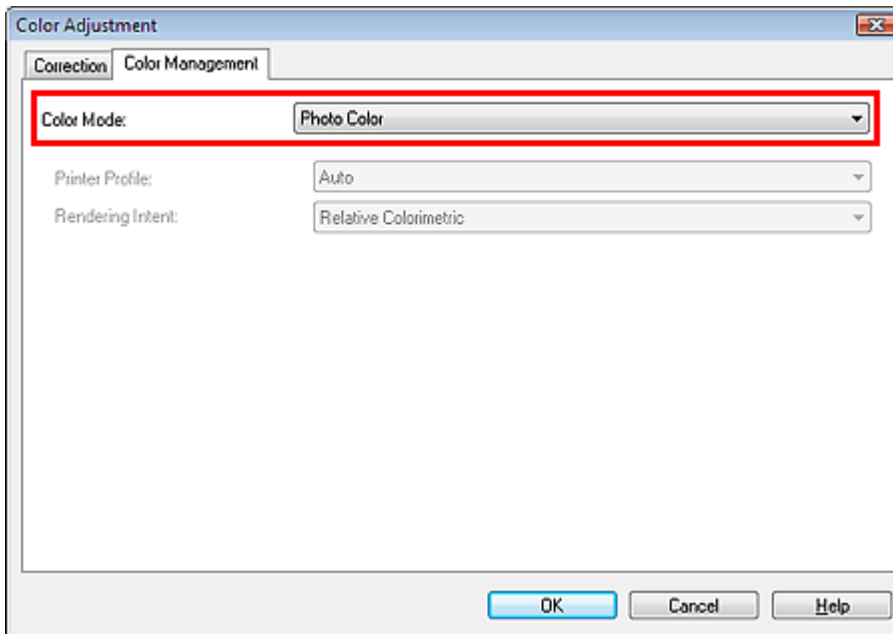

5. Click OK.

6. Click Print.

The Print dialog box appears.

7. Click OK.

Note

- You can also change the color balance, brightness and contrast of the image.
 - ➔ Adjusting the Color Balance
 - ➔ Adjusting Brightness/Contrast

Advanced Guide

Advanced Guide > Printing from a Computer > Printing with the Bundled Application Software > Printing Beautiful Photos > Printing According to the Lighting in the Viewing Environment

Easy-PhotoPrint Pro

Printing According to the Lighting in the Viewing Environment

You can print in color tones suitable for the lighting conditions of the places where images are viewed, displayed or exhibited by using a function that reduces the differences in the way images appear in different lighting conditions.

Important

- You may not be able to print with this setting depending on the printer and media type.

Note

- This function is supported under Windows Vista only.

1. Start Easy-PhotoPrint Pro and select the photo you want to print.

The photo appears in the bottom right area of the screen.

Note

- See "[Selecting a Photo](#)" for details on how to select photos.

2. In the Printer Settings window, click Color Adjustment....

The Color Adjustment dialog box appears.

3. Click the Color Management tab.

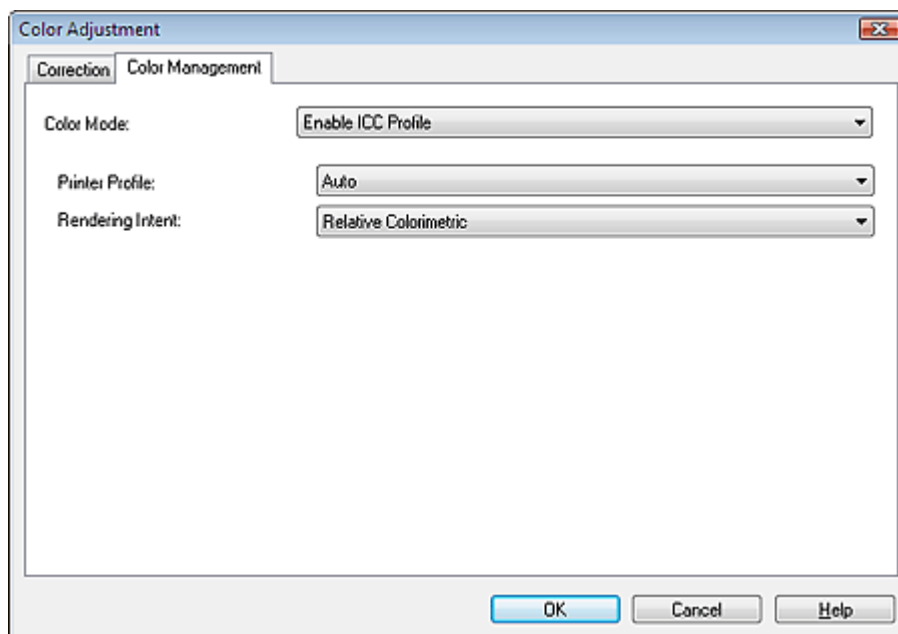

4. Select Ambient Light Correction for Color Mode.

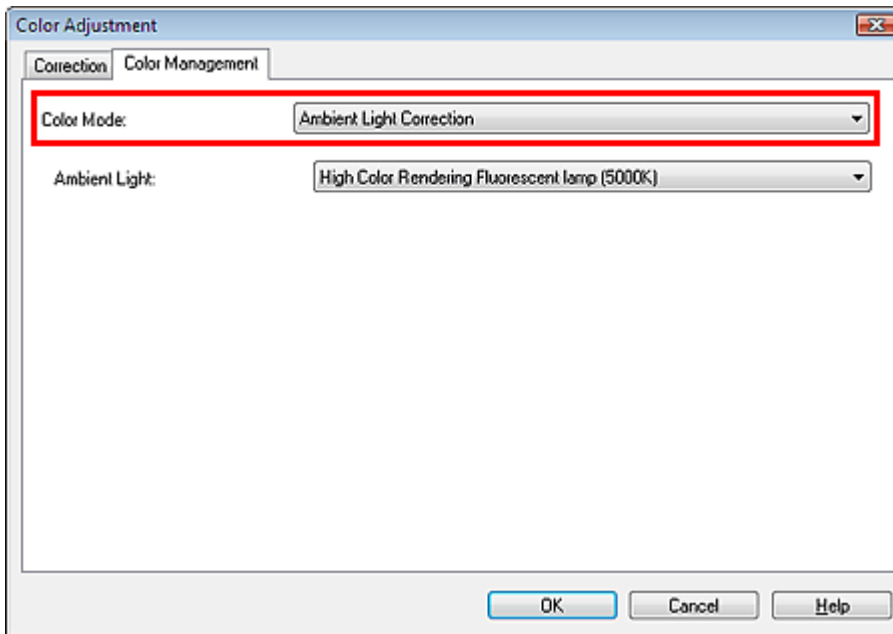

5. Select the lighting (ambient light) in the place where you use the prints from Ambient Light.

Note

- From Ambient Light, you can select the following lighting options.
 - High Color Rendering Fluorescent lamp (6500K)
 - High Color Rendering Fluorescent lamp (5000K)
 - High Color Rendering Fluorescent lamp (3000K)
 - Triphosphor Fluorescent lamp (6500K)
 - Triphosphor Fluorescent lamp (5000K)
 - Triphosphor Fluorescent lamp (4000K)
 - Triphosphor Fluorescent lamp (3000K)
 - Normal Fluorescent lamp (4000K)
- *The name may vary depending on your fluorescent lamp.
- High color rendering fluorescent lamp: Lamp with high color rendering properties (good color appearance), used for color evaluation, comparison, inspection, etc., where accurate color management is required. 5000K is often used for evaluation of printed materials.
- Triphosphor fluorescent lamp: Lamp widely used for general household lighting.
- Normal fluorescent lamp: Lamp with low color rendering properties (poor color appearance) compared to high color rendering lamps or triphosphor lamps.
- Select a higher K value for a cooler tint, and select a lower K value for a warmer tint.

6. Click OK.

7. Click Print.

The Print dialog box appears.

8. Click OK.

Note

- You can also change the color balance, brightness and contrast of the image.
 - ➔ [Adjusting the Color Balance](#)
 - ➔ [Adjusting Brightness/Contrast](#)

Advanced Guide

Advanced Guide > Printing from a Computer > Printing with the Bundled Application Software > Printing with Easy-PhotoPrint Pro

Easy-PhotoPrint Pro

Printing with Easy-PhotoPrint Pro

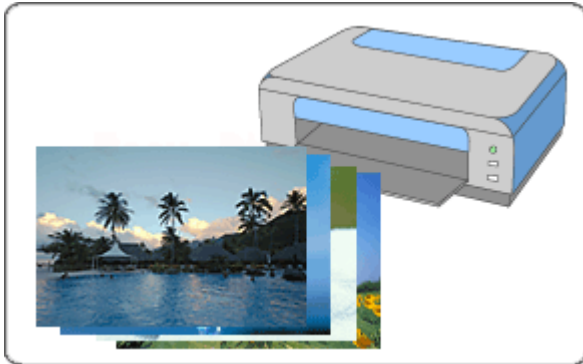

Steps

1. Starting Easy-PhotoPrint Pro
2. Selecting a Photo
3. Selecting the Paper and Layout
4. Printing

Adjust the Colors of Photo

- ➔ Printing Photos in Grayscale
- ➔ Adjusting the Color Balance
- ➔ Adjusting Color Balance Using Sample Patterns
- ➔ Adjusting Brightness/Contrast
- ➔ Adjusting Brightness/Contrast Using Sample Patterns

Try This

- ➔ Printing Borderless Photos
- ➔ Printing an Index
- ➔ Printing Contact Sheets
- ➔ Printing Advanced Information
- ➔ Trimming Photos
- ➔ Printing with Adjusted Print Size
- ➔ Saving Print Settings

[Page top](#)↑

Advanced Guide

Advanced Guide > Printing from a Computer > Printing with the Bundled Application Software > Printing with Easy-PhotoPrint Pro > Starting Easy-PhotoPrint Pro

Easy-PhotoPrint Pro

Starting Easy-PhotoPrint Pro

Easy-PhotoPrint Pro can be started from Adobe Photoshop or Digital Photo Professional.

Starting from Adobe Photoshop

1. From the File menu of Adobe Photoshop, select Automate > Canon Easy-PhotoPrint Pro....

Easy-PhotoPrint Pro starts.



Important

- Easy-PhotoPrint Pro cannot be started when no image is displayed in Adobe Photoshop.
- If Easy-PhotoPrint Pro does not appear in Adobe Photoshop's menu even after installing Easy-PhotoPrint Pro, follow these steps to install the Photoshop Plug-In.
 1. Exit Adobe Photoshop.
 2. From the Start menu, select (All) Programs > Canon Utilities > Easy-PhotoPrint Pro > Photoshop Plug-In Installer.
 3. Follow the on-screen instructions to install.

*The Photoshop Plug-In will not be installed if Adobe Photoshop has never been started.
- If you create or edit an image in Adobe Photoshop CS3 using the layer function, the image may not be displayed in Easy-PhotoPrint Pro.
In this case, combine the image and the layer in Adobe Photoshop CS3.

Note

- The images displayed in Adobe Photoshop appear in Easy-PhotoPrint Pro.

Starting from Digital Photo Professional

1. From the File menu of Digital Photo Professional, select Plug-in printing > Print with Easy-PhotoPrint Pro.

Easy-PhotoPrint Pro starts.

 **Important**

- Easy-PhotoPrint Pro cannot be started when no image is displayed in Digital Photo Professional.

 **Note**

- The images displayed in Digital Photo Professional appear in Easy-PhotoPrint Pro.

[Page top](#)

Advanced Guide

Advanced Guide > Printing from a Computer > Printing with the Bundled Application Software > Printing with Easy-PhotoPrint Pro > Selecting a Photo





Easy-PhotoPrint Pro

Selecting a Photo

1. Check that the photo you want to print is displayed in the bottom right area of the screen.



Note

- To increase the number of copies, click  (Up arrow) below the thumbnail in the center of the screen until the number of copies you want is reached. To reduce the number of copies shown in the box, click  (Down arrow).
- You can select up to 99 copies per one image and 1,000 copies in total.
- You can change the printing order by clicking  (Specify Print Order) in the Print Preview window.
- You can resize the thumbnails by clicking  (Specify Thumbnail Size) in the thumbnail window.
- Click  (Clear Image Selection) to cancel all selections.



Page top↑

Advanced Guide

Advanced Guide > Printing from a Computer > Printing with the Bundled Application Software > Printing with Easy-PhotoPrint Pro > Selecting the Paper and Layout

Easy-PhotoPrint Pro

Selecting the Paper and Layout

1. Set the following items according to the printer and paper to be used:

Printer

Paper Size

Media Type

Paper Source



Important

- When Fine Art is selected for Paper Size, a 1.38 inch (35 mm) margin is automatically left at the top and bottom of the paper. It is recommended that you check the print range with the image shown in Preview before printing.

Note

- The paper sizes and media types may vary depending on the printer.
- The paper sources may vary depending on the printer and the media type.
- Select the XPS printer driver ("Your model name XPS") for Printer to print in the High Dynamic Range (full 16-bit workflow). See "[XPS Printer Driver](#)" for details on the XPS printer driver.

2. Select a print quality from Print Quality.

Note

- The available print quality options may vary depending on the printer and media type.

3. Select a layout from Layout.

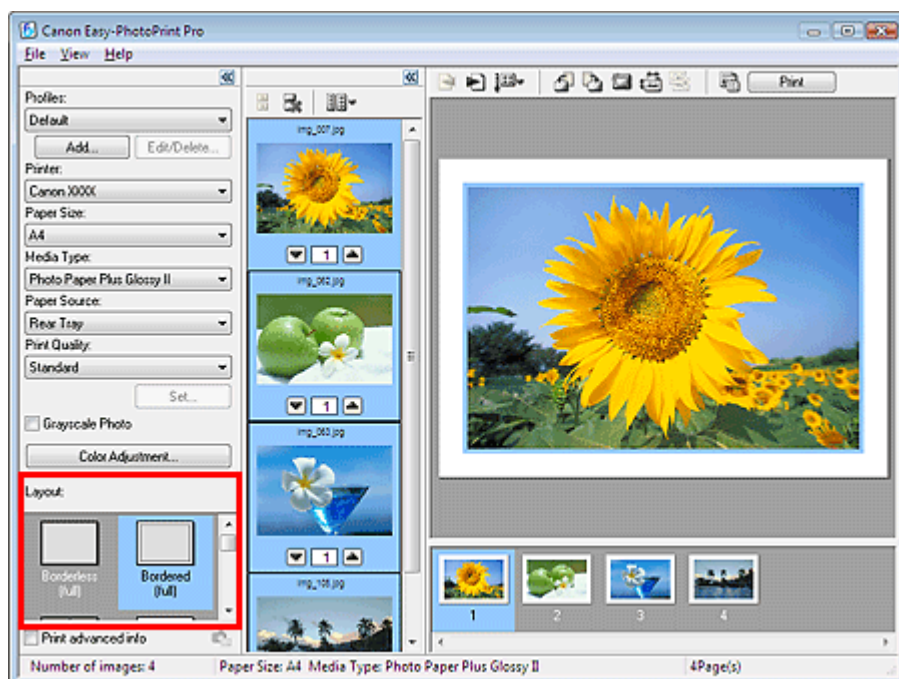

Important

- When Plain Paper is selected for Media Type and Bordered (full) is selected for Layout, the print result may be soft. In that case, change Media Type or Layout and print again.

Note

- The layouts may vary depending on the printer, paper size, and media type.

Note

- For borderless photos and index prints, you can make advanced settings such as the amount of extension and the arrangement of images. After selecting a layout, click Set... that appears to the right of Layout.
- When you select Bordered (full) for Layout, you can specify the print size and amount of margin.
 - ➔ [Printing with Adjusted Print Size](#)
- You can also change the color balance, brightness and contrast of the image.
 - ➔ [Adjusting the Color Balance](#)
 - ➔ [Adjusting Brightness/Contrast](#)



Advanced Guide

Advanced Guide > Printing from a Computer > Printing with the Bundled Application Software > Printing with Easy-PhotoPrint Pro > Printing

Easy-PhotoPrint Pro

Printing

1. Click Print.

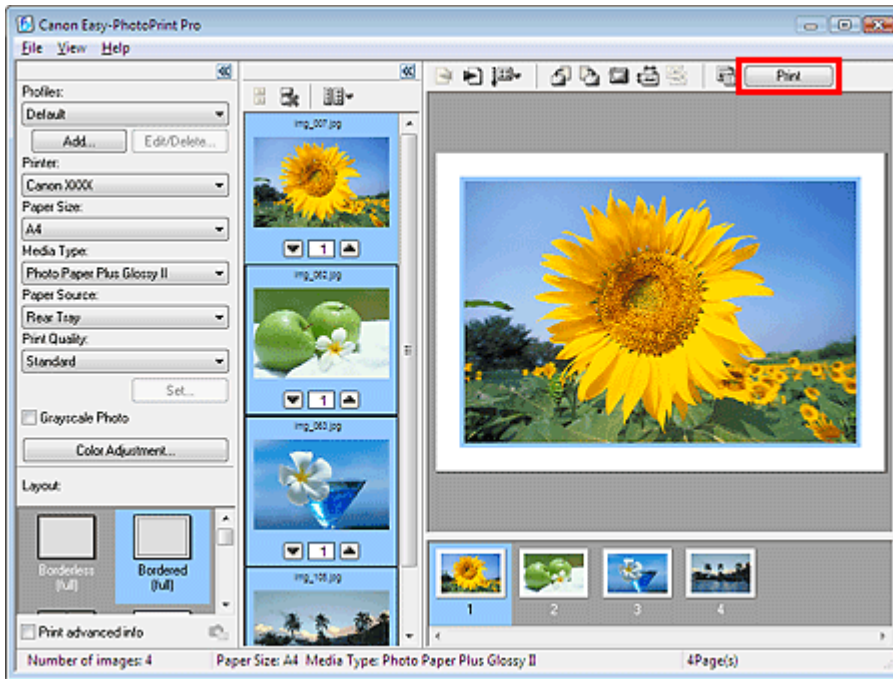

The Print dialog box appears.

Note

- You can change the printing order by clicking  (Specify Print Order) in the Print Preview window.

2. Click OK.

Important

- If "An error occurred during printing. Memory may be insufficient for printing." appears while printing with Easy-PhotoPrint Pro started from Adobe Photoshop, increasing the memory allocation for Adobe Photoshop may solve the problem.

Note

- Select the XPS printer driver for Printer to print in the High Dynamic Range (full 16-bit workflow). See "XPS Printer Driver" for details on the XPS printer driver.
- You can print photos in grayscale or crop photos. You can also print in various styles including index prints and contact sheets.
 - ➔ Printing Photos in Grayscale
 - ➔ Trimming Photos
 - ➔ Printing Borderless Photos
 - ➔ Printing an Index
 - ➔ Printing Contact Sheets
 - ➔ Printing Advanced Information



Advanced Guide

Advanced Guide > Printing from a Computer > Printing with the Bundled Application Software > Adjust the Colors of Photo

Easy-PhotoPrint Pro

Adjust the Colors of Photo

- ➔ Printing Photos in Grayscale
- ➔ Adjusting the Color Balance
- ➔ Adjusting Color Balance Using Sample Patterns
- ➔ Adjusting Brightness/Contrast
- ➔ Adjusting Brightness/Contrast Using Sample Patterns

Page top↑

Advanced Guide

Advanced Guide > Printing from a Computer > Printing with the Bundled Application Software > Adjust the Colors of Photo > Printing Photos in Grayscale

Easy-PhotoPrint Pro

Printing Photos in Grayscale

You can print color photos in grayscale photos.



1. Check that the photo you want to print is displayed in the bottom right area of the screen.

Note

- See "Selecting a Photo" for details on how to select photos.

2. Select the Grayscale Photo checkbox in the Printer Settings window.

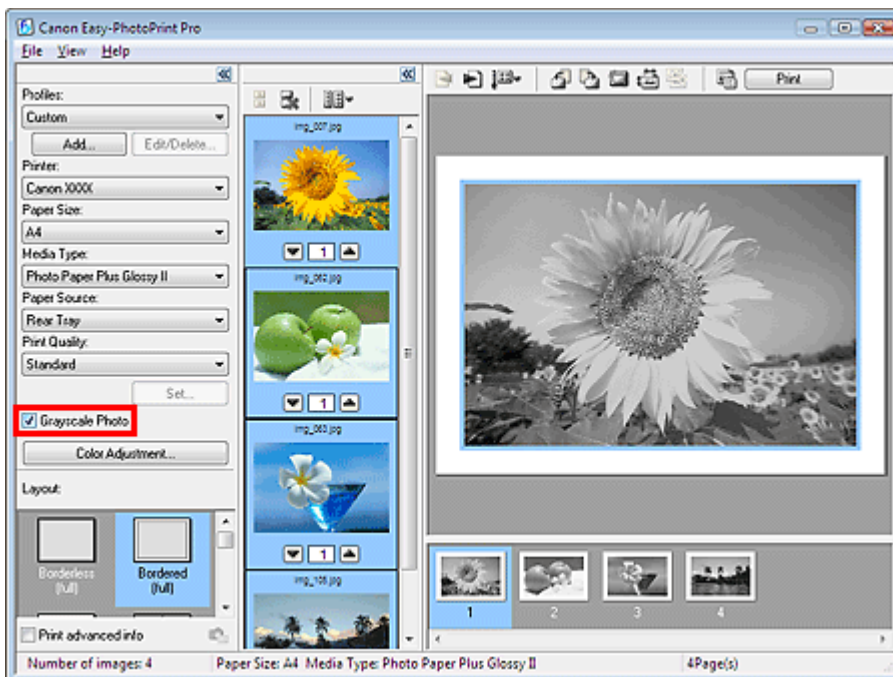

Important

- When you select the Grayscale Photo checkbox, all the selected images will be printed in grayscale.

Note

- You can adjust the black color tone in the Color Adjustment dialog box. To display the Color Adjustment dialog box, select the Grayscale Photo checkbox in the Printer Settings window and click Color Adjustment.... See Help for details.

3. Click Print.

The Print dialog box appears.

4. Click OK.

Important

- White streaks may appear at the top and bottom edges of grayscale photos. In that case, print with a 45 mm (1.77 inch) or more margin at the top and bottom edges.
If you select Bordered (Margin 45) for Layout, images will be reduced when printing to allow a 45 mm (1.77 inch) margin at the top and bottom edges relative to the printing direction.

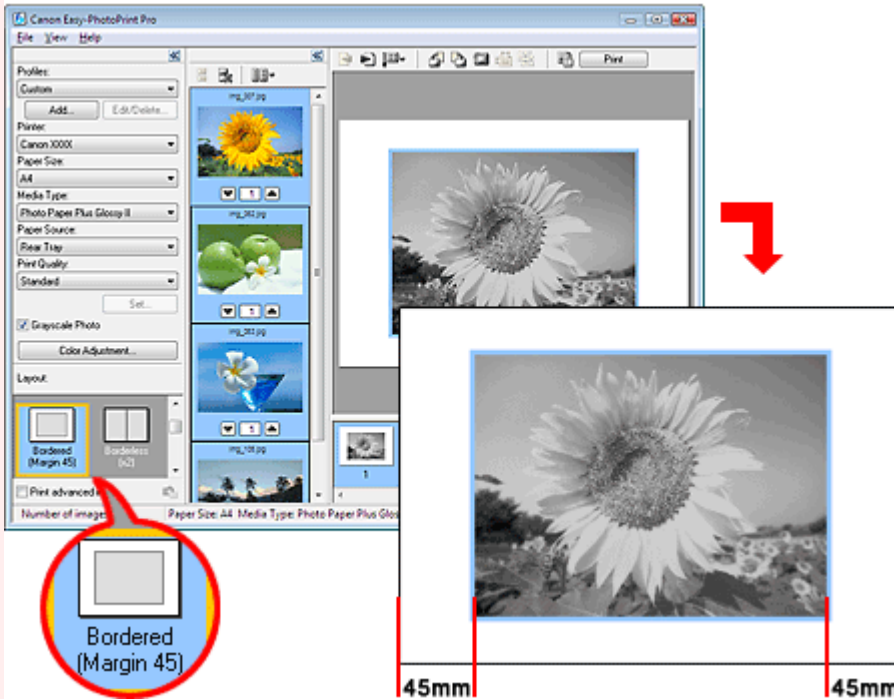

- If the print result after adjusting the color balance in the Color Adjustment dialog box is different from the preview image, print a color pattern and adjust the colors based on the pattern.

➔ [Adjusting Color Balance Using Sample Patterns](#)

Advanced Guide

Advanced Guide > Printing from a Computer > Printing with the Bundled Application Software > Adjust the Colors of Photo > Adjusting the Color Balance

Easy-PhotoPrint Pro

Adjusting the Color Balance

You can adjust the color balance of an image.

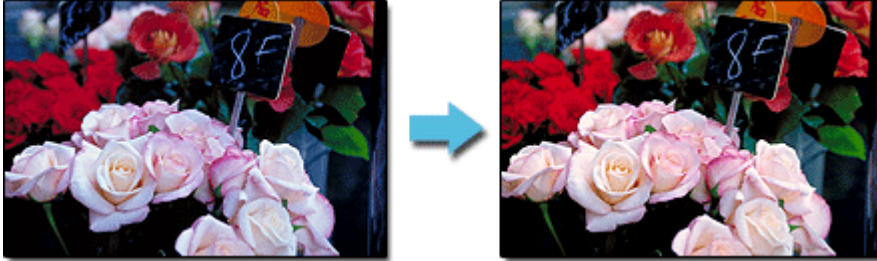

1. Check that the photo you want to print is displayed in the bottom right area of the screen.

Note

- See "Selecting a Photo" for details on how to select photos.

2. Click Color Adjustment... in the Printer Settings window.

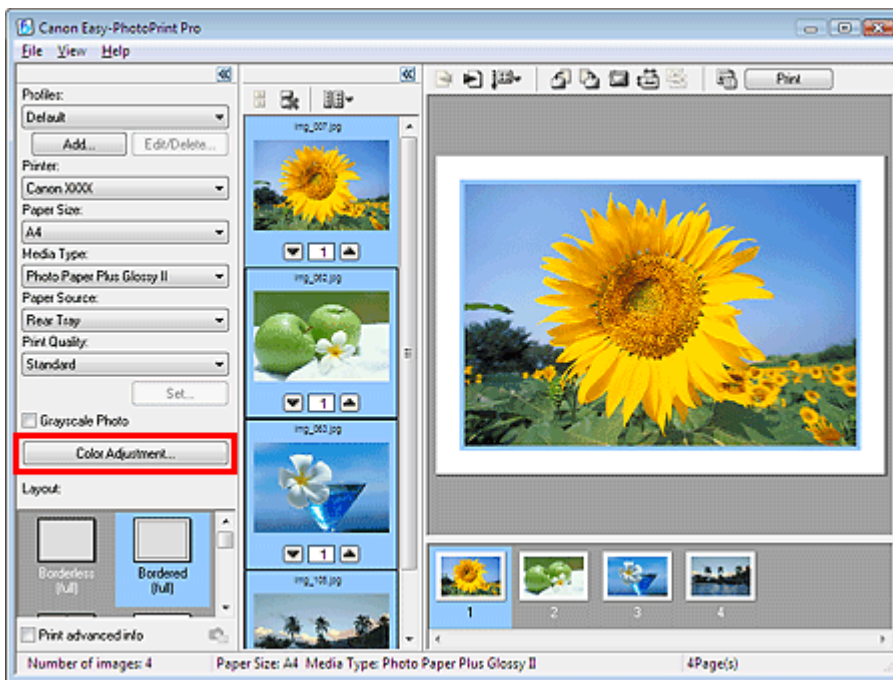

The Color Adjustment dialog box appears.

3. Adjust the intensity for Cyan, Magenta and Yellow in Color Balance.

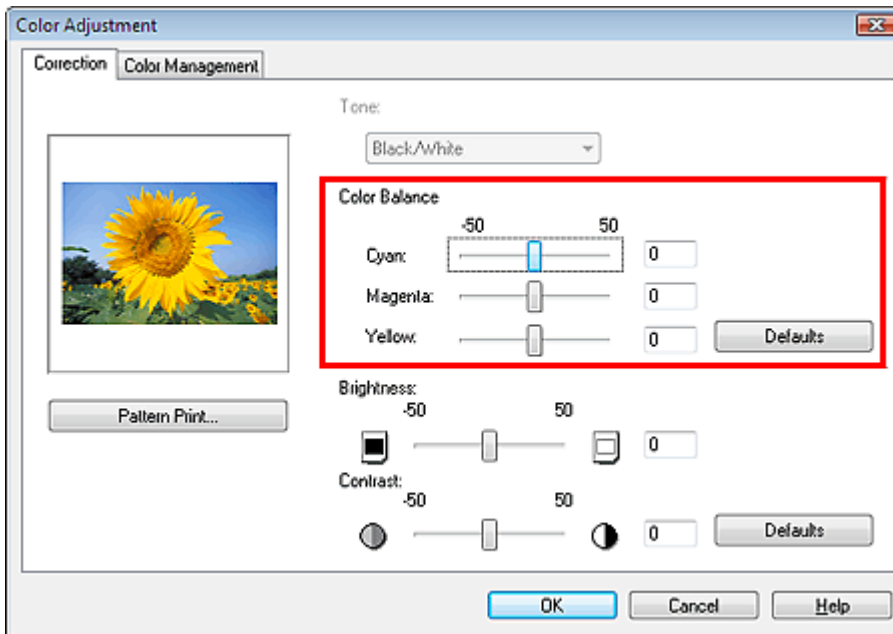

Important

- If the print result after adjusting the color balance is different from the preview image, print a color pattern and adjust the colors based on the pattern.
 - ➔ [Adjusting Color Balance Using Sample Patterns](#)
- The color balance adjustment applies to all images to print.

Note

- Move the slider to the right to increase and left to reduce intensity.

4. Click OK.

Advanced Guide

Advanced Guide > Printing from a Computer > Printing with the Bundled Application Software > Adjust the Colors of Photo > Adjusting Color Balance Using Sample Patterns

Easy-PhotoPrint Pro

Adjusting Color Balance Using Sample Patterns

You can print a pattern of an image and adjust the color balance of the image based on the pattern.

1. Check that the photo you want to print is displayed in the bottom right area of the screen.

Note

- See "[Selecting a Photo](#)" for details on how to select photos.

2. Click Color Adjustment... in the Printer Settings window.

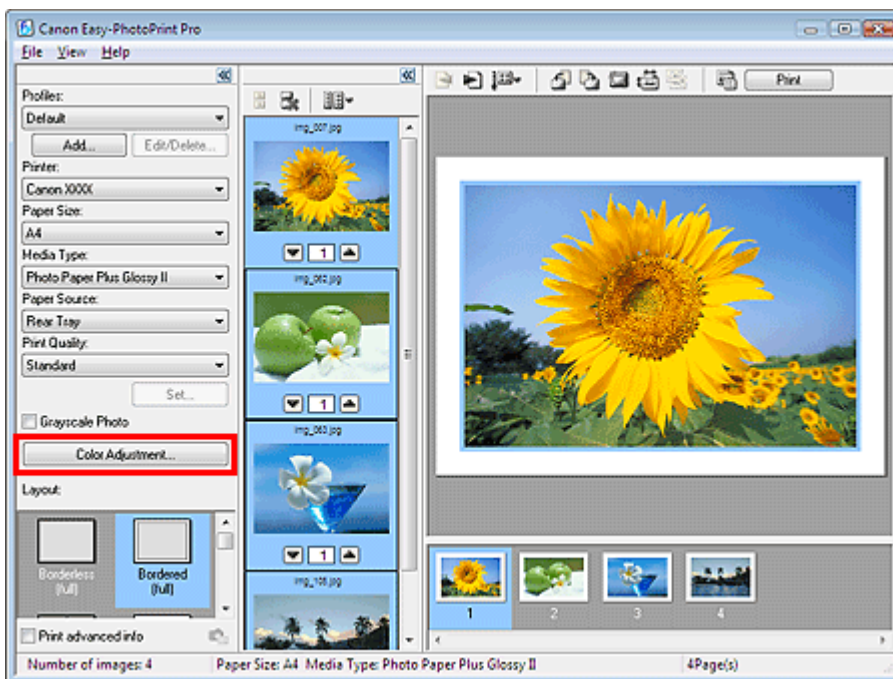

The Color Adjustment dialog box appears.

3. Click Pattern Print....

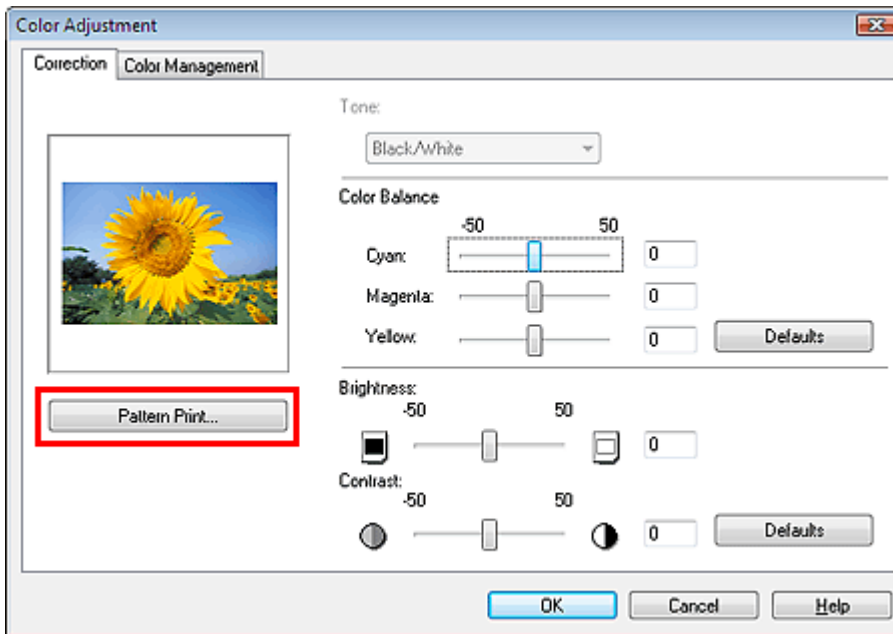

The Pattern Print window appears.

4. Select Color for Pattern Print, then select the color direction in which you want to adjust.

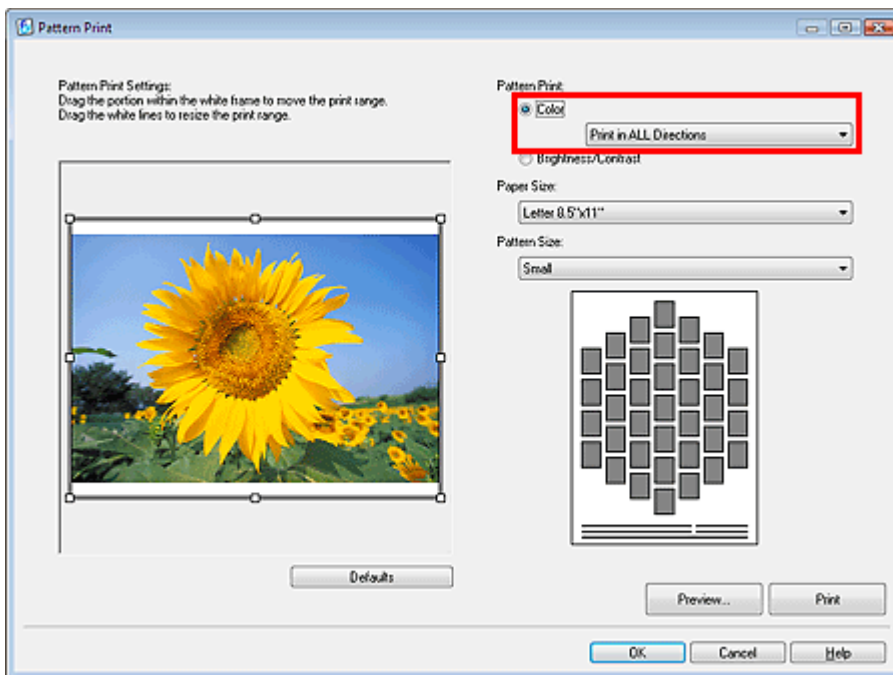

Note

- Select Print in ALL Directions to print a pattern of the image adjusted in the following six directions. (The image with the current color balance values is printed in the center.) Use the pattern to determine the color direction in which you want to adjust the color balance.

R (upper right) direction : Red

Y (upper) direction : Yellow

G (upper left) direction : Green

C (lower left) direction : Cyan

B (lower) direction : Blue

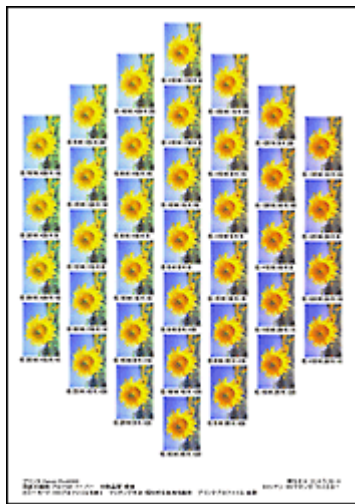

M (lower right) direction : Magenta

- Select a specific direction such as Print in Direction R to print a pattern of the image adjusted in the selected direction. (The image with the current color balance values is printed at the bottom left.) For example, select Print in Direction R to print a more detailed pattern of the portion in the R direction of the pattern for all directions (the portion outlined in red in the figure below). This allows you to check more variations than in all directions.

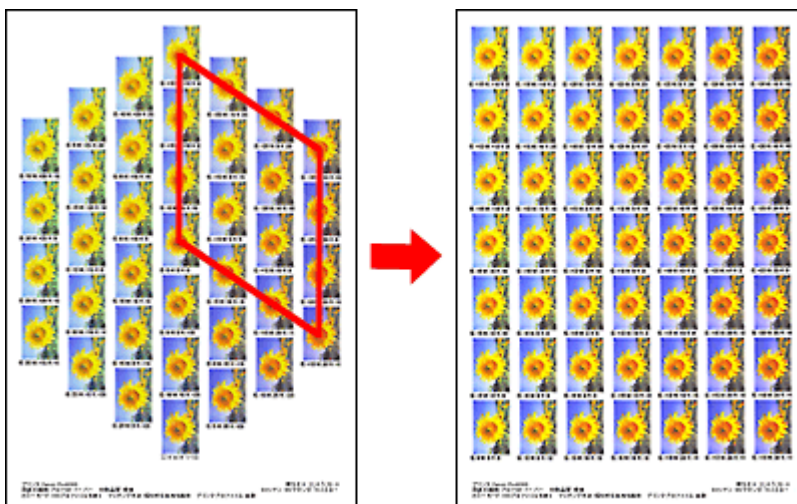

5. Select Paper Size and Pattern Size.

Note

- You can crop the image before printing the pattern. Move the white frame in Preview to change the cropping area.
- Click Preview... to display the print preview in a different window in which you can check the settings before printing.
- See Help for details on the Pattern Print window.

6. Click Print.

The pattern is printed.

7. Click OK.

8. Select the image with the desired color balance from the printed pattern and enter the values indicated below the image into Color Balance.

9. Click OK.

Advanced Guide

Advanced Guide > Printing from a Computer > Printing with the Bundled Application Software > Adjust the Colors of Photo > Adjusting Brightness/Contrast

Easy-PhotoPrint Pro

Adjusting Brightness/Contrast

You can adjust the brightness and contrast of an image.

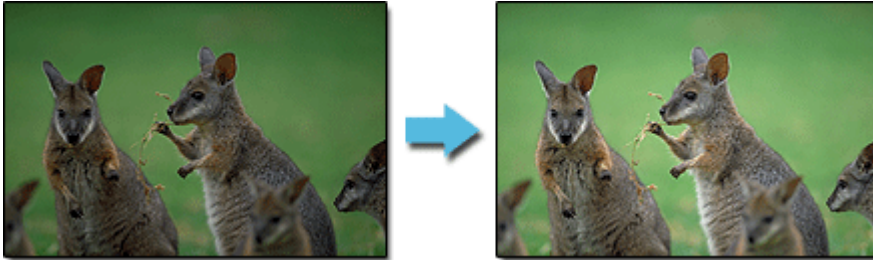

1. Check that the photo you want to print is displayed in the bottom right area of the screen.

Note

- See "Selecting a Photo" for details on how to select photos.

2. Click Color Adjustment... in the Printer Settings window.

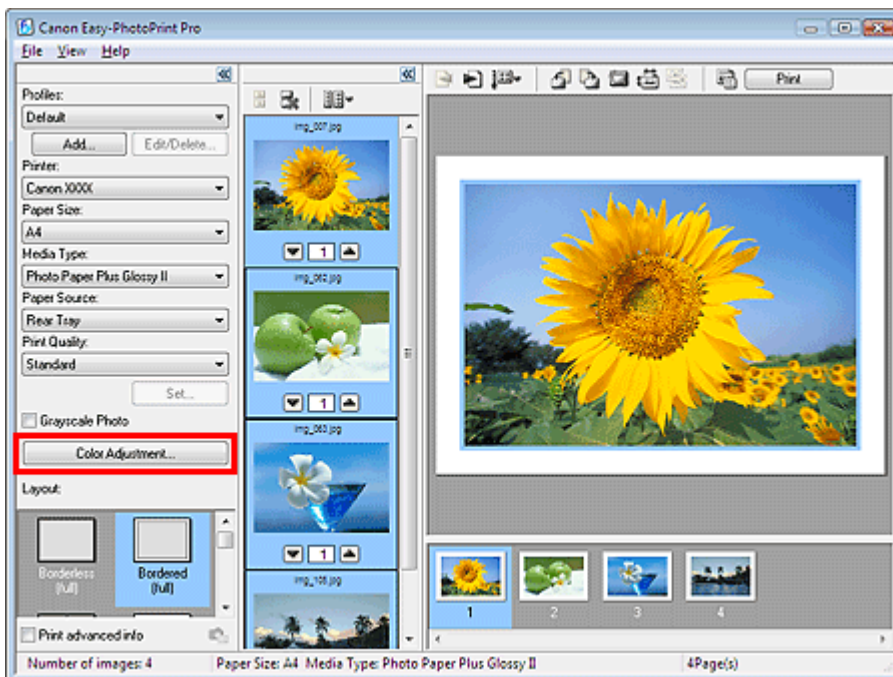

The Color Adjustment dialog box appears.

3. Adjust Brightness and Contrast.

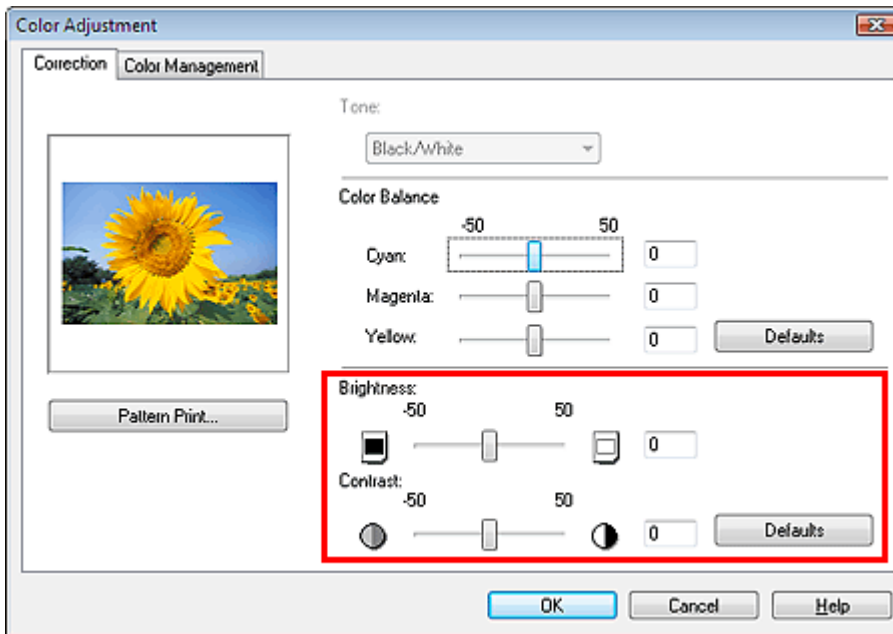

Important

- If the print result after adjusting the brightness and contrast is different from the preview image, print a color pattern and adjust the colors based on the pattern.
 - ➔ [Adjusting Brightness/Contrast Using Sample Patterns](#)
- The brightness/contrast adjustment applies to all images to print.

Note

- For Brightness, move the slider to the right to brighten and left to darken the image.
- For Contrast, move the slider to the right to increase and left to reduce the contrast of the image.

4. Click OK.

Advanced Guide

Advanced Guide > Printing from a Computer > Printing with the Bundled Application Software > Adjust the Colors of Photo > Adjusting Brightness/Contrast Using Sample Patterns

Easy-PhotoPrint Pro

Adjusting Brightness/Contrast Using Sample Patterns

You can print a pattern of an image and adjust the brightness/contrast of the image based on the pattern.

1. Check that the photo you want to print is displayed in the bottom right area of the screen.

Note

- See "Selecting a Photo" for details on how to select photos.

2. Click Color Adjustment... in the Printer Settings window.

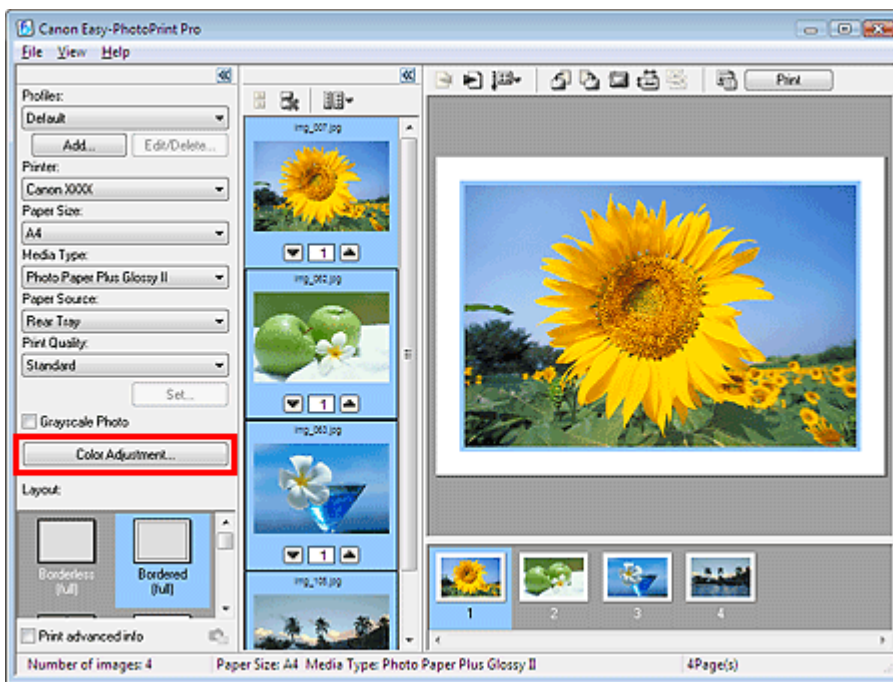

The Color Adjustment dialog box appears.

3. Click Pattern Print....

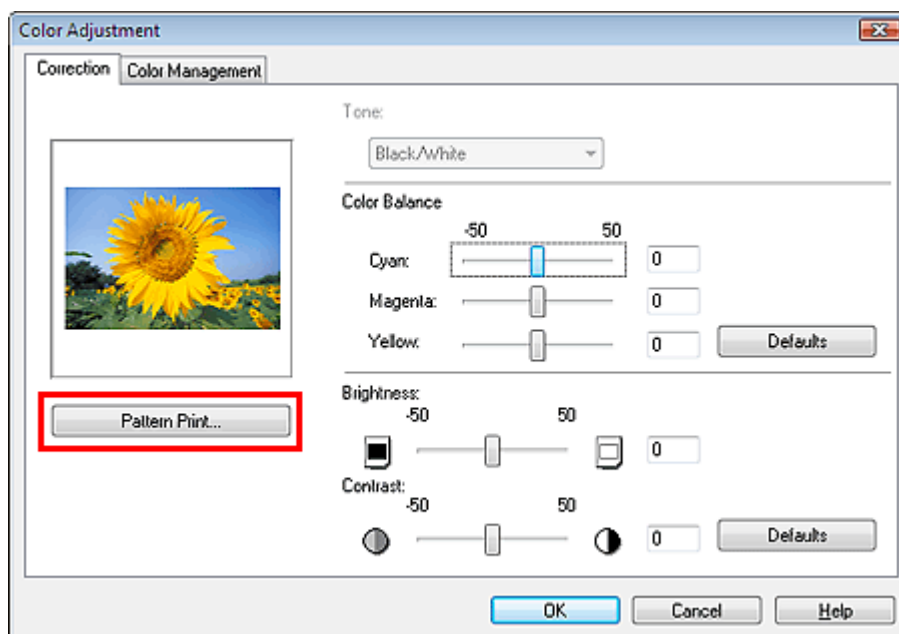

The Pattern Print window appears.

4. Select Brightness/Contrast for Pattern Print.

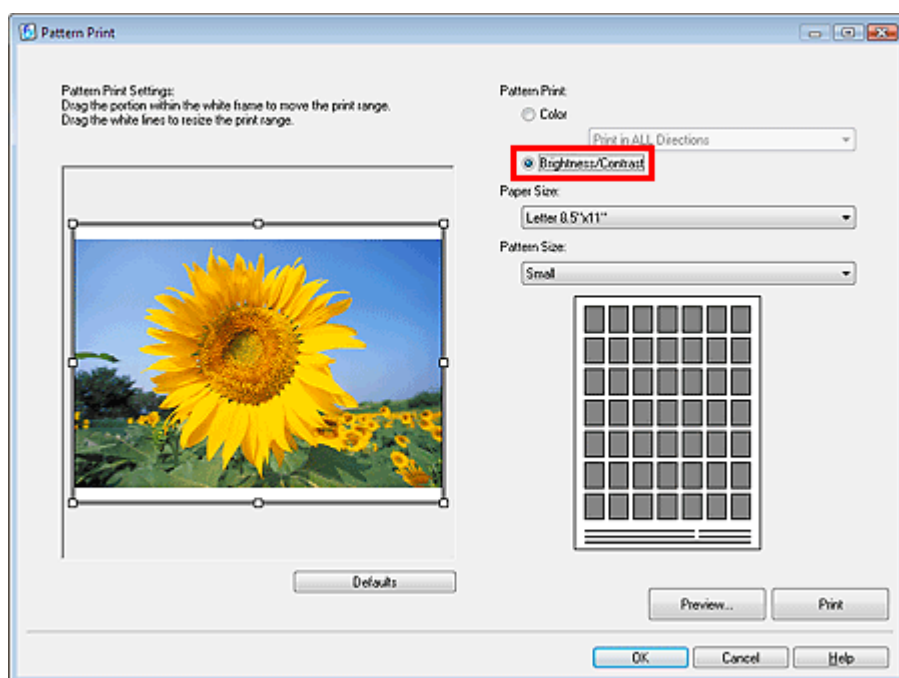

5. Select Paper Size and Pattern Size.

Note

- You can crop the image before printing the pattern. Move the white frame in Preview to change the cropping area.
- Click Preview... to display the print preview in a different window in which you can check the settings before printing.
- See Help for details on the Pattern Print window.

6. Click Print.

The pattern is printed.

Note

- The source image is printed in the center. Brightness increases from bottom to top. Contrast increases from left to right.

7. Click OK.
8. Select the image with the desired brightness/contrast from the printed pattern and enter the values indicated below the image into Brightness and Contrast.
9. Click OK.

[Page top](#)↑

Advanced Guide

Advanced Guide > Printing from a Computer > Printing with the Bundled Application Software > Easy-PhotoPrint Pro Settings

Easy-PhotoPrint Pro

Easy-PhotoPrint Pro Settings

- ➔ [Printing Borderless Photos](#)
- ➔ [Printing an Index](#)
- ➔ [Printing Contact Sheets](#)
- ➔ [Printing Advanced Information](#)
- ➔ [Trimming Photos](#)
- ➔ [Printing with Adjusted Print Size](#)
- ➔ [Saving Print Settings](#)

[Page top](#)↑

Advanced Guide

Advanced Guide > Printing from a Computer > Printing with the Bundled Application Software > Easy-PhotoPrint Pro Settings > Printing Borderless Photos

Easy-PhotoPrint Pro

Printing Borderless Photos

You can print borderless photos by selecting a borderless layout from Layout in the Printer Settings window.



Note

- Select a borderless layout and click Set... that appears to the right of Layout to display the Set Amount of Extension of Borderless Printing dialog box in which you can specify the amount of extension. See Help for details.

[Page top](#)

Advanced Guide

Advanced Guide > Printing from a Computer > Printing with the Bundled Application Software > Easy-PhotoPrint Pro Settings > Printing an Index

Easy-PhotoPrint Pro

Printing an Index

You can print an index of selected photos. An index print shows the thumbnails of the photos in one page. It is convenient for managing your photos.

To print an index, select Index for Layout in the Printer Settings window.

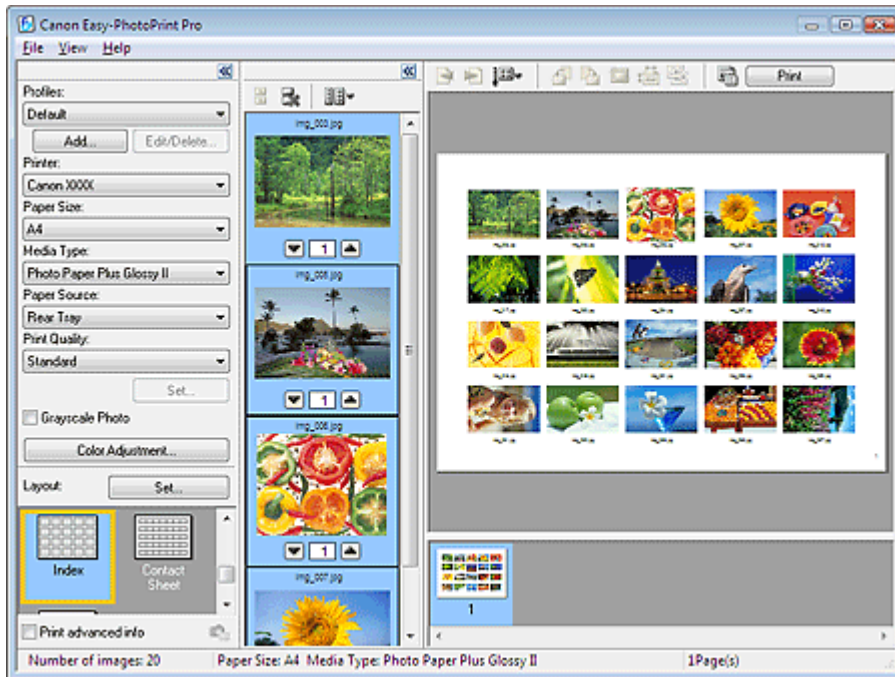

Important

- You can print up to 80 images on one page.

Note

- Index prints can only be printed on Letter 8.5"x11", A4 and A3 paper.
- Select Index and click Set... that appears to the right of Layout to change the number of columns and rows, or add a header/footer.

[Page top](#)

Advanced Guide

Advanced Guide > Printing from a Computer > Printing with the Bundled Application Software > Easy-PhotoPrint Pro Settings > Printing Contact Sheets

Easy-PhotoPrint Pro

Printing Contact Sheets

You can print an index of photos with a design that looks like negative film strips.

To print a contact sheet, select Contact Sheet for Layout in the Printer Settings window.

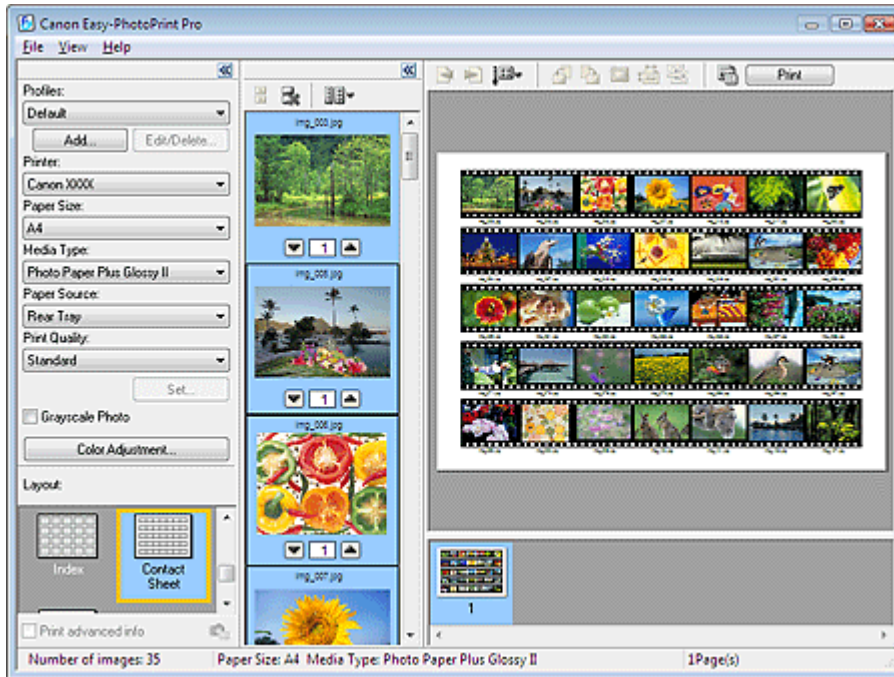

Note

- Contact sheets can only be printed on Letter 8.5"x11" and A4 paper.

[Page top](#)↑

Advanced Guide

Advanced Guide > Printing from a Computer > Printing with the Bundled Application Software > Easy-PhotoPrint Pro Settings > Printing Advanced Information

Easy-PhotoPrint Pro

Printing Advanced Information

Select the Print advanced info checkbox in the Printer Settings window to print the photo with photo information or color correction information side by side.

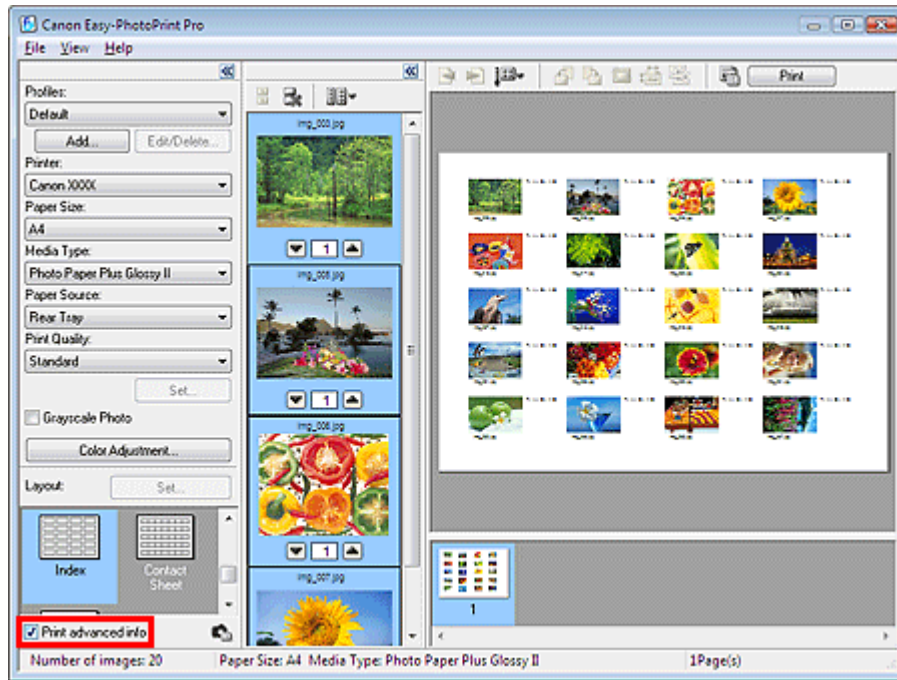

Note

- Displayed photo information items may vary depending on the application from which Easy-PhotoPrint Pro is started.
- Click  (Advanced Information Settings) to customize the information display (print position, item, etc.). See Help for details.
- The following combinations of layout and paper size are available for printing photo information or color correction information.

Layout	Paper Size
Bordered (full)	A4, Letter 8.5"x11", A3, A3+ 13"x19" 329x483mm, 11"x17" 279.4x431.8mm, Art A4 (Margin 35), Art Letter (Margin 35), Art A3 (Margin 35), Art A3+ 13x19 (Margin 35), 4"x6" 10x15cm, 5"x7" 13x18cm, 4"x8" 101.6x203.2mm, 8"x10" 20x25cm, 10"x12" 25x30cm, 14"x17" 36x43cm
Bordered (x2) Bordered (x4)	A4, Letter 8.5"x11", A3, A3+ 13"x19" 329x483mm, 11"x17" 279.4x431.8mm, Art A4 (Margin 35), Art Letter (Margin 35), Art A3 (Margin 35), Art A3+ 13x19 (Margin 35), 8"x10" 20x25cm, 10"x12" 25x30cm, 14"x17" 36x43cm
Index (*)	A4, Letter 8.5"x11"

*When Index is selected for Layout, only photo information is printed.

*When Index is selected for Layout, image arrangement is automatically changed to four columns and five rows.

- To change the print position of photo information for each image, select an image and click  (Change the photo information position for the image.).

Advanced Guide

Advanced Guide > Printing from a Computer > Printing with the Bundled Application Software > Easy-PhotoPrint Pro Settings > Trimming Photos

Easy-PhotoPrint Pro

Trimming Photos

Cropping a photo is the act of removing the unnecessary portions of the photo by selecting the necessary portions.

Click  (Trimming) in the Print Preview window or double-click the preview image. Move the white frame to the portion to crop and click OK.

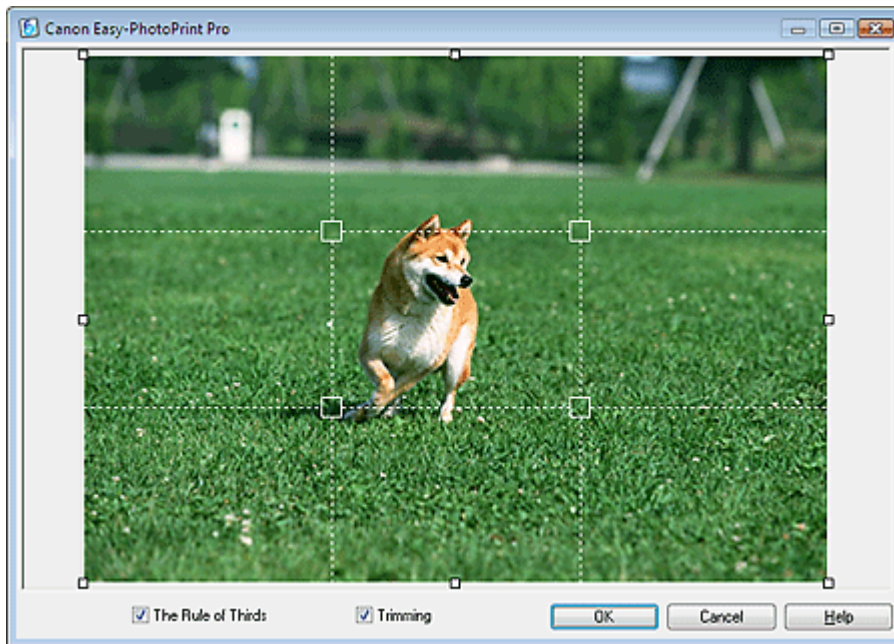

Note

- To move the cropping area, place the cursor within the white frame and drag it. Drag the white lines to enlarge/reduce the cropping area.
- Select the The Rule of Thirds checkbox to display white broken lines. To create a balanced composition, drag any of the intersecting points (white squares) or white broken lines over the main subject of the photo.

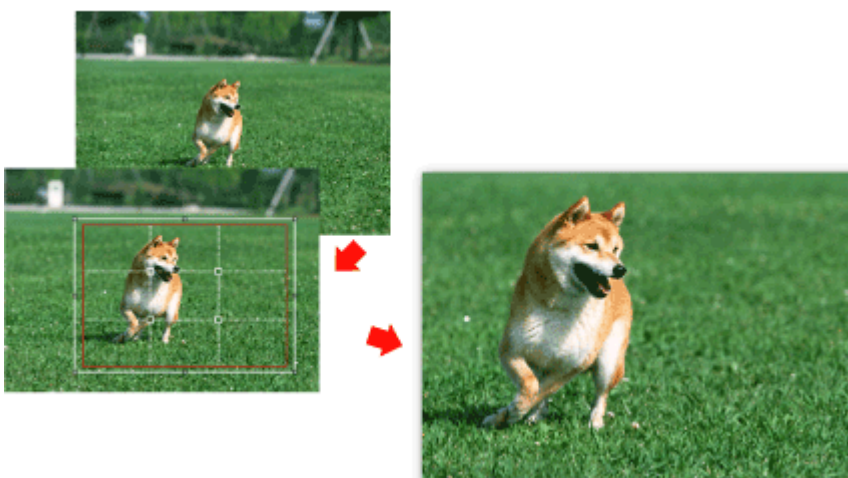

- The cropping effect applies only to the print result. The original image will not be cropped.

Advanced Guide

Advanced Guide > Printing from a Computer > Printing with the Bundled Application Software > Easy-PhotoPrint Pro Settings > Printing with Adjusted Print Size

Easy-PhotoPrint Pro

Printing with Adjusted Print Size

Click  (Specify Print Size) in the Print Preview window to adjust the print size and amount of margin before printing.

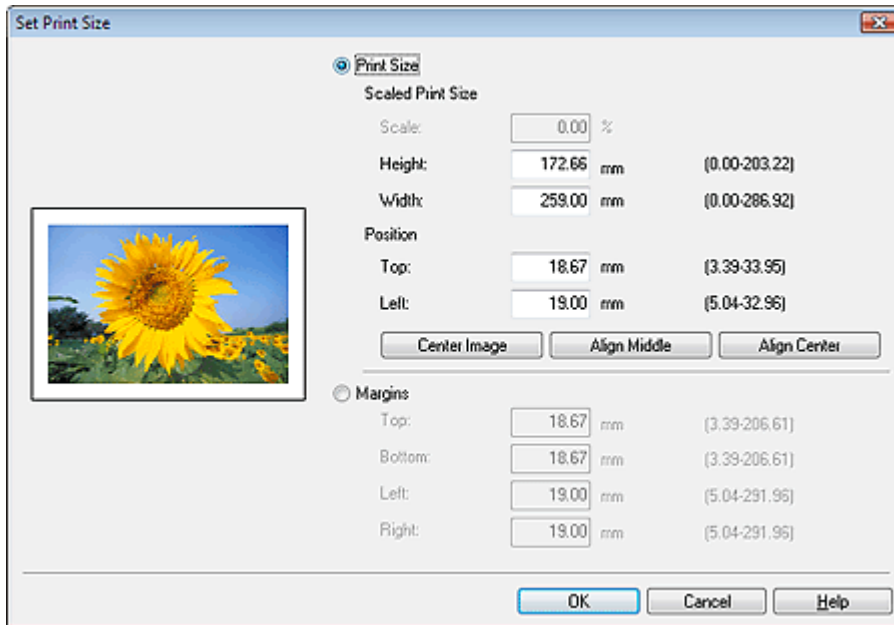

Important

- Set Printer, Paper Size and Layout before changing the values in Scale, Height, etc. in the Set Print Size dialog box. If you change Printer, Paper Size or Layout after changing the values, the original values return.
- To return the Scale, Height and other values in the Set Print Size dialog box to the original values, set the number of copies below the thumbnail to 0, then specify the number again.

Note

- Print size can be adjusted only when Bordered (full) is selected for Layout.
- Margins can be adjusted only when the image is cropped.

[Page top](#) 

Advanced Guide

Advanced Guide > Printing from a Computer > Printing with the Bundled Application Software > Easy-PhotoPrint Pro Settings > Saving Print Settings

Easy-PhotoPrint Pro

Saving Print Settings

You can save frequently used combinations of paper size, media type, color adjustment, etc. as custom profiles. Saved profiles can be loaded from a list. This allows you to print photos instantly with your favorite settings.

Click Add... in the Printer Settings window to display the Add to Profiles dialog box. Enter Name and Description, then click OK.

Parameter	Setting
Printer	Canon XXXX
Paper Size	A4
Media Type	Photo Paper Plus Glossy II
Paper Source	Rear Tray
Print Quality	Standard
Grayscale Photo	OFF
Color Balance	Cyan: 0 Magenta: 0 Yellow: 0
Brightness	0
Contrast	0
Color Mode	Enable ICC Profile

Important

- Enter up to 64 characters in Name.
- "Default" or "Custom" cannot be used for Name.
- Enter up to 256 characters in Description.

Note

- Click Edit/Delete... in the Printer Settings window to edit names and descriptions or delete profiles.

Advanced Guide

[Advanced Guide](#) > [Printing from a Computer](#) > [Printing with Other Application Software](#)

Printing with Other Application Software

- ➔ [Various Printing Methods](#)
- ➔ [Changing the Print Quality and Correcting Image Data](#)
- ➔ [Overview of the Printer Driver](#)

[Page top](#) ↑

Advanced Guide

[Advanced Guide](#) > [Printing from a Computer](#) > [Printing with Other Application Software](#) > [Various Printing Methods](#)

Various Printing Methods

- ➔ [Printing with Easy Setup](#)
- ➔ [Setting a Page Size and Orientation](#)
- ➔ [Setting the Number of Copies and Printing Order](#)
- ➔ [Setting the Stapling Margin](#)
- ➔ [Borderless Printing](#)
- ➔ [Fit-to-Page Printing](#)
- ➔ [Scaled Printing](#)
- ➔ [Page Layout Printing](#)
- ➔ [Poster Printing](#)
- ➔ [Booklet Printing](#)
- ➔ [Duplex Printing](#)
- ➔ [Stamp/Background Printing](#)
- ➔ [Saving a Stamp Setting](#)
- ➔ [Saving Image Data to be Used as a Background](#)
- ➔ [Printing an Envelope](#)
- ➔ [Front Feed Printing](#)
- ➔ [Displaying the Print Results before Printing](#)
- ➔ [Setting Paper Dimensions \(Custom Size\)](#)

[Page top](#) ↕

Advanced Guide

Advanced Guide > Printing from a Computer > Printing with Other Application Software > Various Printing Methods > Printing with Easy Setup

Printing with Easy Setup

A simple procedure that is necessary for printing data properly with this printer, is as follows:

1. Open the [printer driver setup window](#)
2. Select a frequently used profile

In Commonly Used Settings, select a printing profile suited for the purpose.

When you select a printing profile, the Additional Features, Media Type, and Printer Paper Size settings are automatically switched to the values that were preset.

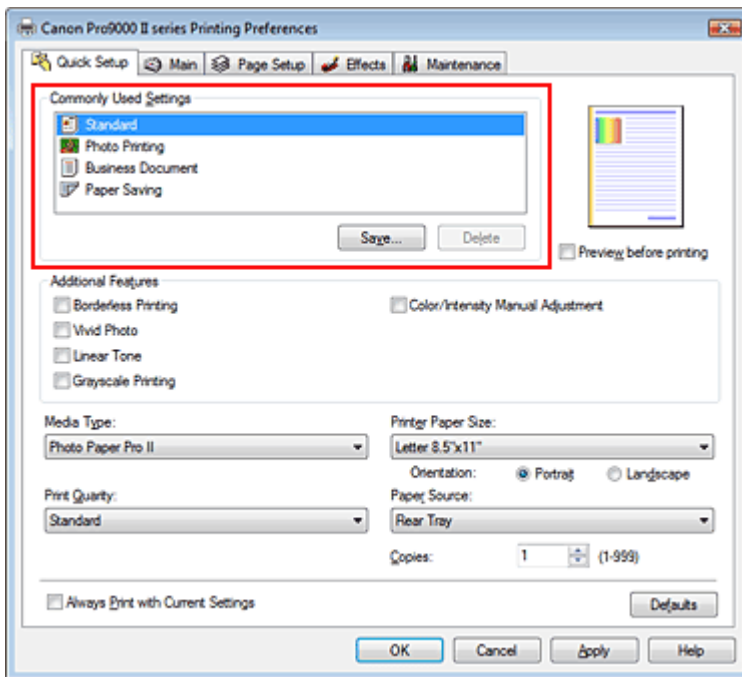

3. Select the print quality

Select High, Standard, or Fast for Print Quality.

Important

- Certain print quality levels cannot be selected depending on the settings of Media Type.

4. Complete the setup

Click OK.

When you execute print, the document is printed with settings suited for the purpose.

Important

- If you check the Always Print with Current Settings check box, all settings on the Quick Setup, Main, Page Setup, and Effects tabs are saved, and you can print with the same settings from the next time as well.
- Click Save... to register the specified settings. For instructions on registering settings, see "[Registering a Frequently Used Printing Profile](#)."

Advanced Guide

Advanced Guide > Printing from a Computer > Printing with Other Application Software > Various Printing Methods > Setting a Page Size and Orientation

Setting a Page Size and Orientation

The paper size and orientation are essentially determined by the application. If the page size and orientation set for Page Size and Orientation on the Page Setup tab are same as those set with the application, you do not need to select them on the Page Setup tab.

If you are not able to specify them with the application, the procedure for selecting a page size and orientation is as follows:

You can also set Page Size and Orientation on the Quick Setup tab.

1. Open the printer driver setup window

2. Select the paper size

Select a page size from the Page Size list on the Page Setup tab.

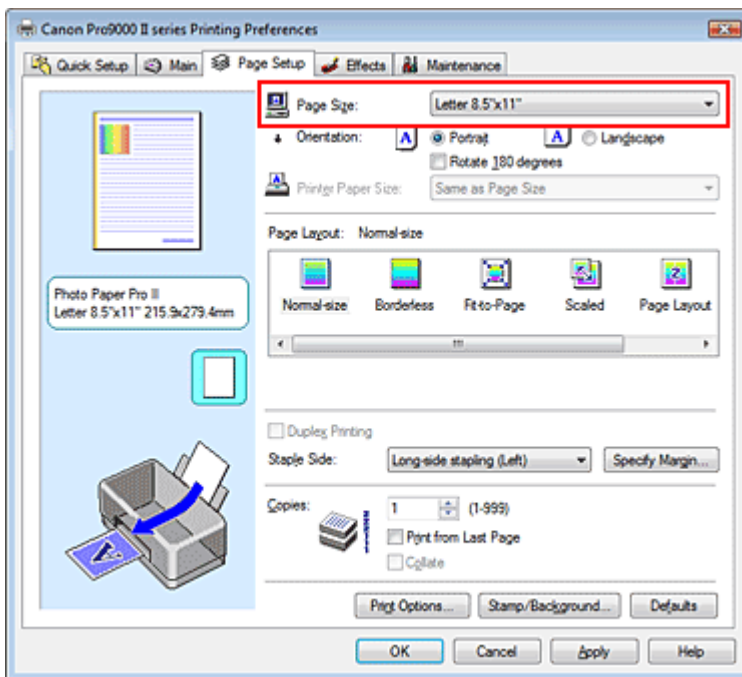

3. Select Orientation

Select Portrait or Landscape for Orientation. Check Rotate 180 degrees check box if you want to perform printing with the original being rotated 180 degrees.

4. Complete the setup

Click OK.

The document will be printed with the selected page size and the orientation.

Advanced Guide

Advanced Guide > Printing from a Computer > Printing with Other Application Software > Various Printing Methods > Setting the Number of Copies and Printing Order

Setting the Number of Copies and Printing Order

Default Setting

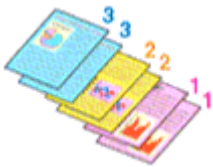

Print from Last Page

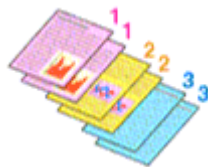

Collate

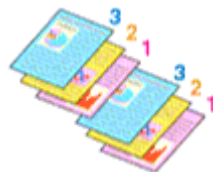

Print from Last Page + Collate

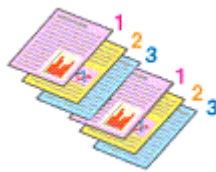

The procedure for specifying the number of copies and printing order is as follows:
You can also set the number of copies on the Quick Setup tab.

1. Open the **printer driver setup window**
2. Specify the number of copies to be printed

For Copies on the Page Setup tab, specify the number of copies to be printed.

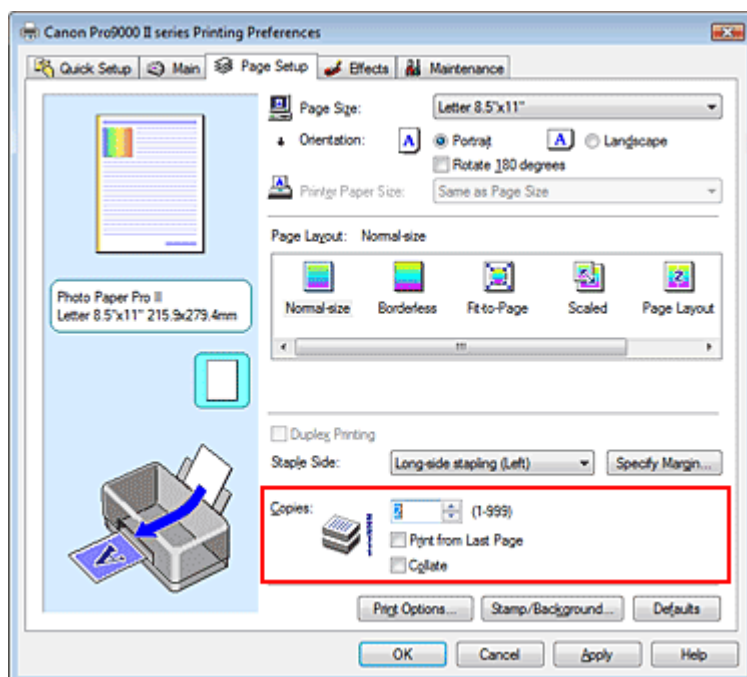

3. Specify the print sequence

Check the Print from Last Page check box if you want to print from the last page in order. If you do this, you do not need to sort pages into their correct order after printing.

4. Set up collated printing when you specify multiple copies in the Copies box

Check the Collate check box if you are specifying multiple copy together.
Uncheck this check box to print all pages with the same page number together.

5. Complete the setup

Click OK.

The specified number of copies will be printed with the specified printing order.

Important

- If the application software that you used to create the document has the same function, give priority to the printer driver settings. However, if the print results are not acceptable, specify the function settings on the application software. If you specify the number of copies and the printing order with both the application and this printer driver, the number of copies may be multiplied numbers of the two settings or the specified printing order may not be enabled.
- Print from Last Page and Collate appear grayed out and are unavailable if Booklet is selected for Page Layout.
- Print from Last Page appears grayed out and is unavailable if Poster is selected for Page Layout.

Note

- By setting both Print from Last Page and Collate, you can perform printing so that papers are collated one by one starting from the last page. These settings can be used in combination with Borderless, Normal-size, Fit-to-Page, Scaled, Page Layout, and Duplex Printing.

[Page top](#) 

Advanced Guide

Advanced Guide > Printing from a Computer > Printing with Other Application Software > Various Printing Methods > Setting the Stapling Margin

Setting the Stapling Margin

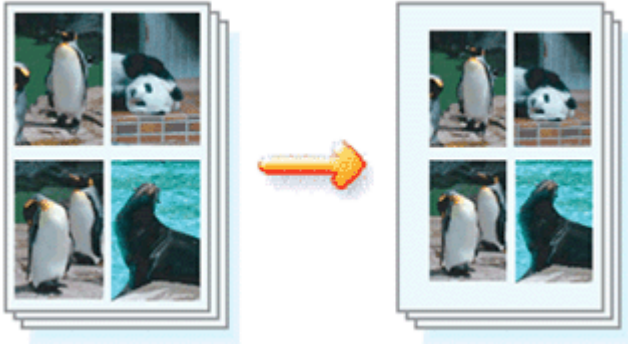

The procedure for setting the stapling direction and the width of the stapling margin is as follows:

1. Open the **printer driver setup window**
2. Specify the side to be stapled

Check the position of the stapling margin from Staple Side on the Page Setup tab.

The printer analyzes the Orientation and Page Layout settings, and automatically selects the best staple position. If you want to change the setting, select from the list.

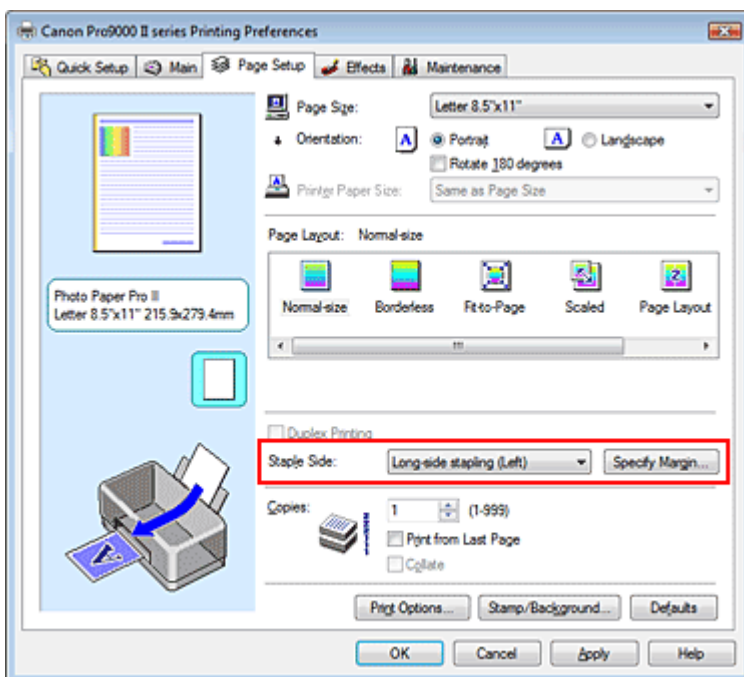

3. Set the margin width

If necessary, click Specify Margin... and set the width of the stapling margin, and then click OK.

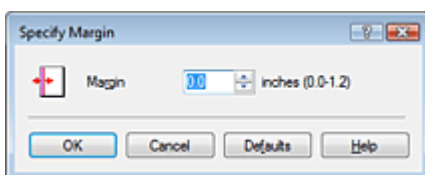

4. Complete the setup

Click OK on the Page Setup tab.

When you execute print, the data is printed with the specified staple side and margin.

 **Important**

- Staple Side and Specify Margin... appear grayed out and are unavailable when:
 - Borderless, Poster, or Booklet is selected for Page Layout.
 - Scaled is selected for Page Layout (If Duplex Printing is also selected, only Staple Side is selectable).

[Page top ↑](#)

Advanced Guide

Advanced Guide > Printing from a Computer > Printing with Other Application Software > Various Printing Methods > Borderless Printing

Borderless Printing

The borderless printing function allows you to print data without any margin by enlarging the data so that it extends slightly off the paper. Without the borderless printing function, a margin is provided around the printed data. If you want to print data such as a photo without providing any margin around it, select Borderless Printing.

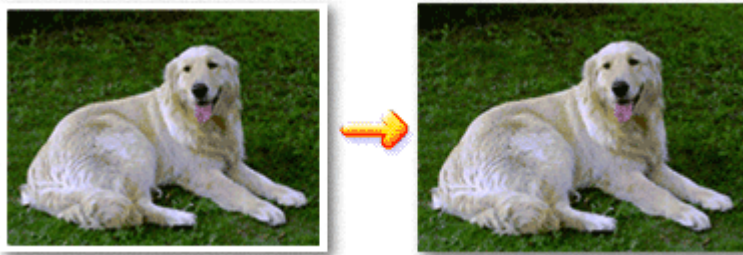

The procedure for performing borderless printing is as follows:

Setting Borderless Printing

1. Open the printer driver setup window

2. Set borderless printing

Select Borderless from the Page Layout list on the Page Setup tab.

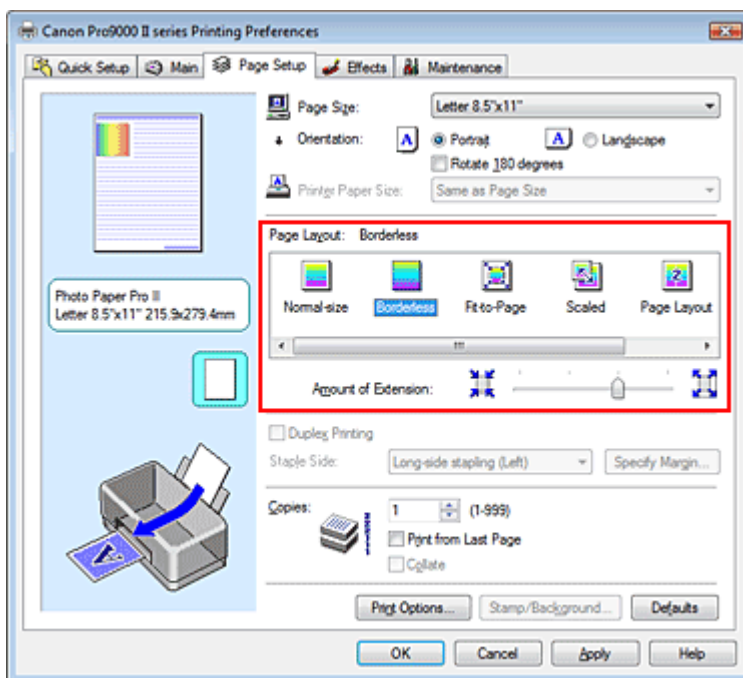

Click OK when the confirmation message appears.

When a message prompting you to change the media type appears, select a media type from the list and click OK.

3. Check the paper size

Check the Page Size list. If you want to change, select another page size from the list. The list displays only sizes that can be used for borderless printing.

4. Adjust the amount of extension from the paper

Adjust the amount of extension using the Amount of Extension slider as necessary.

Moving the slider to the right makes the amount larger and moving the slider to the left makes the amount smaller.

It is recommended to set the slider at the second position from the right for most cases.



Important

- If you set the slider at the rightmost position, the back side of the paper may become smudged.

5. Complete the setup

Click OK.

The data will be printed without any margins on the paper.

Important

- If a page size that cannot be used for borderless printing is selected, the size is automatically changed to the valid page sizes for borderless printing.
- You can execute borderless printing only when the following Media Type is selected on the Main tab.
 - Plain Paper
 - Photo Paper Plus Glossy II
 - Photo Paper Pro II
 - Photo Paper Pro Platinum
 - Photo Paper Plus Semi-gloss
 - Glossy Photo Paper
 - Matte Photo Paper
 - Ink Jet Hagaki
 - Hagaki
 - Other Photo Paper
- When Borderless is selected, the Printer Paper Size, Staple Side settings, and the Stamp/Background... button on the Page Setup tab appear grayed out and are unavailable.
- Print quality may deteriorate or the sheet may be stained at the top and bottom depending on the type of the media used.
- When the ratio of the height to the width differs greatly from the image data, a portion of the image may not be printed depending on the size of the media used.
In this case, crop the image data with an application software according to the paper size.

Expanding the Range of the Document to Print

Specifying a large amount of extension allows you to perform borderless printing with no problems. However, the portion of the document that extends off the paper range will not be printed. Subjects around the perimeter of a photo may not be printed.

Try borderless printing once. If you are not satisfied with the result of borderless printing, reduce the amount of extension. The extension amount becomes shorter as the Amount of Extension slider is moved to the left.

Important

- If the amount of extension is shortened, an unexpected margin may be produced on the print, depending on the size of the paper.

Note

- If the Amount of Extension slider is set to the leftmost position, image data will be printed in the full size.
- If Preview before printing is checked on the Main tab, you can confirm before printing whether there will be no border.

Advanced Guide

Advanced Guide > Printing from a Computer > Printing with Other Application Software > Various Printing Methods > Fit-to-Page Printing

Fit-to-Page Printing



The procedure for printing document, which is enlarged or reduced to fit to the page size, is as follows:

1. Open the printer driver setup window
2. Set fit-to-page printing

Select Fit-to-Page from the Page Layout list on the Page Setup tab.

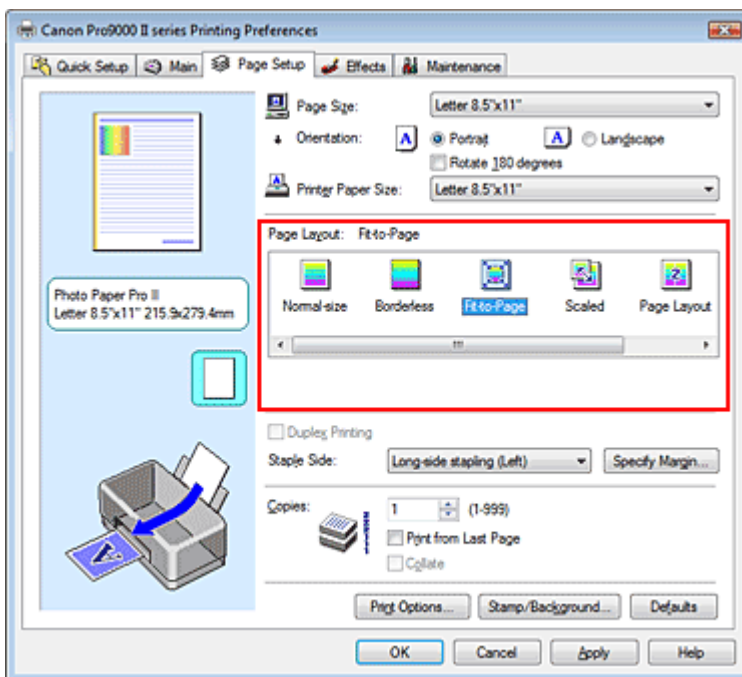

3. Select the paper size for the data

Using Page Size, select the page size that was set with your application.

4. Select the print paper size

Select the size of the paper loaded in the printer from the Printer Paper Size list.

If the printer paper size is smaller than the Page Size, the page image will be reduced. If the printer paper size is larger than the page size, the page image will be enlarged.

The current settings are displayed in the Settings Preview on the left side of the printer driver.

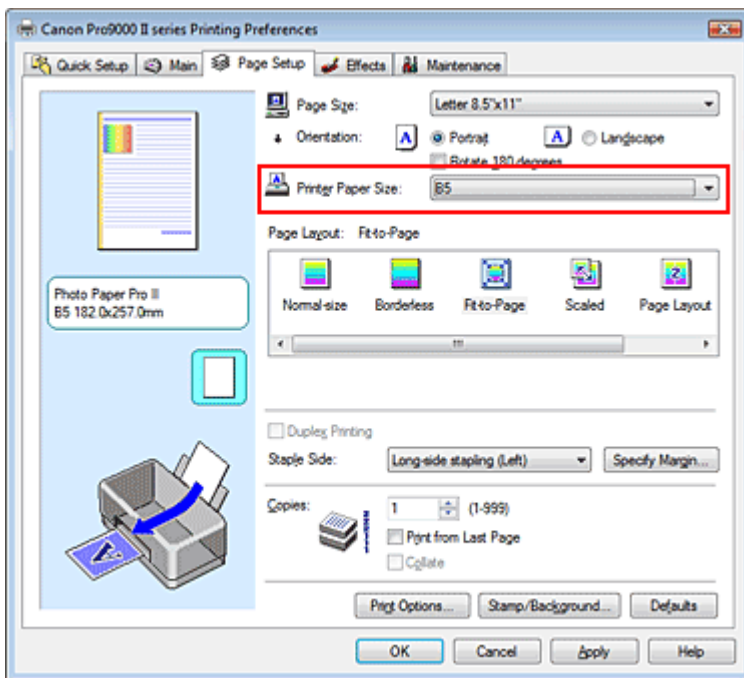

5. Complete the setup

Click OK.

When you execute print, the document will be enlarged or reduced to fit to the page size.

[Page top](#) ↑

Advanced Guide

Advanced Guide > Printing from a Computer > Printing with Other Application Software > Various Printing Methods > Scaled Printing

Scaled Printing



The procedure for printing a document with pages enlarged or reduced is as follows:

1. Open the **printer driver setup window**
2. Set scaled printing

Select Scaled from the Page Layout list on the Page Setup tab.

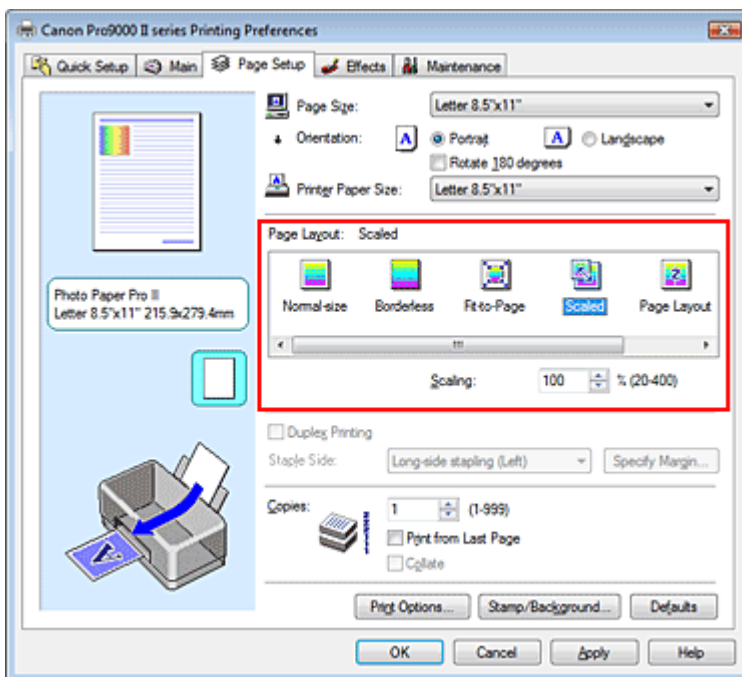

3. Select the paper size for the data

Using Page Size, select the page size that was set with your application.

4. Set the scaling rate by using one of the following methods:

- **Select a Printer Paper Size**

Select a printer paper size, which is different from the Page Size, from the Printer Paper Size list. If the printer paper size is smaller than the Page Size, the page image will be reduced. If the printer paper size is larger than the page size, the page image will be enlarged.

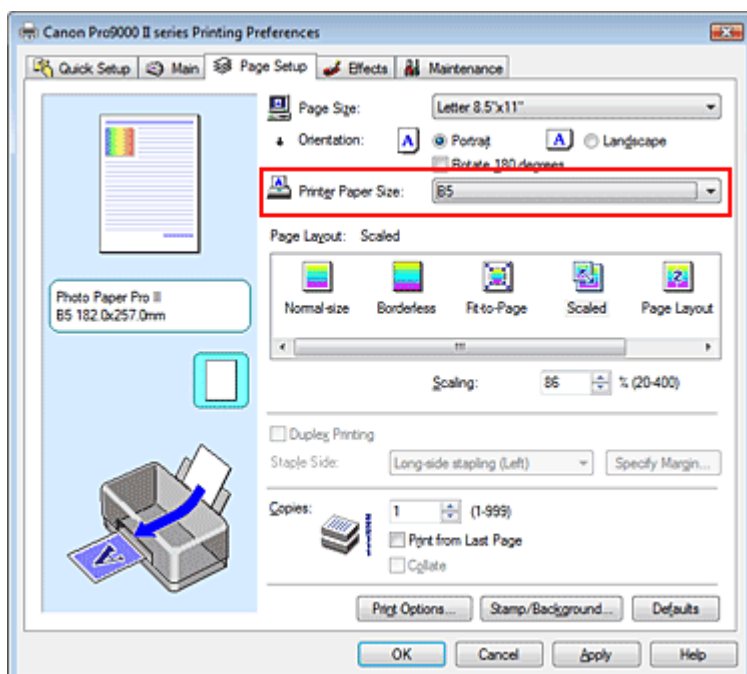

- **Specify a scaling factor**

Directly type in a value into the Scaling box.

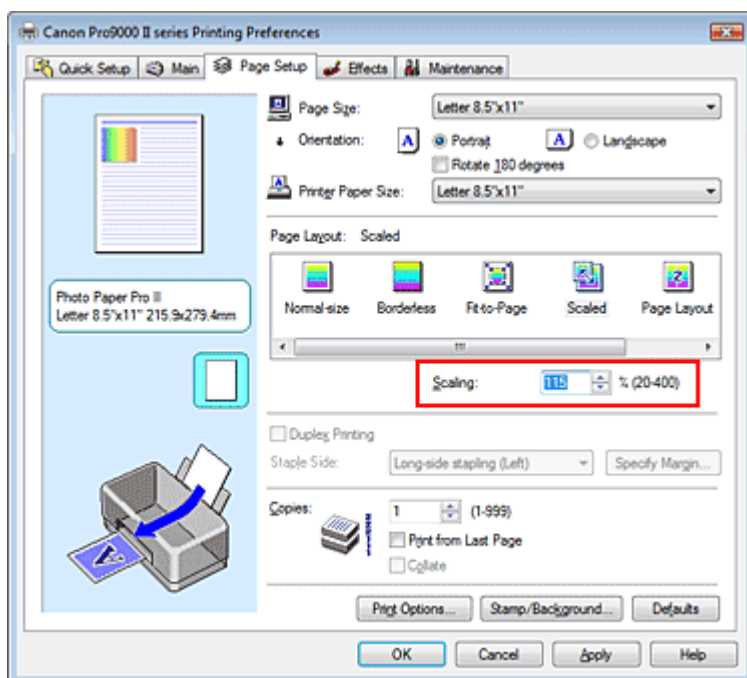

The current settings are displayed in the Settings Preview on the left side of the printer driver.

5. Complete the setup

Click OK.

When you execute print, the document will be printed with the specified scale.

Important

- If the application software with which you created the original has the scaled printing function, configure the settings on your application software. You do not need to also configure the same setting in the printer driver.
- When Scaled is selected, the Staple Side list box appears grayed out and is unavailable (when Duplex Printing is not selected).

Note

- Selecting Scaled changes the printable area of the document.

Advanced Guide

Advanced Guide > Printing from a Computer > Printing with Other Application Software > Various Printing Methods > Page Layout Printing

Page Layout Printing

The page layout printing function allows you to print more than one page image on a single sheet of paper.

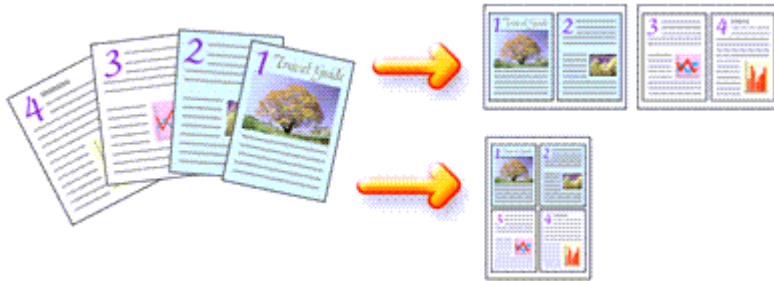

The procedure for performing page layout printing is as follows:

1. Open the **printer driver setup window**
2. Set page layout printing

Select Page Layout from the Page Layout list on the Page Setup tab.

The current settings are displayed in the Settings Preview on the left side of the printer driver.

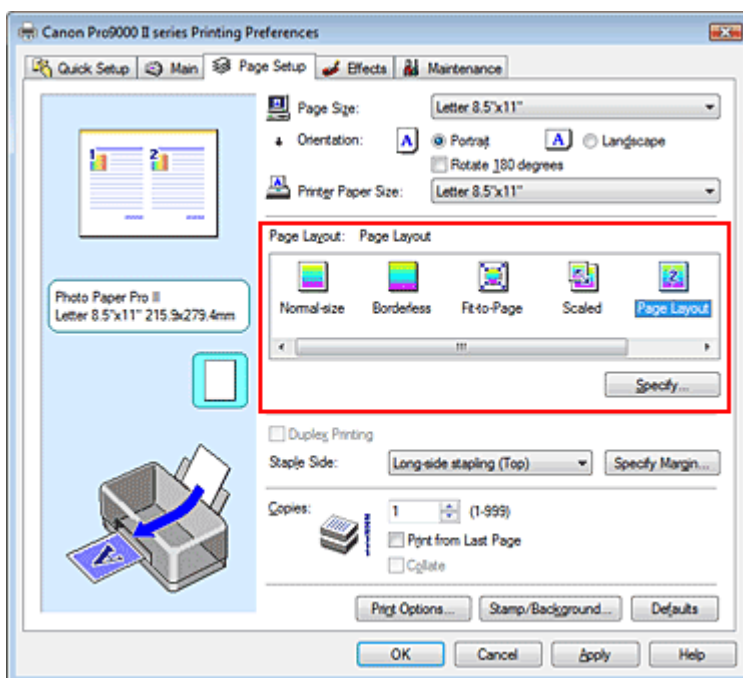

3. Select the print paper size

Select the size of the paper loaded in the printer from the Printer Paper Size list.

Now you have finished setting the layout of the document from left to right.

4. Set the number of pages to be printed on one sheet and the page sequence

If necessary, click Specify..., specify the following settings in the Page Layout Printing dialog box, and click OK.

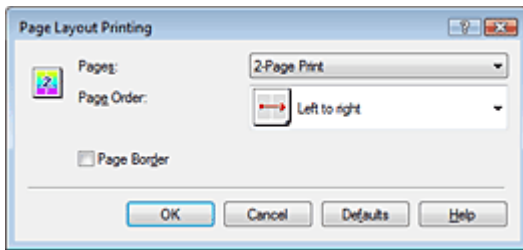
**Pages**

To increase the number of pages to be included on a single sheet of paper, select a desired number of pages from the list.

Page Order

To change the page arrangement order, select an icon from the list to change the page placement order.

Page Border

To print a page border around each document page, check this check box.

5. Complete the setup

Click OK on the Page Setup tab.

When you execute print, the specified number of pages will be arranged on each sheet of paper in the specified order.

[Page top](#) ↑

Advanced Guide

Advanced Guide > Printing from a Computer > Printing with Other Application Software > Various Printing Methods > Poster Printing

Poster Printing

The poster printing function allows you to enlarge image data, divide it into several pages, and print these pages on separate sheets of paper. When the pages are pasted together, they form a large print like a poster.

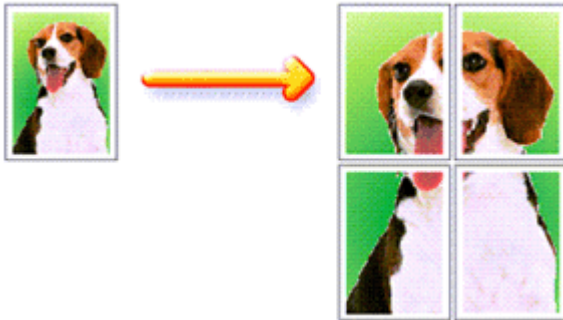

The procedure for performing poster printing is as follows:

Setting Poster Printing

1. Open the printer driver setup window
2. Set poster printing

Select Poster from the Page Layout list on the Page Setup tab.

The current settings are displayed in the Settings Preview on the left side of the printer driver.

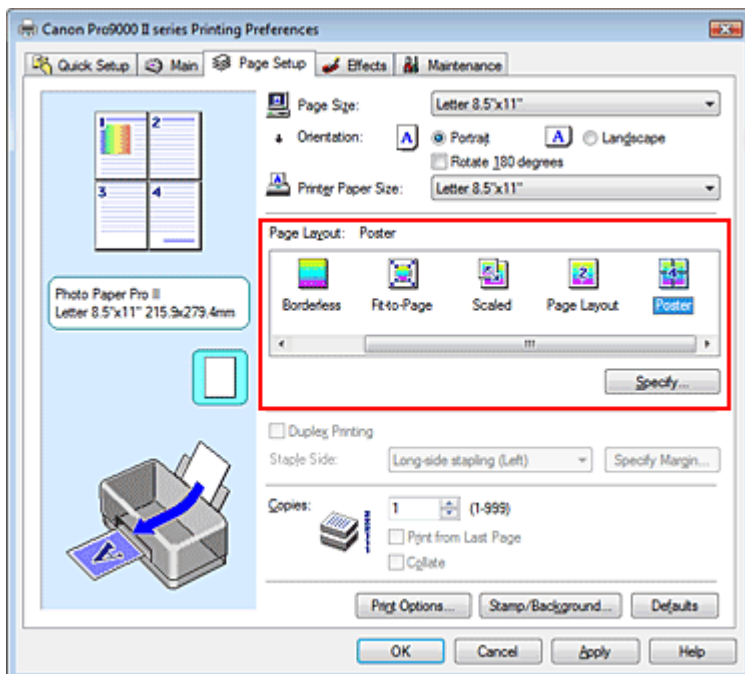

3. Select the print paper size

Select the size of the paper loaded in the printer from the Printer Paper Size list. Now you have finished setting 2 by 2-page poster printing.

4. Set the number of image divisions and the pages to be printed.

If necessary, click Specify..., specify the following settings in the Poster Printing dialog box, and then click OK.

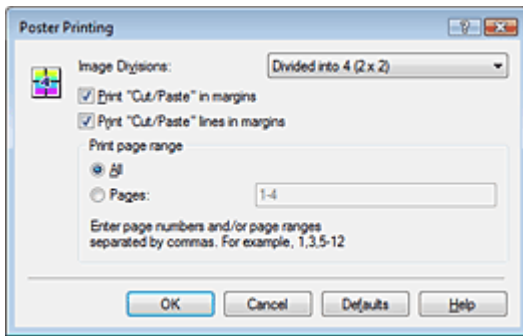

Image Divisions

Select the number of divisions (vertical x horizontal) from the Image Divisions list. As the number of divisions increases, the number of sheets used for printing increases, allowing you to create a larger poster.

Print "Cut/Paste" in margins

To leave out words "Cut" and "Paste", uncheck this check box.

Important

- This feature is unavailable when the 64-bit printer driver is used.

Print "Cut/Paste" lines in margins

To leave out cut lines, uncheck this check box.

Pages

To reprint only specific pages, enter the page number you want to print. To print multiple pages, specify by separating the pages with commas or entering a hyphen between the page numbers.

Note

- You can also specify the print range by clicking the pages in the setup preview.

5. Complete the setup

Click OK on the Page Setup tab.

When you execute print, the document will be divided into several pages during printing.

After all poster pages have been printed, paste the pages together to create a poster.

Printing Only Specific Pages

If ink becomes faint or runs out during printing, you can print the pages you still need, by following the procedure below:

1. Set the print range

In the Settings Preview on the left of the Page Setup tab, click the pages that do not need to be printed.

The pages that were clicked are deleted, and only the pages to be printed are displayed.

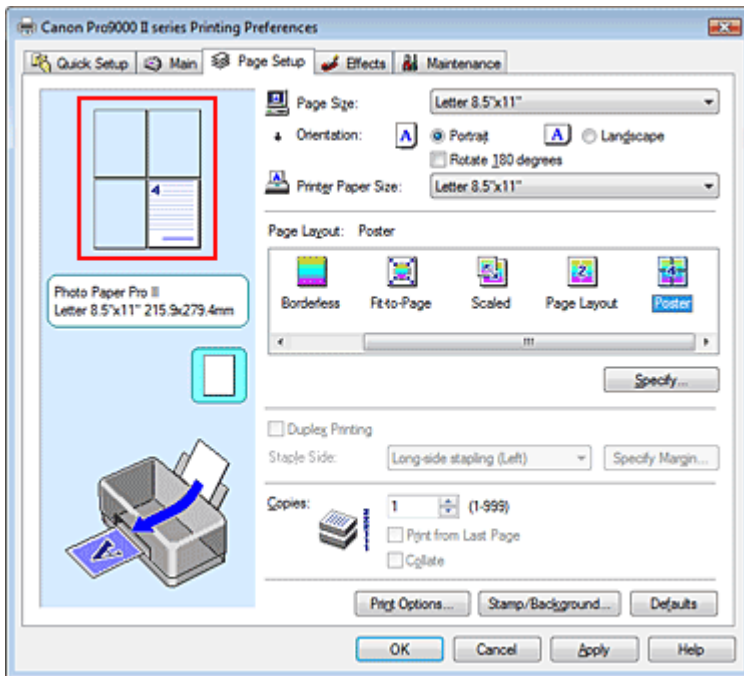

Note

- Click the deleted pages to display them again.
- Right-click the Settings Preview to select Print all pages or Delete all pages.

2. Complete the setup

After completing the page selection, click OK.

When you execute print, only specified pages will be printed.

Important

- When Poster is selected, the Duplex Printing and Print from Last Page check boxes and the Staple Side list box appear grayed out and are unavailable.
- Since poster printing enlarges the document when printing it, the print results may become coarse.

Advanced Guide

Advanced Guide > Printing from a Computer > Printing with Other Application Software > Various Printing Methods > Booklet Printing

Booklet Printing

The booklet printing function allows you to print data for a booklet. Data is printed on both sides of the paper. This type of printing ensures that pages can be collated properly, in page number order, when the printed sheets are folded and stapled at the center.

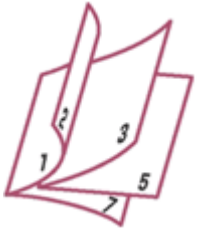

The procedure for performing booklet printing is as follows:

1. Open the printer driver setup window
2. Set booklet printing

Select Booklet from the Page Layout list on the Page Setup tab.

The current settings are displayed in the Settings Preview on the left side of the window.

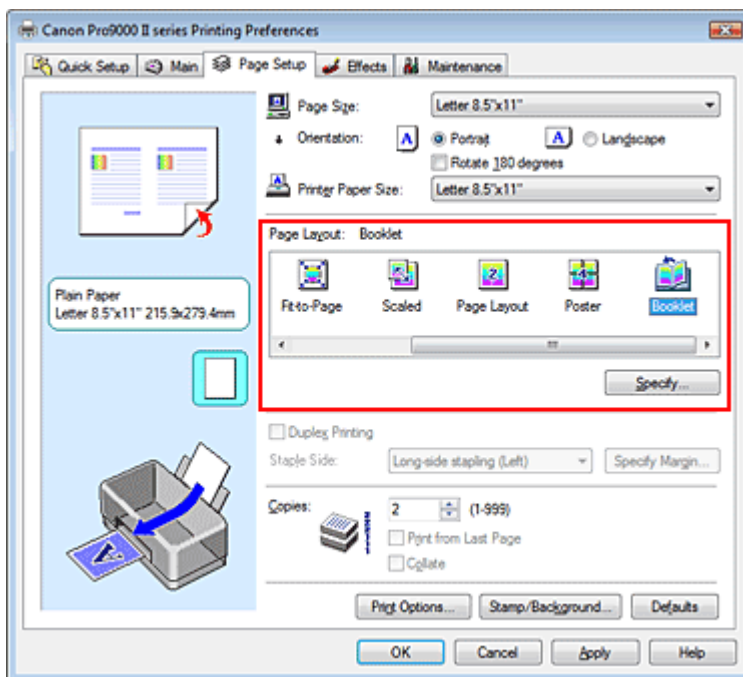

3. Select the print paper size

Select the size of the paper loaded in the printer from the Printer Paper Size list.

4. Set the margin for stapling and the margin width

Click Specify..., specify the following settings in the Booklet Printing dialog box, and then click OK.

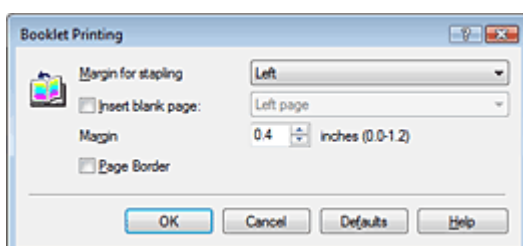

Margin for stapling

Select which side the stapling margin should be on when the booklet is completed.

Insert blank page

To leave one side of a sheet blank, check Insert blank page check box, and select the page to be left blank.

Margin

Enter the margin width. The specified width from the center of the sheet becomes the margin for one page.

Page Border

To print a page border around each document page, check the Page Border check box.

5. Complete the setup

Click OK on the Page Setup tab.

When you execute print, the document will be printed on one side of a sheet of paper. When the printing of one side is complete, set the paper correctly by following the message and click OK.

When the printing of the other side is complete, fold the paper at the center of the margin and make a booklet.

 **Important**

- Booklet cannot be selected when a media type other than Plain Paper is selected for Media Type.
- When Booklet is selected, Duplex Printing, Staple Side, Print from Last Page, and Collate appear grayed out and are unavailable.

 **Note**

- The stamp and background are not printed on blank sheets inserted with the Insert blank page function of Booklet Printing.

Advanced Guide

Advanced Guide > Printing from a Computer > Printing with Other Application Software > Various Printing Methods > Duplex Printing

Duplex Printing

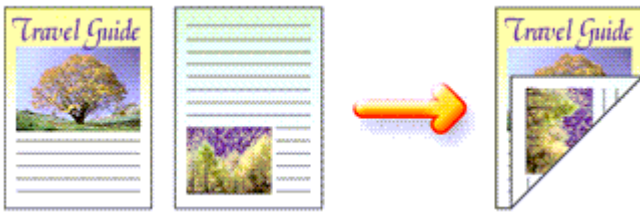

The procedure for printing data on both sides of a sheet of paper is as follows:
You can also set duplex printing in Additional Features on the Quick Setup tab.

1. Open the **printer driver setup window**
2. Set duplex printing

Check the Duplex Printing check box on the Page Setup tab.

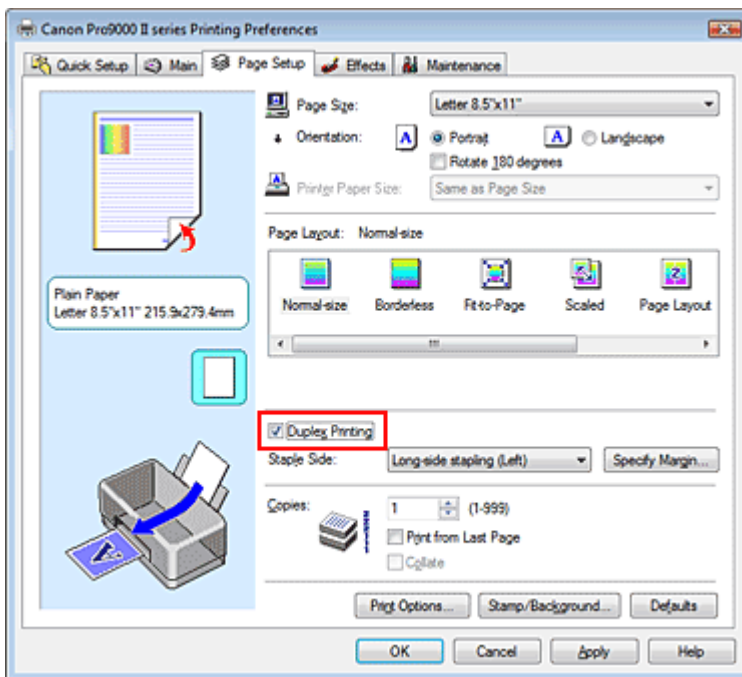

3. Select the layout

Select Normal-size (or Fit-to-Page, Scaled, or Page Layout) from the Page Layout list.

4. Specify the side to be stapled

The printer analyzes the Orientation and Page Layout settings, and automatically selects the best Staple Side. If you want to change the setting, select another value from the list.

5. Set the margin width

If necessary, click Specify Margin... and set the width of the stapling margin, and then click OK.

6. Complete the setup

Click OK on the Page Setup tab.

When you execute print, the document will be printed on one side of a sheet of paper. When the printing of one side is complete, set the paper correctly by following the message and click OK. The document will be printed on the opposite side.

 **Important**

- Duplex Printing is unavailable when:
 - A media type other than Plain Paper is selected from the Media Type list.
 - Poster is selected from the Page Layout list.
- When Booklet is selected from the Page Layout list, Duplex Printing and Staple Side appear grayed out and are unavailable.

 **Note**

- If the back side of the paper becomes smudged during duplex printing, perform Bottom Plate Cleaning in the Maintenance tab.

[Page top ↑](#)

Advanced Guide

Advanced Guide > Printing from a Computer > Printing with Other Application Software > Various Printing Methods > Stamp/Background Printing

Stamp/Background Printing

This feature is unavailable when the 64-bit printer driver is used.

The Stamp function allows you to print a stamp text or a bitmap over or behind document data. It also allows you to print date, time and user name. The Background function allows you to print a light illustration behind the document data.

The procedure for performing stamp/background printing is as follows:

Printing a Stamp

"CONFIDENTIAL," "IMPORTANT," and other stamps that are used often in companies are pre-registered.

1. Open the [printer driver setup window](#)
2. Click Stamp/Background... on the Page Setup tab

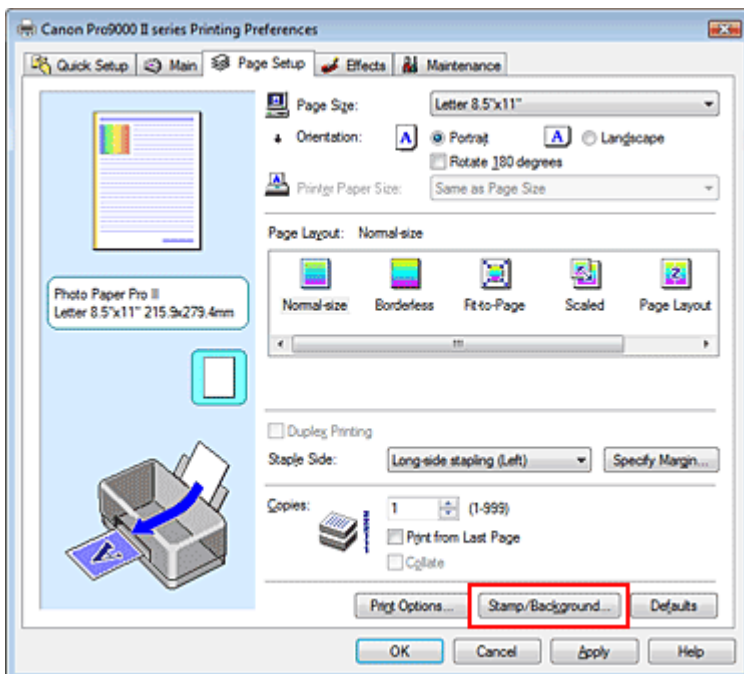

The Stamp/Background dialog box opens.

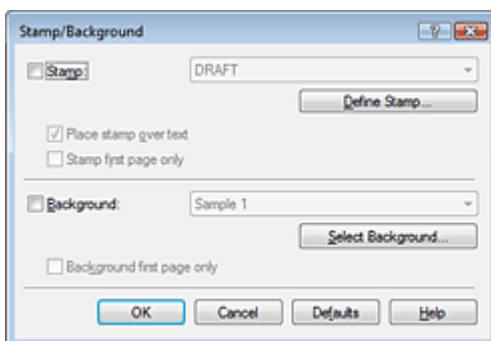

3. Select a stamp

Check the Stamp check box, and select a desired stamp from the list.

The current settings are displayed in the Settings Preview on the left side of the Page Setup tab.

4. Set the stamp details

If necessary, complete the following settings, and then click OK.

Place stamp over text

To print the stamp on the front of the document, check this check box.

 **Note**

- The stamp is given priority because the stamp is printed over the document data in the sections where the stamp and the document data overlap. If the Place stamp over text check box is unchecked, the stamp is printed behind the document data and may be hidden in the overlapping sections depending on the application used.

Stamp first page only

To print the stamp only on the first page, check this check box.

Define Stamp... button

To change the stamp text, bitmap, or position, click this (refer to Saving a Stamp Setting).

5. Complete the setup

Click OK on the Page Setup tab.

When you execute print, the data is printed with the specified stamp.

Printing a Background**1. Select the background for which the settings are to be changed**

Two bitmap files are pre-registered as samples.

2. Click Stamp/Background... on the Page Setup tab

The Stamp/Background dialog box opens.

3. Select the background

Check the Background check box, and select a desired background from the list.

The current settings are displayed in the Settings Preview on the left side of the Page Setup tab.

4. Set the background details

If necessary, complete the following settings, and then click OK.

Background first page only

To print the background only on the first page, check this check box.

Select Background... button

To use another bitmap file or change the layout or density of a background, click this (refer to [Saving Image Data to be Used as a Background](#)).

5. Complete the setup

Click OK on the Page Setup tab.

When you execute print, the data is printed with the specified background.

 **Important**

- When Borderless is selected, the Stamp/Background... button appears grayed out and is unavailable.

 **Note**

- The stamp and background are not printed on blank sheets inserted with the Insert blank page function of Booklet Printing.

Related Topics

➔ [Saving a Stamp Setting](#)

➔ [Saving Image Data to be Used as a Background](#)



Advanced Guide

Advanced Guide > Printing from a Computer > Printing with Other Application Software > Various Printing Methods > Stamp/Background Printing > Saving a Stamp Setting

Saving a Stamp Setting

This feature is unavailable when the 64-bit printer driver is used.

You can create and save a new stamp. You can also change and register some of the settings of an existing stamp. Unnecessary stamps can be deleted at any time.

The procedure for registering a new stamp is as follows:

Registering a New Stamp

1. Open the [printer driver setup window](#)
2. Click Stamp/Background... on the Page Setup tab

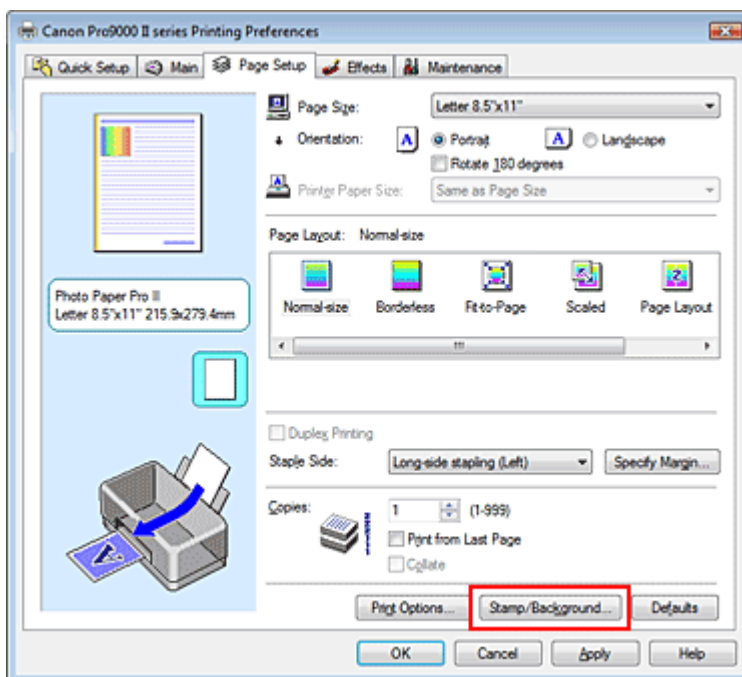

The Stamp/Background dialog box opens.

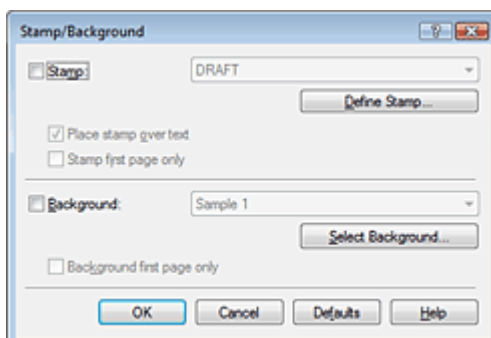

3. Click Define Stamp...

The Stamp Settings dialog box opens.

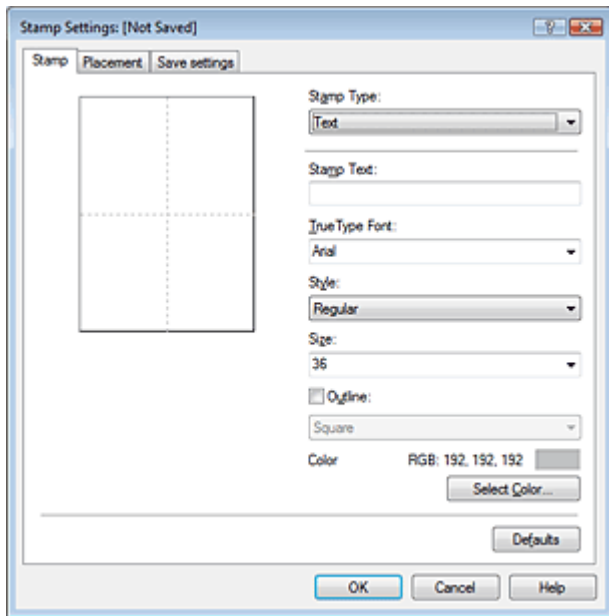

4. Configure the stamp while viewing the preview window

- **Stamp tab**

Select Text, Bitmap, or Date/Time/User Name for Stamp Type.

- For Text registration, the characters must already be entered in Stamp Text. Change the TrueType Font, Style, Size, and Outline settings, as necessary. You can select the color of the stamp by clicking Select Color....
- For Bitmap, click Select File... and select the bitmap file (.bmp) to be used. Change the settings of the Size and Transparent white area if necessary.
- For Date/Time/User Name, the creation date/time and user name of the printed object are displayed in Stamp Text. Change the settings of TrueType Font, Style, Size, and Outline, if necessary. You can select the color of the stamp by clicking Select Color....

Important

- Stamp Text appears grayed out and is unavailable if Date/Time/User Name is selected.

- **Placement tab**

Select the stamp position from the Position list. You can also select Custom from the Position list and specify coordinates for X-Position and Y-Position.

You can also change the stamp position by dragging the stamp in the preview window.

To change the stamp position angle, type a value in the Orientation box directly.

5. Save the stamp

Click the Save settings tab and enter a new stamp title in the Title box, and then click Save.

Click OK when the confirmation message appears.

6. Complete the setup

Click OK. The Stamp/Background dialog box opens again.

The registered title appears in the Stamp list.

Changing and Registering Some of Stamp Settings

1. Select the stamp for which the settings are to be changed

Check the Stamp check box in the Stamp/Background dialog box, and then select the title of the stamp to be changed from the Stamp list.

2. Click Define Stamp...

The Stamp Settings dialog box opens.

3. Configure the stamp while viewing the preview window**4. Save the stamp**

Click Save overwrite on the Save settings tab.

If you want to save the stamp with a different title, type a new title in the Title box and click Save.

Click OK when the confirmation message appears.

5. Complete the setup

Click OK. The Stamp/Background dialog box opens again.

The registered title appears in the Stamp list.

Deleting an Unnecessary Stamp**1. Click Define Stamp... in the Stamp/Background dialog box**

The Stamp Settings dialog box opens.

2. Select the stamp to be deleted

Select the title of the stamp you want to delete from the Stamps list on the Save settings tab. Then click Delete.

Click OK when the confirmation message appears.

3. Complete the setup

Click OK. The Stamp/Background dialog box opens again.



Advanced Guide

Advanced Guide > Printing from a Computer > Printing with Other Application Software > Various Printing Methods > Stamp/Background Printing > Saving Image Data to be Used as a Background

Saving Image Data to be Used as a Background

This feature is unavailable when the 64-bit printer driver is used.

You can select a bitmap file and save it as a new background. You can also change and register some of the settings of an existing background. An unnecessary background can be deleted at any time.

The procedure for registering image data to be used as a background is as follows:

Registering Image Data to be Used as a Background

1. Open the [printer driver setup window](#)
2. Click Stamp/Background... on the Page Setup tab

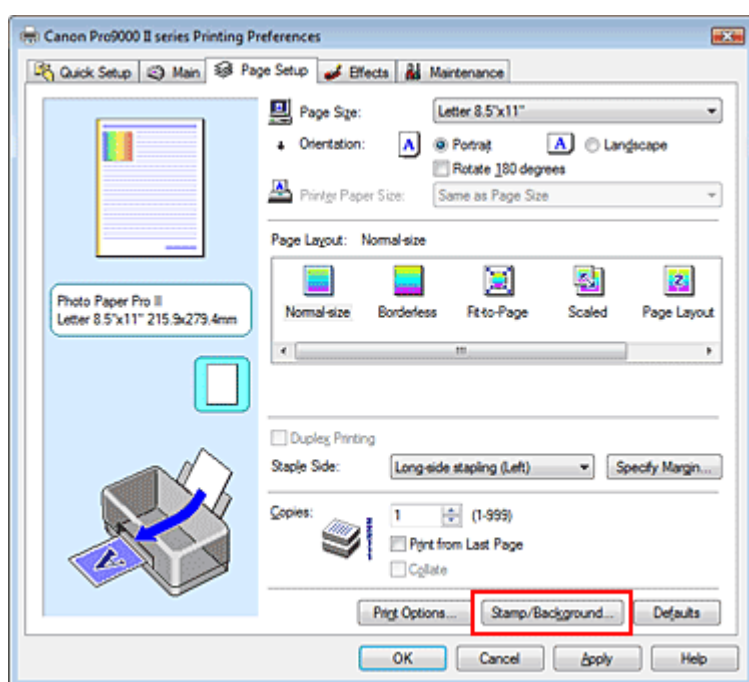

The Stamp/Background dialog box opens.

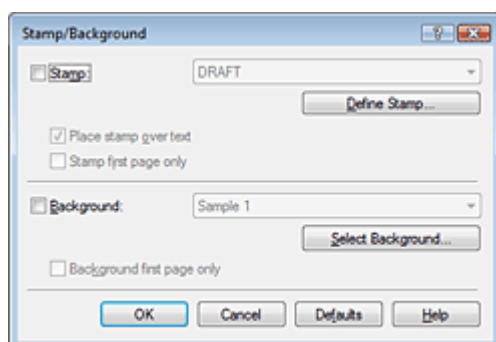

3. Click Select Background...

The Background Settings dialog box opens.

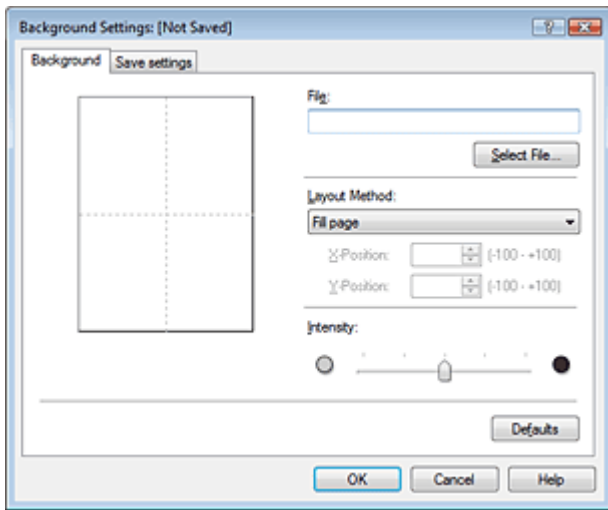

4. Select the image data to be registered to the background
Click Select File.... Select the target image data (bitmap file), and then click Open.
5. Specify the following settings while viewing the preview window

Layout Method

Select how the background image data is to be placed.

When Custom is selected, you can set coordinates for X-Position and Y-Position.

You can also change the background position by dragging the image in the preview window.

Intensity

Set the intensity of the background image data with the Intensity slider. To lighten the background, move the slider to the left. To darken the background, move the slider to the right. To print the background at the original bitmap intensity, move the slider to the rightmost position.

6. Save the background
Click the Save settings tab and enter a new stamp title in the Title box, and then click Save.
Click OK when the confirmation message appears.
7. Complete the setup
Click OK. The Stamp/Background dialog box opens again.
The registered title appears in the Background list.

Changing and Saving Some Background Settings

1. Select the background for which the settings are to be changed
Check the Background check box in the Stamp/Background dialog box, and then select the title of the background you want to change from the Background list.
2. Click Select Background...
The Background Settings dialog box opens.
3. While viewing the preview, set the items on the Background tab
4. Save the background
Click Save overwrite on the Save settings tab. If you want to save the background with a different title, type a new title in the Title box and click Save.
Click OK when the confirmation message appears.
5. Complete the setup
Click OK. The Stamp/Background dialog box opens again.
The registered title appears in the Background list.

Deleting an Unnecessary Background

1. Click Select Background... in the Stamp/Background dialog box

The Background Settings dialog box opens.

2. Select the background to be deleted

Select the title of the background you want to delete from the Backgrounds list on the Save settings tab, and then click Delete.

Click OK when the confirmation message appears.

3. Complete the setup

Click OK. The Stamp/Background dialog box opens again.



[Page top](#) ↑

Advanced Guide

Advanced Guide > Printing from a Computer > Printing with Other Application Software > Various Printing Methods > Printing an Envelope

Printing an Envelope

For details on how to load an envelope into the printer, refer to "Loading Paper in the Rear Tray" in the manual: Basic Guide.

The procedure for performing envelope printing is as follows:

1. Load an envelop into the printer

Fold down the envelope flap.

Orient the envelope so that the flap is on the left and the folded surface is facing down.

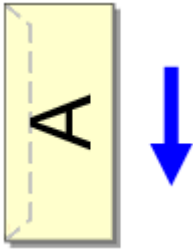

2. Open the printer driver setup window

3. Select the media type

Select Envelope from the Media Type list on the Main tab.

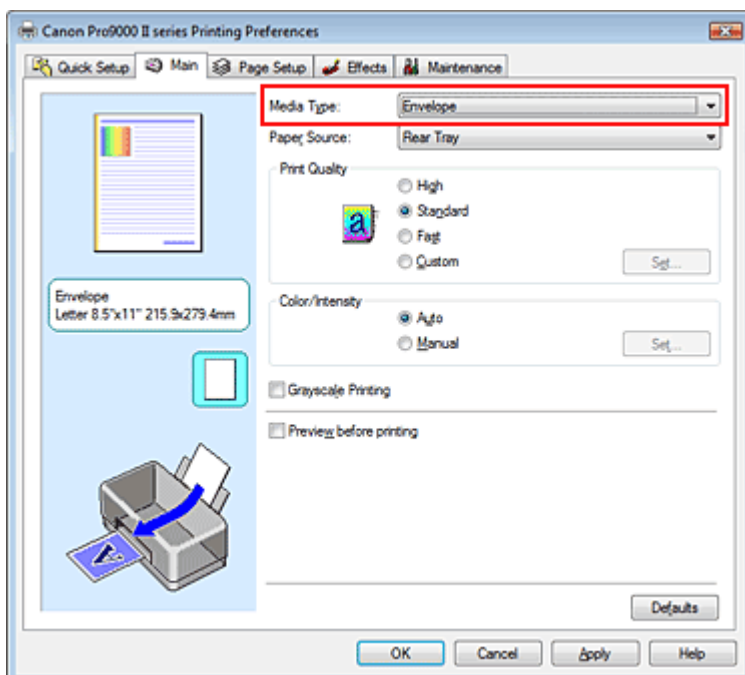

4. Select the paper size

Click the Page Setup tab, and select Youkei 4, Youkei 6, Comm.Env. #10, or DL Env. for Page Size.

5. Select the landscape for orientation

To print the addressee horizontally, select Landscape for Orientation.

6. Complete the setup

Click OK.

When you execute print, the information is printed on the envelope.

Advanced Guide

Advanced Guide > Printing from a Computer > Printing with Other Application Software > Various Printing Methods > Front Feed Printing

Front Feed Printing

If you are printing on thick paper such as art paper, feed the paper from the front tray of the printer. For instructions on setting up paper in the front tray, see the user's manual.

The procedure for printing by feeding paper from the front tray is as follows:

1. Open the [printer driver setup window](#)
2. Select the media type

On the Main tab, for Media Type, select the media type to be loaded in the front tray. Click OK when the confirmation message saying the paper source has been changed appears. Then the Paper Source changes to the Front Tray.

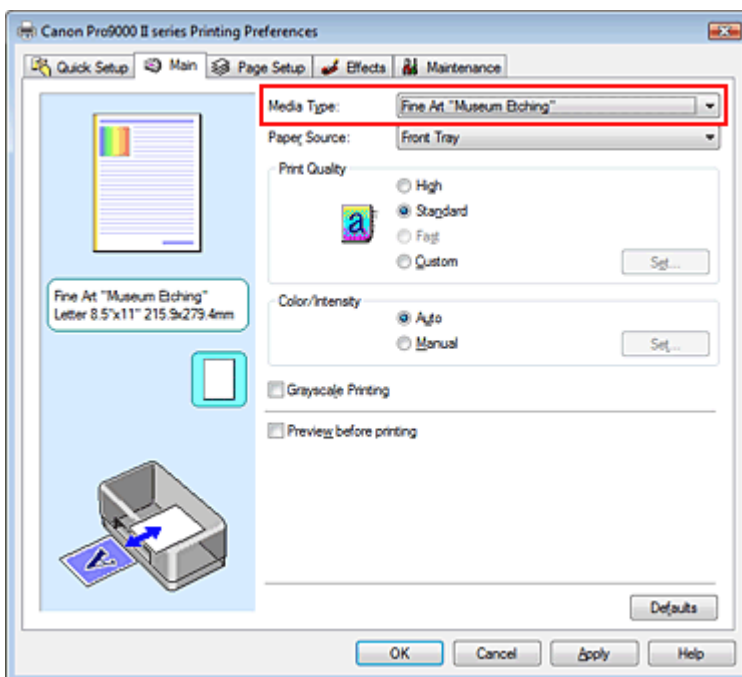

3. Select the paper source

Select Front Tray from the Paper Source list on the Main tab.

4. Select the paper size

Click the Page Setup tab, and for Page Size, select the paper size that was set with the application software.

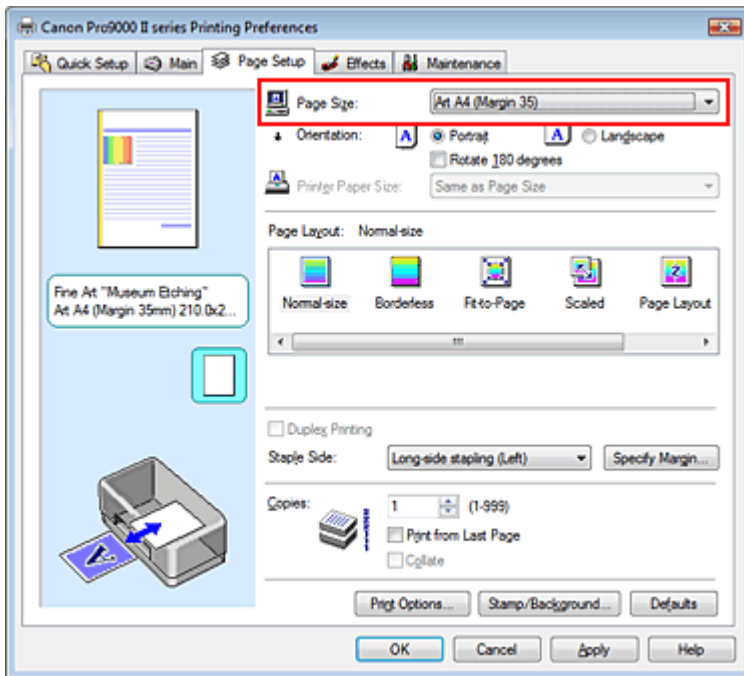

Note

- When Fine Art "Photo Rag", Fine Art "Museum Etching", Fine Art Premium Matte, Other Fine Art Paper, Canvas, or Board Paper is selected for Media Type on the Main tab, select Art XX (Margin 35) from the Page Size list.

5. Complete the setup

Click OK.

When you execute print, the printer starts printing by feeding paper from the front tray.

Load the paper in the front tray as instructed by the displayed message.

Important

- When Fine Art "Museum Etching", Fine Art Premium Matte, Canvas, or Board Paper is selected for Media Type on the Main tab, Paper Source is set to Front Tray and cannot be changed.
- If Envelope is selected for Media Type on the Main tab, front-feed printing cannot be executed.
- If L 89x127mm was selected for Page Size on the Page Setup tab, front feed printing cannot be executed.
- When Duplex Printing is selected for Page Layout on the Page Setup tab, Front Feed Printing cannot be performed.
- If 14"x17" 36x43cm was selected for Page Size on the Page Setup tab, always select Front Tray for Paper Source.

Note

- Canon IJ Status Monitor can display guidelines for Front Feed Printing. Display the Status Monitor by clicking View Printer Status... on the Maintenance tab, click Display Guide Message in the Option menu, and make sure that Front Feed Printing is checked. The instruction guide is displayed when you use Front Feed Printing.

Advanced Guide

Advanced Guide > Printing from a Computer > Printing with Other Application Software > Various Printing Methods > Displaying the Print Results before Printing

Displaying the Print Results before Printing

You can display and check the print result before printing.

The procedure for displaying the print result before printing is as follows:

You can also set the print results display on the Quick Setup tab.

1. Open the [printer driver setup window](#)
2. Set the preview

Check the Preview before printing check box on the Main tab.

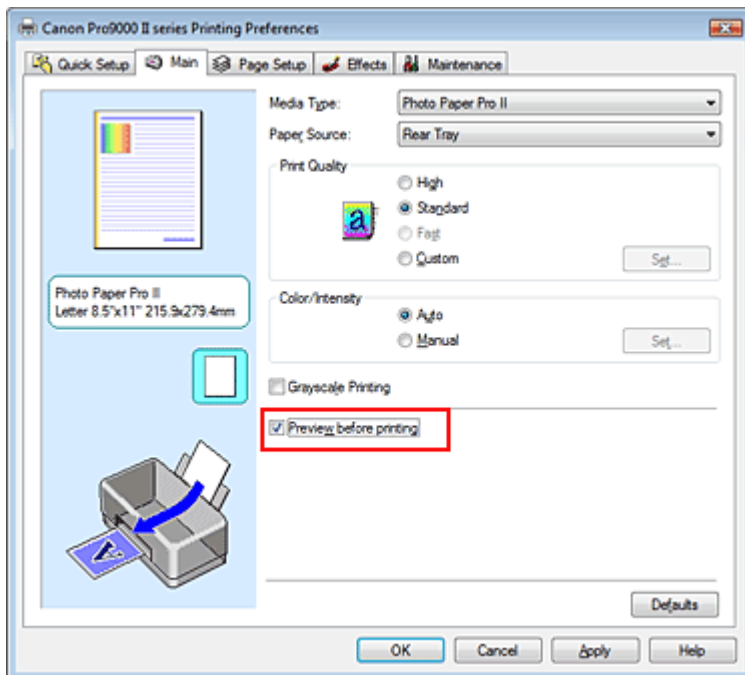

3. Complete the setup

Click OK.

The Canon IJ Preview will start and the print result will be displayed before printing.

Related Topic

➔ [Canon IJ Preview](#)

Advanced Guide

Advanced Guide > Printing from a Computer > Printing with Other Application Software > Various Printing Methods > Setting Paper Dimensions (Custom Size)

Setting Paper Dimensions (Custom Size)

You can specify the height and width of paper if its size cannot be selected in Page Size. Such a paper size is called a custom size.

The procedure for specifying a custom size is as follows:

You can also set a custom size in Printer Paper Size on the Quick Setup tab.

1. Set the custom size in the application software

On your application's paper size feature, specify your custom size.

Important

- If the application software that created the document has a function for specifying the height and width values, use the application software to set the values. If the application software does not have such a function or if the document does not print correctly, use the printer driver to set the values.

2. Open the printer driver setup window

3. Select the paper size

Select Custom... for Page Size on the Page Setup tab.

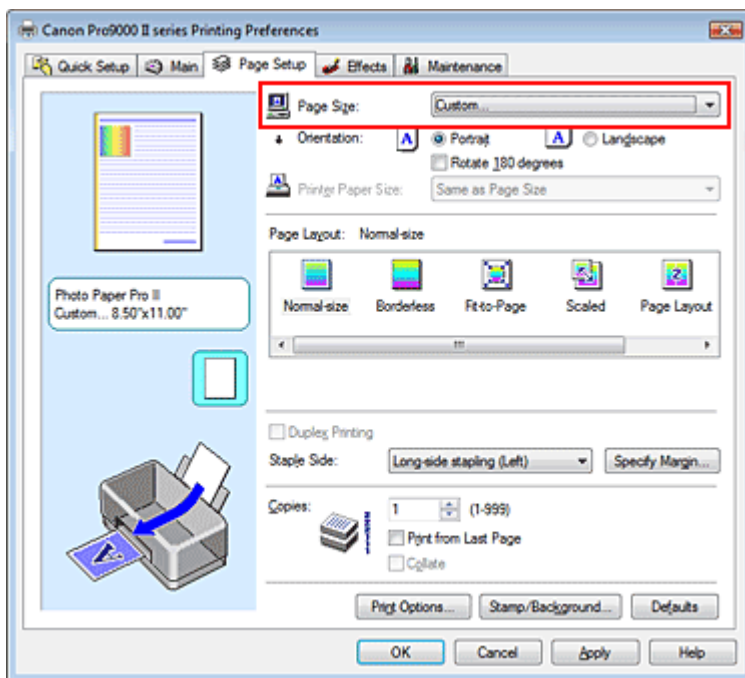

The Custom Paper Size dialog box opens.

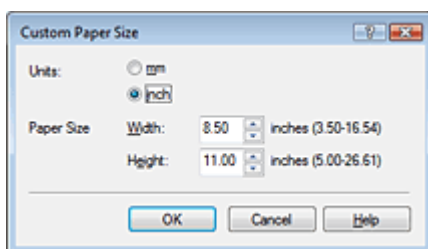

4. Set the custom size in the application software

Specify Units, and enter the Width and Height of the paper to be used. Then click OK.

5. Complete the setup

Click OK on the Page Setup tab.

When you execute print, the data is printed with the specified paper size.

Important

- If you use a custom paper size to print, specify the size of paper correctly in the Custom Paper Size dialog box.
If an error message appears when you use the specified paper size, uncheck the Detect Paper Width check box on the Custom Settings dialog box of the Maintenance tab.

Related Topic

[➡ Changing the Printer Operation Mode](#)

[Page top ↑](#)

Advanced Guide

Advanced Guide > Printing from a Computer > Printing with Other Application Software > Changing the Print Quality and Correcting Image Data

Changing the Print Quality and Correcting Image Data

- [Selecting a Combination of the Print Quality Level and a Halftoning Method](#)
- [Printing a Color Document in Monochrome](#)
- [Adjusting Tone](#)
- [Specifying Color Correction](#)
- [Optimal Photo Printing of Image Data](#)
- [Adjusting Colors with the Printer Driver](#)
- [Printing with ICC Profiles](#)
- [Adjusting Color Balance](#)
- [Adjusting Brightness](#)
- [Adjusting Intensity](#)
- [Adjusting Contrast](#)
- [Simulating an Illustration](#)
- [Representing Image Data with a Single Color](#)
- [Presenting Image Data with Vivid Colors](#)
- [Smoothing Jagged Outlines](#)
- [Changing Color Properties to Improve Coloration](#)
- [Reducing Photo Noise](#)

[Page top](#) ↕

Advanced Guide

Advanced Guide > Printing from a Computer > Printing with Other Application Software > Changing the Print Quality and Correcting Image Data > Selecting a Combination of the Print Quality Level and a Halftoning Method

Selecting a Combination of the Print Quality Level and a Halftoning Method

You can set the print quality level and the halftoning method.



The procedure for setting the print quality level and the halftoning method is as follows:

1. Open the printer driver setup window
2. Select the print quality

Select Custom for Print Quality on the Main tab, and click Set...

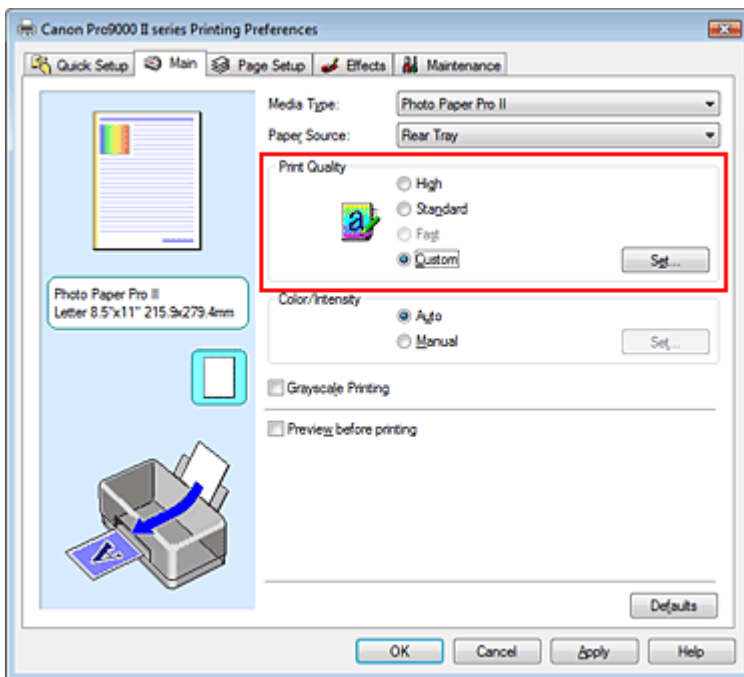

The Custom dialog box opens.

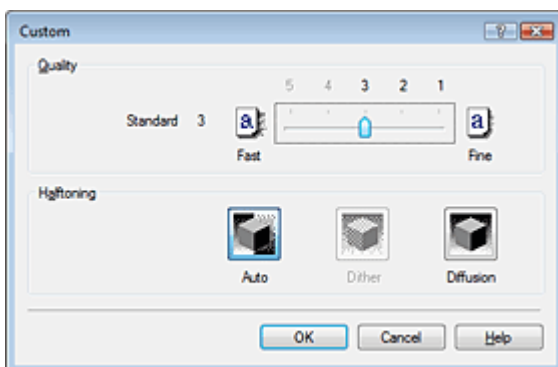

3. Setting the print quality and halftone expression method

Move the Quality slider to select the quality level.
Select Halftoning and click OK.

 **Note**

- Halftones refer to color shades between the darkest color and the brightest color. The printer replaces the color shades with a collection of small dots to express the halftones. Dither arranges the dots according to fixed rules to express the halftones. Diffusion places the dots randomly to express the halftones. When you select Auto, the data is printed with the optimal halftoning method for the selected print quality.

4. Complete the setup

Click OK on the Main tab.

When you execute print, the data is printed with the specified quality level and halftoning method.

 **Important**

- Certain print quality levels and halftoning methods cannot be selected depending on the settings of Media Type.

 **Note**

- When the part of the object is not printed, selecting Diffusion for Halftoning may solve the problem.

Related Topics

- ➔ [Specifying Color Correction](#)
- ➔ [Adjusting Color Balance](#)
- ➔ [Adjusting Brightness](#)
- ➔ [Adjusting Intensity](#)
- ➔ [Adjusting Contrast](#)

Advanced Guide

Advanced Guide > Printing from a Computer > Printing with Other Application Software > Changing the Print Quality and Correcting Image Data > Printing a Color Document in Monochrome

Printing a Color Document in Monochrome

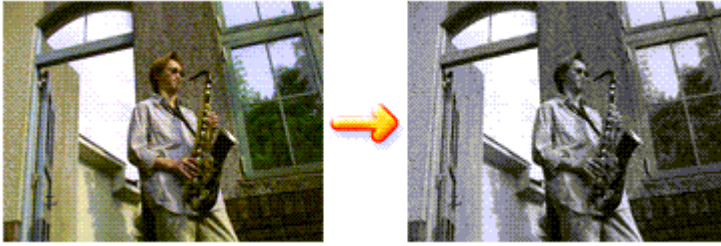

The procedure for printing a color document in monochrome is as follows:

You can also set a grayscale printing in Additional Features on the Quick Setup tab.

1. Open the **printer driver setup window**
2. Set grayscale printing

Check the Grayscale Printing check box on the Main tab.

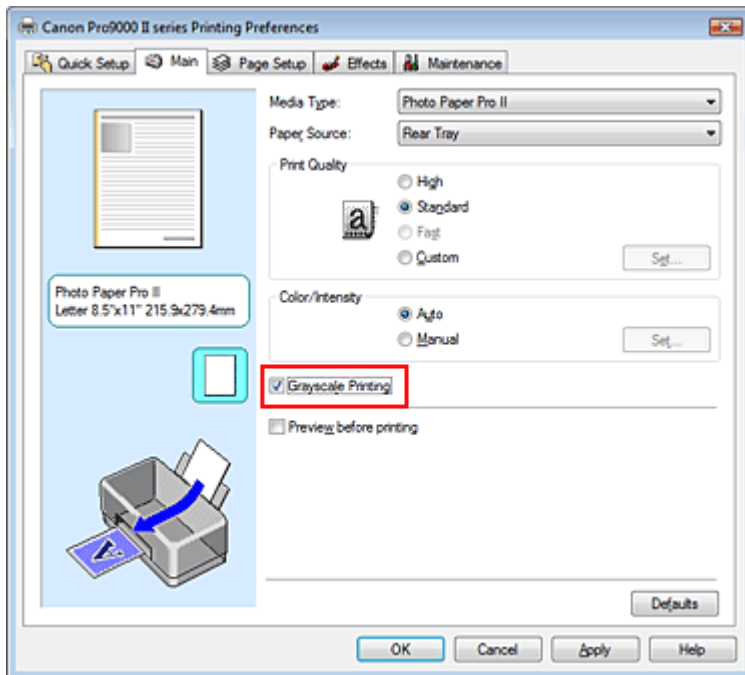

3. Complete the setup

Click OK.

When you execute print, the document is converted to grayscale data. It allows you to print the color document in monochrome.

Important

- When the Grayscale Printing check box is checked, the printer driver processes image data as sRGB data. In this case, actual colors printed may differ from those in the original image data. When using the grayscale printing function to print Adobe RGB data, convert the data to sRGB data using an application software.

Note

- During Grayscale Printing, color inks may be used as well as black ink.

Related Topic

➡ Adjusting Tone

Page top ↑

Advanced Guide

Advanced Guide > Printing from a Computer > Printing with Other Application Software > Changing the Print Quality and Correcting Image Data > Adjusting Tone

Adjusting Tone

When printing black and white photos, you can produce the cooling effects of cool colors and the warming effects of warm colors.



Tone is set to Cool

Tone is set to standard

Tone is set to Warm

The procedure for adjusting tone is as follows:

1. Open the **printer driver setup window**

2. Select the media type

Select the type of paper loaded in the printer from the Media Type list on the Main tab.

3. Set grayscale printing

Check the Grayscale Printing check box.

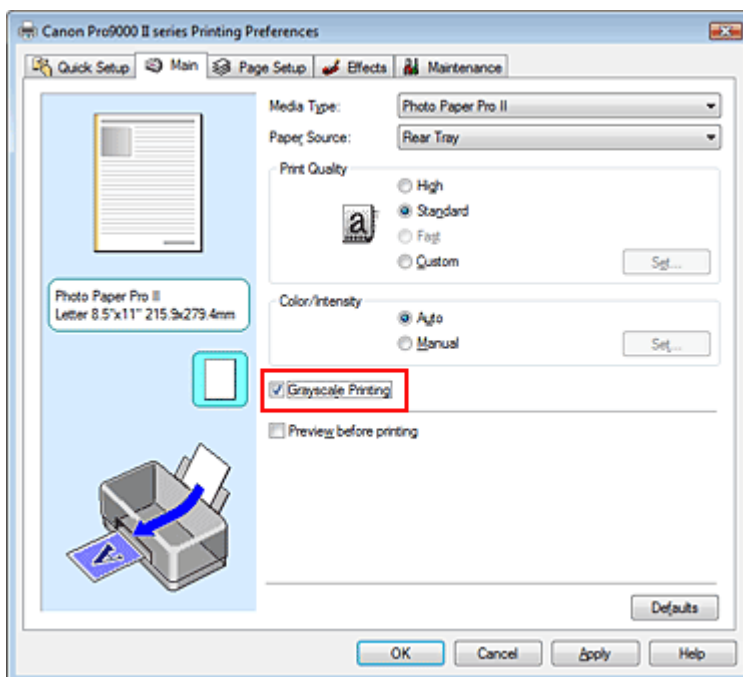

4. Select the manual color adjustment

Select Manual for Color/Intensity, and click Set....

The Manual Color Adjustment dialog box opens.

5. Adjusting monochrome tones

Moving the Tone slider to the right brings out the warm colors (Warm), and moving it to the left brings out the cool colors (Cool).

You can also directly enter a value linked to the slider. Enter a value in the range from -50 to 50.

After adjusting the tones, click OK.

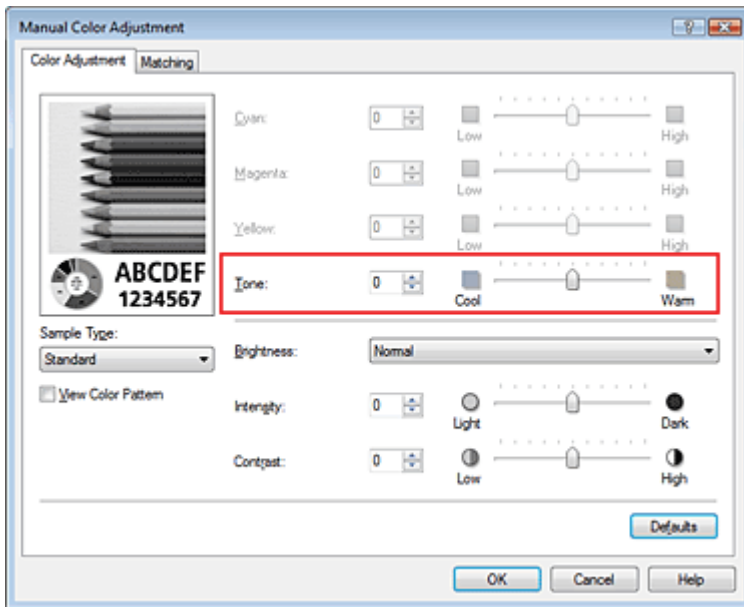

6. Complete the setup

Click OK on the Main tab.

The color document is converted to grayscale data with adjusted tones. It allows you to print the color document in monochrome.

Note

- If white streaks appear at the top and bottom of the paper when you print black and white photos, use your application software to set top and bottom margins of at least 45 mm (1.77 inch) in the print direction, and then print the photo.

Related Topics

- ➔ [Printing a Color Document in Monochrome](#)
- ➔ [Adjusting Brightness](#)
- ➔ [Adjusting Intensity](#)
- ➔ [Adjusting Contrast](#)

Advanced Guide

Advanced Guide > Printing from a Computer > Printing with Other Application Software > Changing the Print Quality and Correcting Image Data > Specifying Color Correction

Specifying Color Correction

You can specify the color correction method suited to the type of document to be printed. Normally, the printer driver adjusts the colors by using Canon Digital Photo Color so that data is printed with color tints that most people prefer. This method is suitable for printing sRGB data.

If you want to print by using the color space of sRGB or Adobe RGB data effectively, select ICM. If you want to use an application software to specify a printing ICC profile, select None.

The procedure for specifying color correction is as follows:

You can also set color correction on the Quick Setup tab by choosing Color/Intensity Manual Adjustment under Additional Features.

1. Open the **printer driver setup window**
2. Select the manual color adjustment

On the Main tab, select Manual for Color/Intensity, and click Set....

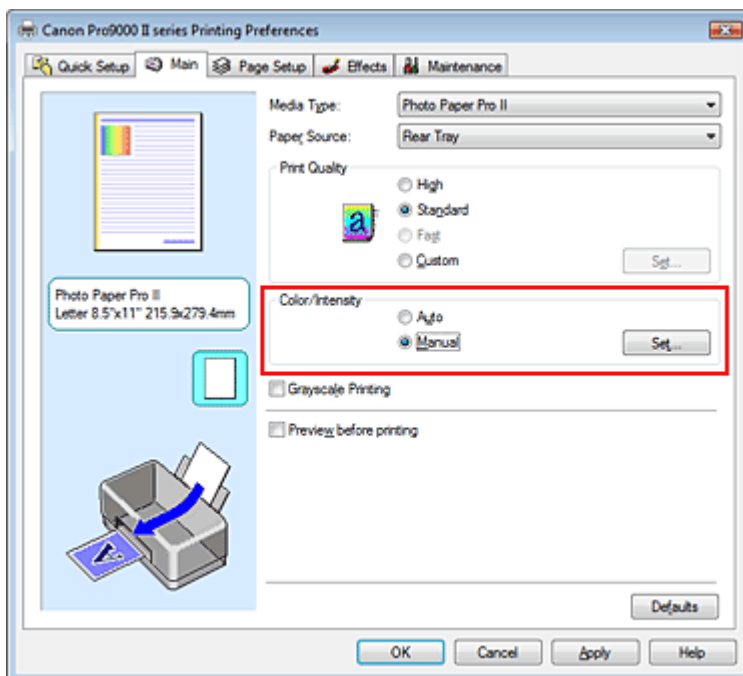

The Manual Color Adjustment dialog box opens.

3. Select color correction

Click Matching tab, select Color Correction setting suited to your purpose from the following, and click OK.

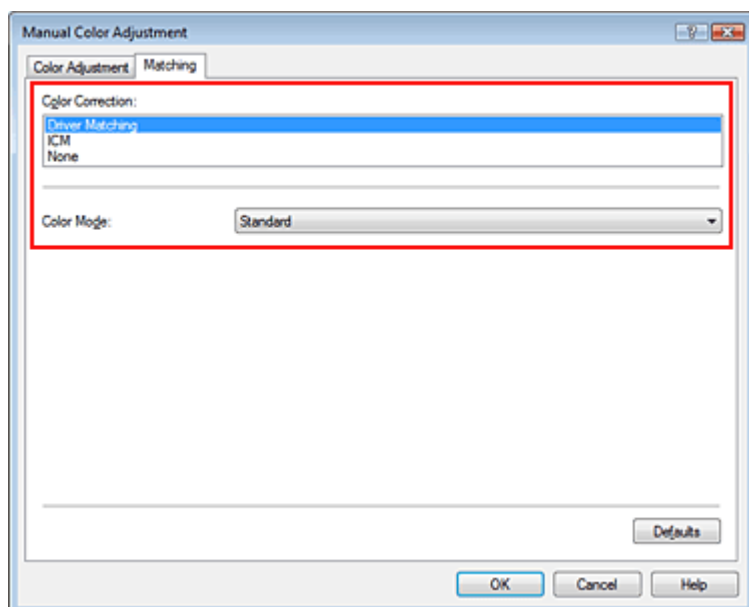

Driver Matching

By using Canon Digital Photo Color, you can print sRGB data with color tints that most people prefer. Driver Matching is the default setting for Color Correction.

ICM

You can print by using the color space of sRGB or Adobe RGB data effectively.

None

The printer driver does not perform color adjustment. Select this value if you are specifying an individually created printing ICC profile or a printing ICC profile for special Canon paper in an application software to print data.

4. Complete the setup

Click OK on the Main tab.

When you execute print, the data is printed with the specified color adjustment method.

Important

- If ICM is disabled in the application software, ICM is unavailable for Color Correction and the printer may not be able to print the image data properly.
- When the Grayscale Printing check box on the Main tab is checked, Color Correction appears grayed out and is unavailable.

Related Topics

- ➔ [Optimal Photo Printing of Image Data](#)
- ➔ [Adjusting Colors with the Printer Driver](#)
- ➔ [Printing with ICC Profiles](#)



Advanced Guide

[Advanced Guide](#) > [Printing from a Computer](#) > [Printing with Other Application Software](#) > [Changing the Print Quality and Correcting Image Data](#) > [Specifying Color Correction](#) > [Optimal Photo Printing of Image Data](#)

Optimal Photo Printing of Image Data

When people print images taken with digital cameras, they sometimes feel that the printed color tones differ from those of actual image or those displayed on the monitor.

To get the print results as close as possible to the desired color tones, you must select a printing method that is best suited to the application software used or to your purpose.

Color Management

Devices such as digital cameras, scanners, monitors, and printers handle color differently. Color management (color matching) is a method that manages device-dependent "colors" as a common color space. For Windows, a color management system called "ICM" is built into the operating system. Adobe RGB and sRGB are popularly used as common color spaces. Adobe RGB has a wider color space than sRGB.

ICC profiles convert device-dependent "colors" into a common color space.

By using an ICC profile and carrying out color management, you can draw out the color space of the image data within the color reproduction area that the printer can express.



Note

- Normally, image files are saved in JPEG format. Some digital cameras allow you to save images in a format called RAW. RAW data refers to an image saving format that requires a computer to develop the image. You can embed an input ICC profile tag into a RAW file by using special application software.

Selecting a Printing Method Suited to the Image Data

The recommended printing method depends on the color space (Adobe RGB or sRGB) of the image data or the application software to be used. There are two typical printing methods. Check the color space (Adobe RGB or sRGB) of the image data and the application software to be used, and then select the printing method suited to your purpose.

Adjusting Colors with the Printer Driver

Describes the procedure for printing sRGB data by using the color correction function of the printer driver.

● To print using Canon Digital Photo Color

The printer prints data with color tints that most people prefer, reproducing colors of the original image data and producing three-dimensional effects and high, sharp contrasts.

● To print by directly applying editing and touch-up results of an application software

When printing the data, the printer brings out subtle color difference between dark and light areas, while leaving the darkest and lightest areas intact.

When printing the data, the printer applies fine adjustment results, such as brightness adjustments made with an application software.

Printing with ICC Profiles

Describes the procedure for printing by using the color space of Adobe RGB or sRGB effectively.

You can print with a common color space by setting up the application software and the printer driver so that the color management matches the input ICC profile of the image data.

The method for setting up the printer driver differs depending on the application software to be used.



Advanced Guide

Advanced Guide > Printing from a Computer > Printing with Other Application Software > Changing the Print Quality and Correcting Image Data > Specifying Color Correction > Adjusting Colors with the Printer Driver

Adjusting Colors with the Printer Driver

You can specify the color correction function of the printer driver to print sRGB data with color tints that most people prefer (through the use of Canon Digital Photo Color).
When printing from an application software that can identify ICC profiles and allows you to specify them, use a printing ICC profile in the application software, and select settings for color management.

The procedure for adjusting colors with the printer driver is as follows:

1. Open the **printer driver setup window**
2. Select the media type

Select the type of paper loaded in the printer from the Media Type list on the Main tab.

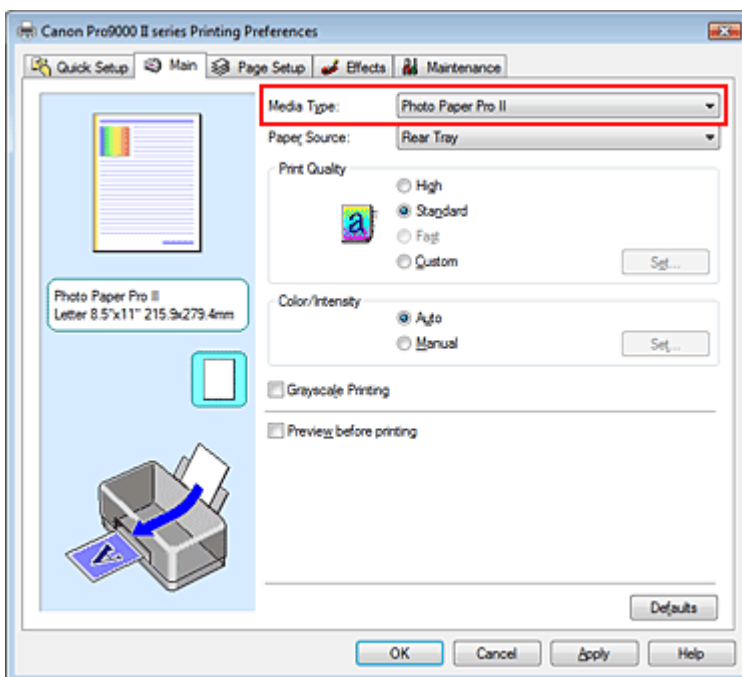

3. Select the print quality

Select High, Standard, or Fast for Print Quality.

Important

- Certain print quality levels cannot be selected depending on the settings of Media Type.

4. Select the manual color adjustment

Select Manual for Color/Intensity, and click Set....
The Manual Color Adjustment dialog box opens.

5. Select color correction

Click Matching tab, and select Driver Matching for Color Correction.

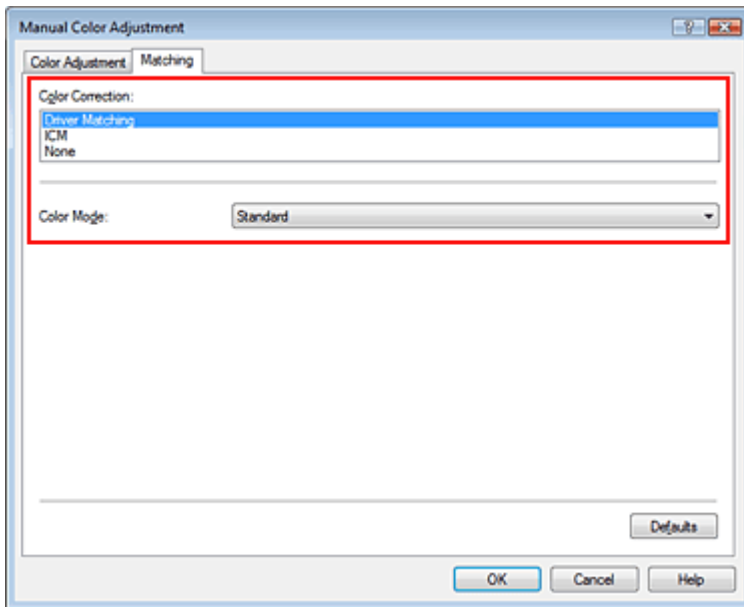

6. Select Color Mode

- **To print using Canon Digital Photo Color:**

Select Standard.

The printer prints data with color tints that most people prefer, reproducing colors of the original image data and producing three-dimensional effects and high, sharp contrasts.

- **To print data by directly applying the editing and touch-up results of the application software:**

Select Linear Tone.

When printing the data, the printer brings out subtle color difference between dark (black) and bright (white) areas, while leaving the darkest (blackest) and brightest (whitest) areas intact.

When printing the data, the printer applies fine adjustment results, such as brightness adjustments made with an application software.

7. Set the other items

If necessary, click Color Adjustment tab, and adjust the color balance of Cyan, Magenta, Yellow, and adjust Brightness, Intensity, and Contrast settings, and then click OK.

8. Complete the setup

Click OK on the Main tab.

When you execute print, the printer driver adjusts the colors when printing the data.

Related Topics

- ➔ [Selecting a Combination of the Print Quality Level and a Halftoning Method](#)
- ➔ [Specifying Color Correction](#)
- ➔ [Adjusting Color Balance](#)
- ➔ [Adjusting Brightness](#)
- ➔ [Adjusting Intensity](#)
- ➔ [Adjusting Contrast](#)



Advanced Guide

Advanced Guide > Printing from a Computer > Printing with Other Application Software > Changing the Print Quality and Correcting Image Data > Specifying Color Correction > Printing with ICC Profiles

Printing with ICC Profiles

If the image data has a specified input ICC profile, you can effectively use the color space (Adobe RGB or sRGB) of the data when printing.

The printer driver setting procedure varies depending on the application software used to print.

Specify an ICC Profile from the Application Software and Print the Data

When you print the editing and touch-up results of Adobe Photoshop, Canon Digital Photo Professional, or any application software that allows you to specify input and printing ICC profiles, you print by effectively using the color space of the input ICC profile specified in the image data.

To use this printing method, use your application software to select color management items and specify an input ICC profile and a printing ICC profile in the image data.

Even if you print using a printing ICC profile that you created yourself or one for special Canon paper from your application software, be sure to select color management items from your application software. For instructions, refer to the manual of the application software you are using.

1. Open the printer driver setup window

2. Select the media type

Select the type of paper loaded in the printer from the Media Type list on the Main tab.

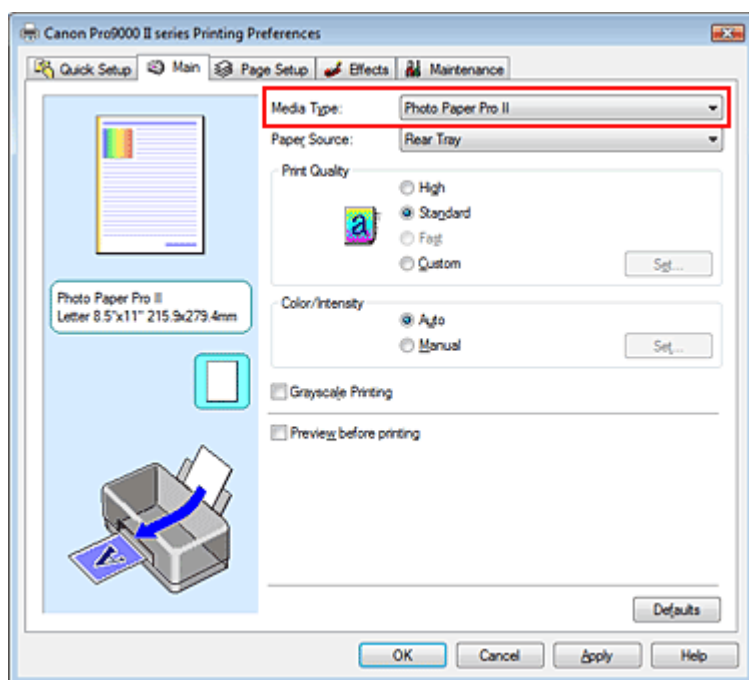

3. Select the print quality

Select High, Standard, or Fast for Print Quality.

Important

- Certain print quality levels cannot be selected depending on the settings of Media Type.

4. Select the manual color adjustment

Select Manual for Color/Intensity, and click Set....
The Manual Color Adjustment dialog box opens.

5. Select color correction

Click Matching tab, and select None for Color Correction.

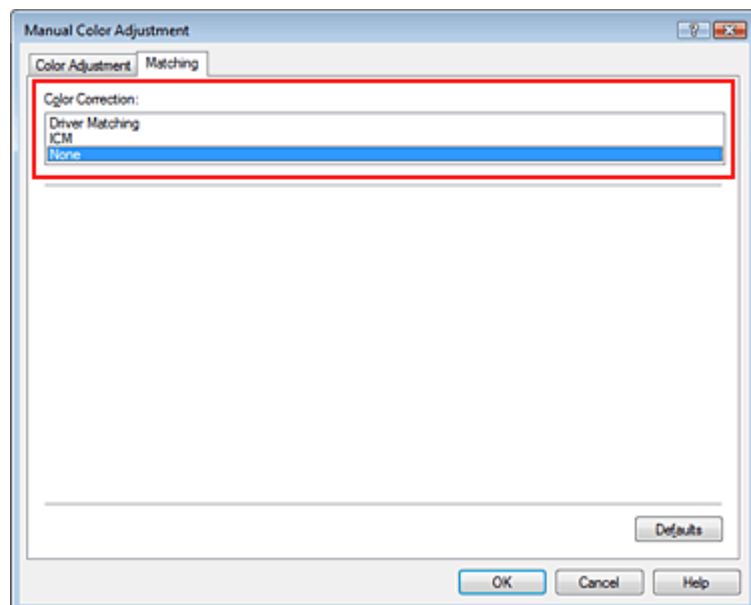

6. Set the other items

If necessary, click Color Adjustment tab, and adjust the color balance of Cyan, Magenta, Yellow, and adjust Brightness, Intensity, and Contrast settings, and then click OK.

7. Complete the setup

Click OK on the Main tab.

When you execute print, the printer uses the color space of the image data.

Specify an ICC Profile with the Printer Driver, and then Print

When you print from an application software that cannot identify input ICC profiles or does allow you to specify one, the printer prints using the color space of the input ICC profile found in the data. When printing Adobe RGB data, you can print the data with the Adobe RGB color space even if the application software does not support Adobe RGB.

1. Open the printer driver setup window

2. Select the media type

Select the type of paper loaded in the printer from the Media Type list on the Main tab.

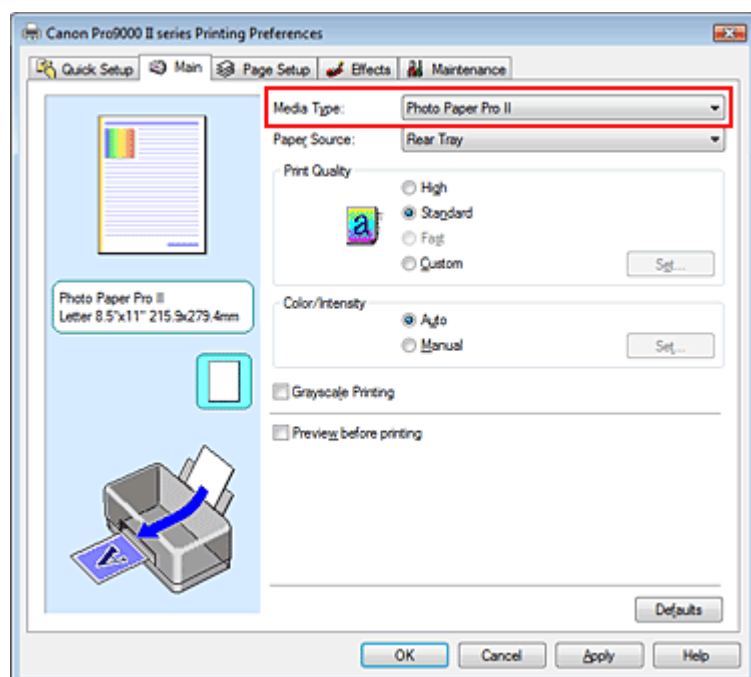

3. Select the print quality

Select High, Standard, or Fast for Print Quality.

4. Select the manual color adjustment

Select Manual for Color/Intensity, and click Set...
Manual Color Adjustment dialog box opens.

5. Select color correction

Click Matching tab, and select ICM for Color Correction.

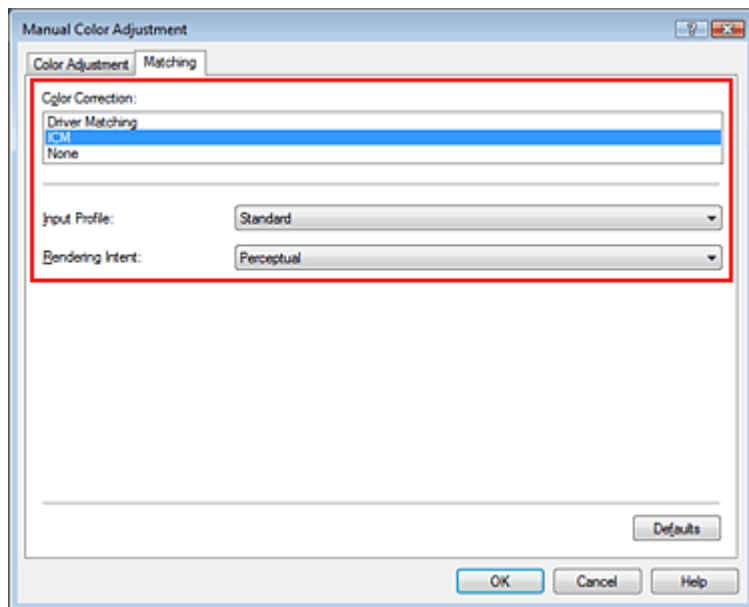
**6. Select the input profile**

Select an Input Profile that matches the color space of the image data.

- **For sRGB data or data without an input ICC profile:**

Select Standard.

- **For Adobe RGB data:**

Select Adobe RGB (1998).

Important

- If the application software specifies an input profile, the input profile setting of the printer driver becomes invalid.
- If no input ICC profiles are installed on your computer, Adobe RGB (1998) is not displayed. You can install ICC profiles from the Setup CD-ROM that accompanies the printer.

7. Select the rendering intent

Select the coloring adjustment method in Rendering Intent.

- **Saturation**

This method reproduces images even more vividly than the Perceptual method.

- **Perceptual**

This method reproduces images by focusing on colors that most people find desirable. Select this method to print photos.

- **Relative Colorimetric**

When image data is converted to the color space of the printer, this method converts the image data so the color reproduction approximates the shared color regions. Select this method to print image data with colors that are close to the original colors.

- **Abosolute Colorimetric**

When Relative Colorimetric is selected, white spots are reproduced as white spots of the paper (background color). However, when Abosolute Colorimetric is selected, how the white spots are

reproduced depends on the image data.

Important

- When Windows XP SP2 or Windows XP SP3 is used, this function is disabled.

8. Set the other items

If necessary, click Color Adjustment tab, and adjust the color balance of Cyan, Magenta, Yellow, and adjust Brightness, Intensity, and Contrast settings, and then click OK.

9. Complete the setup

Click OK on the Main tab.

When you execute print, the data is printed with the color space of the selected image data.

Related Topics

- ➔ [Selecting a Combination of the Print Quality Level and a Halftoning Method](#)
- ➔ [Specifying Color Correction](#)
- ➔ [Adjusting Color Balance](#)
- ➔ [Adjusting Brightness](#)
- ➔ [Adjusting Intensity](#)
- ➔ [Adjusting Contrast](#)



[Page top](#) ↑

Advanced Guide

Advanced Guide > Printing from a Computer > Printing with Other Application Software > Changing the Print Quality and Correcting Image Data > Adjusting Color Balance

Adjusting Color Balance

You can adjust the color tints during printing.

Since this function adjusts color balance of the output by changing the ink ratios of each color, it changes the total color balance of the document. Use the application software if you want to change the color balance significantly. Use the printer driver only if you want to adjust the color balance slightly.

The following sample shows the case when Color Balance is used to intensify cyan and to diminish yellow so that the overall colors are more uniform.



No adjustment

Adjusted in Color Balance

The procedure for adjusting color balance is as follows:

You can also set color balance on the Quick Setup tab by choosing Color/Intensity Manual Adjustment under Additional Features.

1. Open the **printer driver setup window**
2. Select the manual color adjustment

On the Main tab, select Manual for Color/Intensity, and click Set....

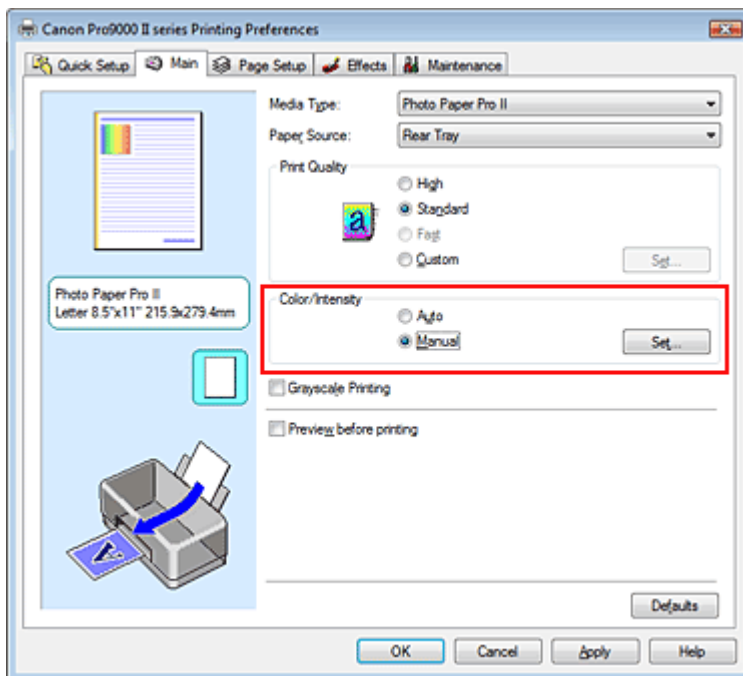

The Manual Color Adjustment dialog box opens.

3. Adjust color balance

There are individual sliders for Cyan, Magenta, and Yellow. Each color becomes stronger when the corresponding slider is moved to the right, and becomes weaker when the corresponding slider is moved to the left. For example, if cyan becomes weaker, the color red becomes stronger.

You can also directly enter a value linked to the slider. Enter a value in the range from -50 to 50.

After adjusting each color, click OK.

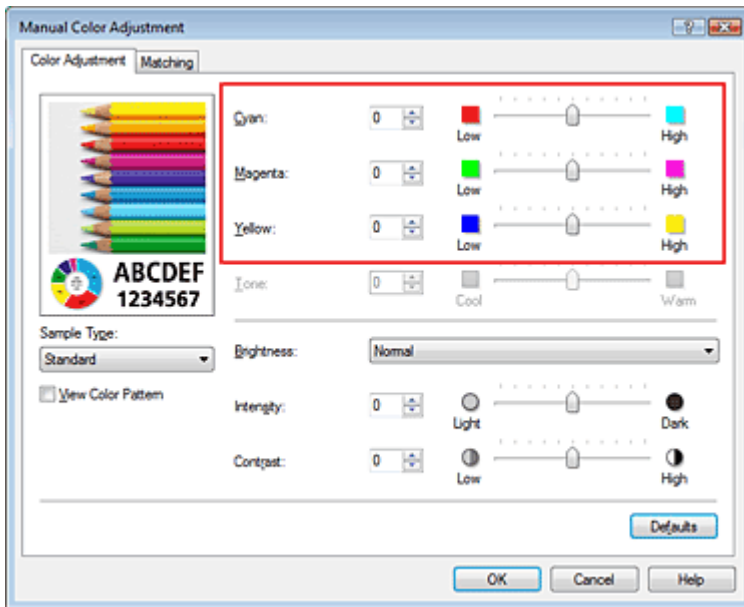

Important

- Adjust the slider gradually.

4. Complete the setup

Click OK on the Main tab.

When you execute print, the document is printed with the adjusted color balance.

Important

- When the Grayscale Printing check box on the Main tab is checked, Cyan, Magenta, and Yellow appear grayed out and are unavailable.

Related Topics

- ➔ [Selecting a Combination of the Print Quality Level and a Halftoning Method](#)
- ➔ [Specifying Color Correction](#)
- ➔ [Adjusting Brightness](#)
- ➔ [Adjusting Intensity](#)
- ➔ [Adjusting Contrast](#)

Advanced Guide

Advanced Guide > Printing from a Computer > Printing with Other Application Software > Changing the Print Quality and Correcting Image Data > Adjusting Brightness

Adjusting Brightness

You can change the brightness of the overall image data during printing. This function does not change pure white or pure black but it changes the brightness of the intermediate colors.

The following sample shows the print result when the Brightness specification is changed.



Light is selected

Normal is selected

Dark is selected

The procedure for adjusting brightness is as follows:

You can also set brightness on the Quick Setup tab by choosing Color/Intensity Manual Adjustment under Additional Features.

1. Open the printer driver setup window

2. Select the manual color adjustment

On the Main tab, select Manual for Color/Intensity, and click Set....

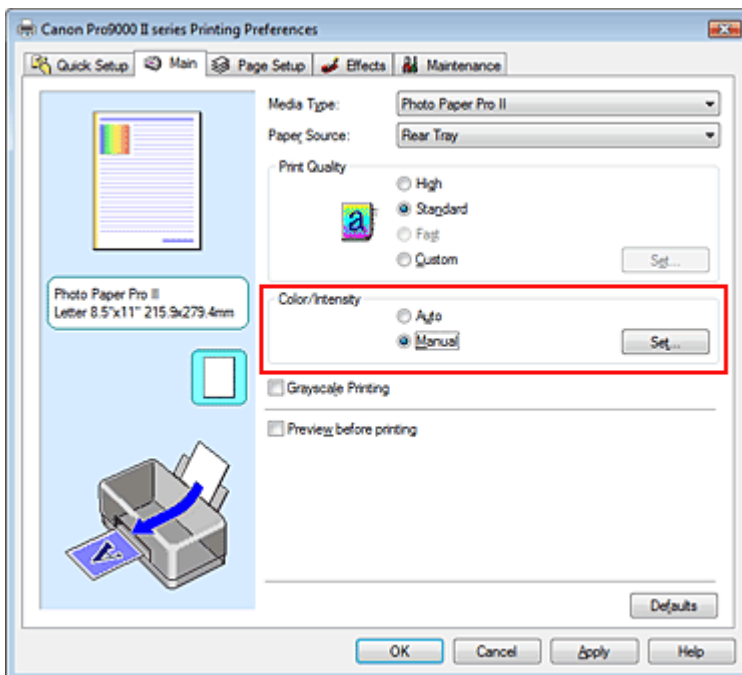

The Manual Color Adjustment dialog box opens.

3. Specify the brightness

Select Light, Normal, or Dark for Brightness, and click OK.

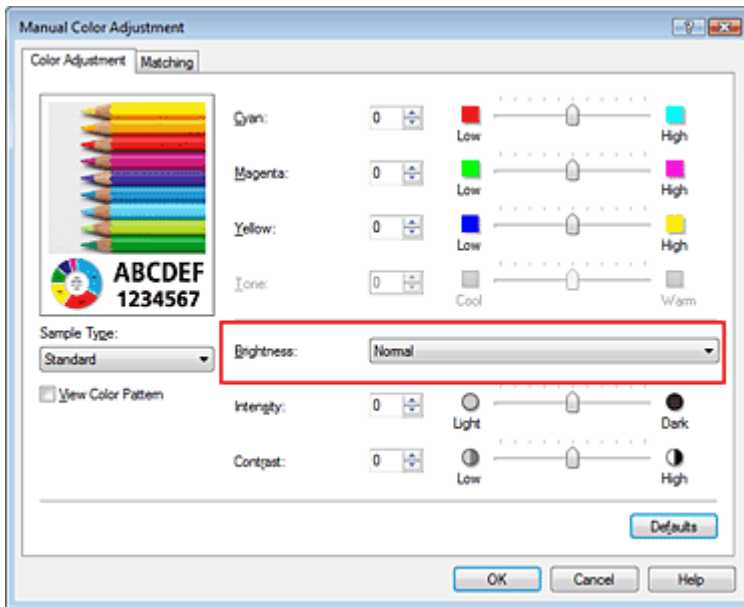

4. Complete the setup

Click OK on the Main tab.

When you execute print, the data is printed at the specified brightness.

Related Topics

- Selecting a Combination of the Print Quality Level and a Halftoning Method
- Specifying Color Correction
- Adjusting Color Balance
- Adjusting Intensity
- Adjusting Contrast

Advanced Guide

Advanced Guide > Printing from a Computer > Printing with Other Application Software > Changing the Print Quality and Correcting Image Data > Adjusting Intensity

Adjusting Intensity

You can dilute (brighten) or intensify (darken) the colors of the overall image data during printing. If you want to sharpen the print results, you should intensify the colors. The following sample shows the case when the intensity is increased so that all colors become more intense when the image data is printed.



No adjustment

Higher Intensity

The procedure for adjusting intensity is as follows:

You can also set intensity on the Quick Setup tab by choosing Color/Intensity Manual Adjustment under Additional Features.

1. Open the **printer driver setup window**
2. Select the manual color adjustment

Select Manual for Color/Intensity on the Main tab, and click Set....

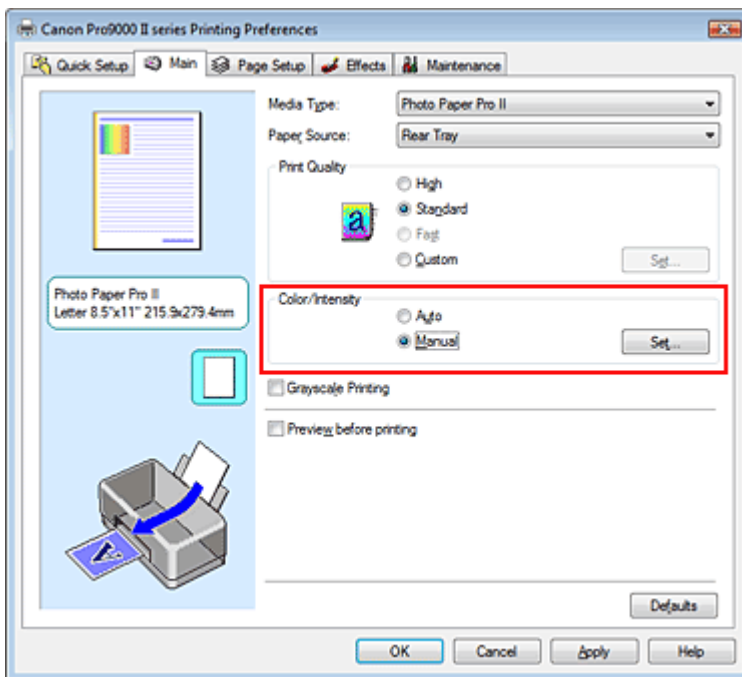

The Manual Color Adjustment dialog box opens.

3. Adjust intensity

Moving the Intensity slider to the right intensifies (darkens) the colors. Moving the slider to the left dilutes (brightens) the colors.

You can also directly enter a value linked to the slider. Enter a value in the range from -50 to 50.

After adjusting each color, click OK.

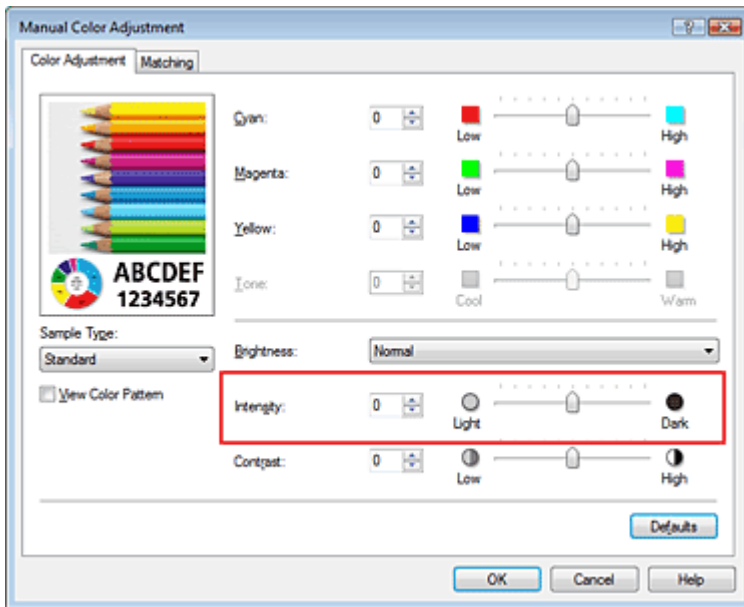

Important

- Adjust the slider gradually.

4. Complete the setup

Click OK on the Main tab.

When you execute print, the image data is printed with the adjusted intensity.

Related Topics

- ➔ Selecting a Combination of the Print Quality Level and a Halftoning Method
- ➔ Specifying Color Correction
- ➔ Adjusting Color Balance
- ➔ Adjusting Brightness
- ➔ Adjusting Contrast

Advanced Guide

Advanced Guide > Printing from a Computer > Printing with Other Application Software > Changing the Print Quality and Correcting Image Data > Adjusting Contrast

Adjusting Contrast

You can adjust the image contrast during printing.

To make the differences between the light and dark portions of images greater and more distinct, increase the contrast. On the other hand, to make the differences between the light and dark portions of images smaller and less distinct, reduce the contrast.



No adjustment

Adjust the contrast

The procedure for adjusting contrast is as follows:

You can also set contrast on the Quick Setup tab by choosing Color/Intensity Manual Adjustment under Additional Features.

1. Open the [printer driver setup window](#)
2. Select the manual color adjustment

On the Main tab, select Manual for Color/Intensity, and click Set....

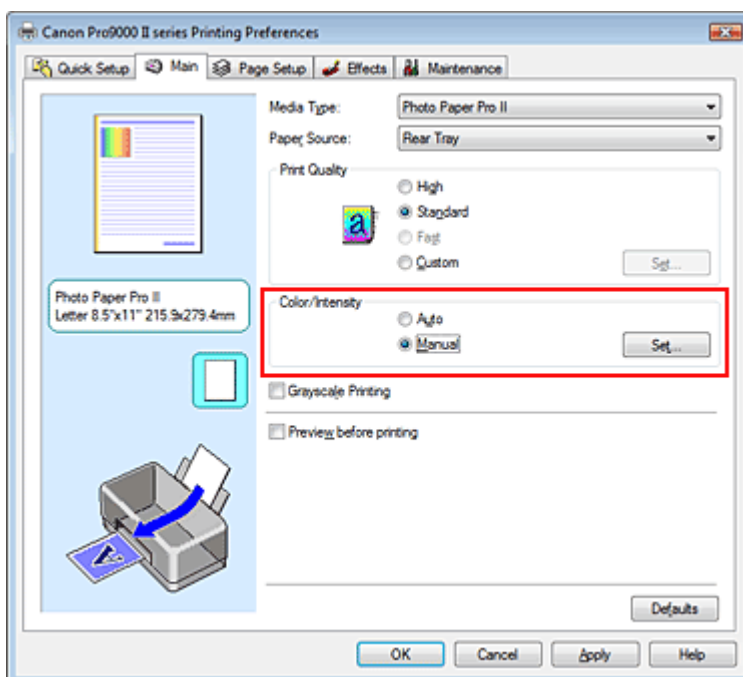

The Manual Color Adjustment dialog box opens.

3. Adjust the contrast

Moving the Contrast slider to the right increases the contrast, and moving it to the left decreases the contrast.

You can also directly enter a value linked to the slider. Enter a value in the range from -50 to 50.

After adjusting each color, click OK.

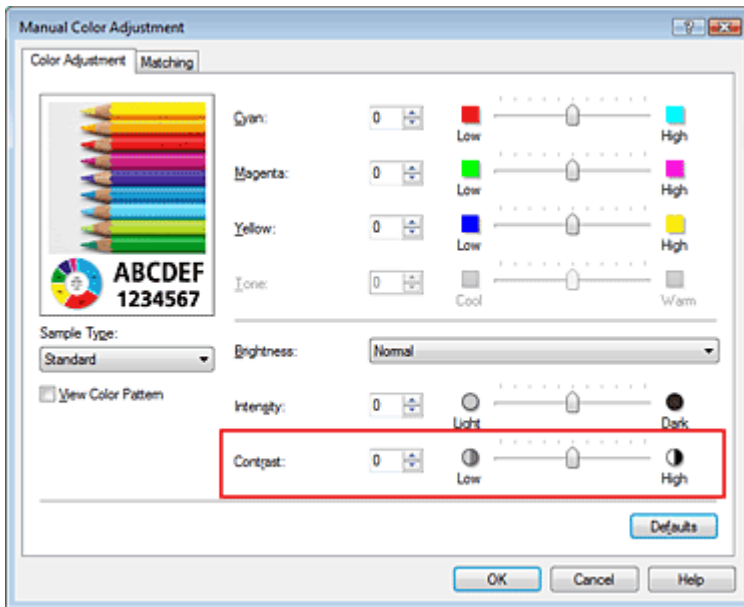

Important

- Adjust the slider gradually.

4. Complete the setup

Click OK on the Main tab.

When you execute print, the image is printed with the adjusted contrast.

Related Topics

- ➔ [Selecting a Combination of the Print Quality Level and a Halftoning Method](#)
- ➔ [Specifying Color Correction](#)
- ➔ [Adjusting Color Balance](#)
- ➔ [Adjusting Brightness](#)
- ➔ [Adjusting Intensity](#)

Advanced Guide

Advanced Guide > Printing from a Computer > Printing with Other Application Software > Changing the Print Quality and Correcting Image Data > Simulating an Illustration

Simulating an Illustration

With the Simulate Illustration function, you can print full-color or 256-color image data so that it looks like a hand-drawn illustration. You can add different effects to the original profile and colors.

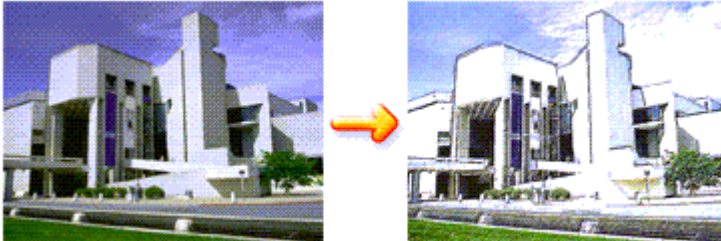

The procedure for performing Simulate Illustration is as follows:

1. Open the **printer driver setup window**
2. Set the Simulate Illustration

Check the Simulate Illustration check box on the Effects tab, and adjust the Contrast as necessary. Moving the slider to the right lightens the image data and moving the slider to the left darkens the image data.

The current settings are displayed in the Settings Preview on the left side of the printer driver.

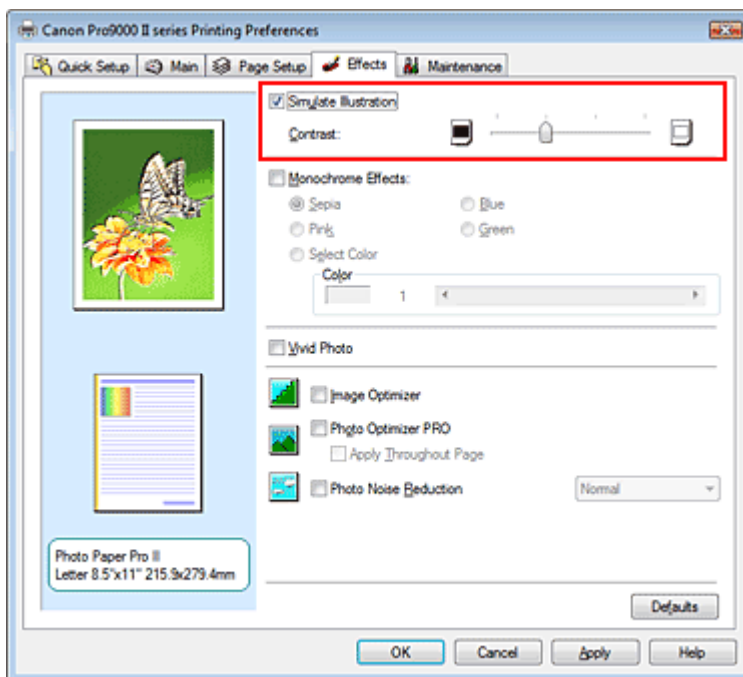

3. Complete the setup

Click OK.

When you execute print, the image will be printed so that it looks hand-drawn.

Advanced Guide

Advanced Guide > Printing from a Computer > Printing with Other Application Software > Changing the Print Quality and Correcting Image Data > Representing Image Data with a Single Color

Representing Image Data with a Single Color

With the Monochrome Effects function, you can benefit from coloring effects such as changing a photograph to a sepia tone image.

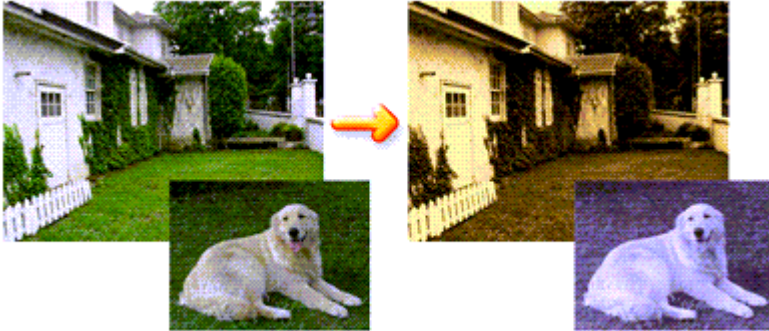

The procedure for performing Monochrome Effects is as follows:

1. Open the **printer driver setup window**
2. Set Monochrome Effects

Check the Monochrome Effects check box on the Effects tab and select your desired color.

If you use Select Color, move the Color slider to specify the color you want.

The current settings are displayed in the Settings Preview on the left side of the printer driver.

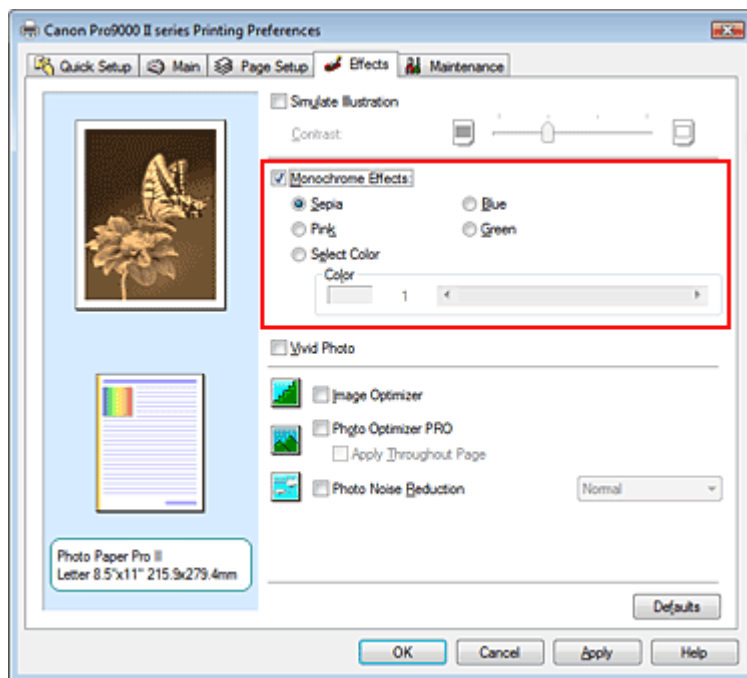

3. Complete the setup

Click OK.

When you execute print, the image will be printed with a single color.

Important

- When the Grayscale Printing check box on the Main tab is checked, Monochrome Effects appears grayed out and is unavailable.

Advanced Guide

Advanced Guide > Printing from a Computer > Printing with Other Application Software > Changing the Print Quality and Correcting Image Data > Presenting Image Data with Vivid Colors

Presenting Image Data with Vivid Colors

The Vivid Photo function allows you to print image data with vivid colors. The notable feature of Vivid Photo is that it emphasizes the colors in background sceneries while maintaining the human skin color natural. By using this function, you can make vivid hues appear even more vivid.

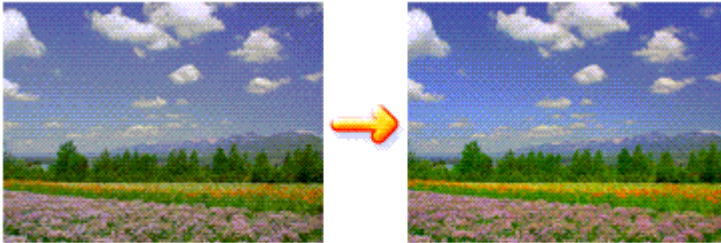

The procedure for performing Vivid Photo is as follows:
You can also set a vivid photos in Additional Features on the Quick Setup tab.

1. Open the **printer driver setup window**
2. Set Vivid Photo

Check the Vivid Photo check box on the Effects tab.

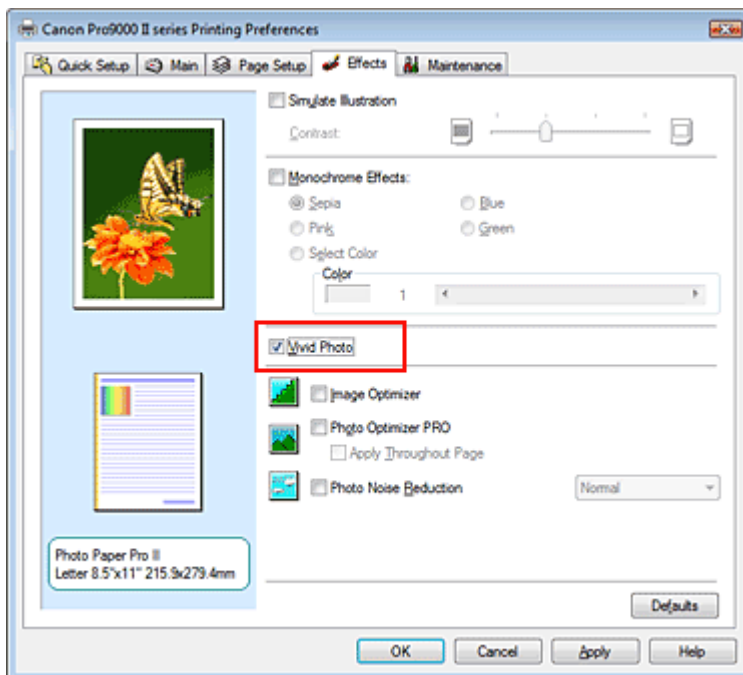

3. Complete the setup

Click OK.
When you execute print, the image will be printed with vivid colors.

Advanced Guide

Advanced Guide > Printing from a Computer > Printing with Other Application Software > Changing the Print Quality and Correcting Image Data > Smoothing Jagged Outlines

Smoothing Jagged Outlines

The Image Optimizer function allows you to smooth jagged outlines in photos and graphics that have been enlarged with your application. This feature is especially useful when printing low-resolution images from Web pages.

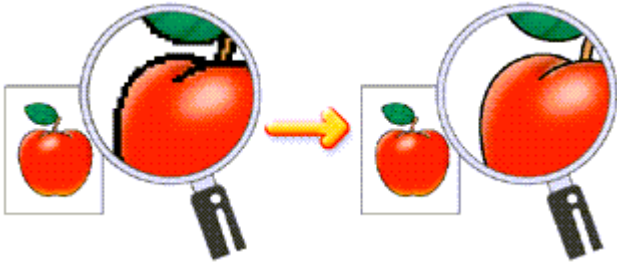

The procedure for performing Image Optimizer is as follows:

1. Open the [printer driver setup window](#)
2. Perform Image Optimizer

Check the Image Optimizer check box on the Effects tab.

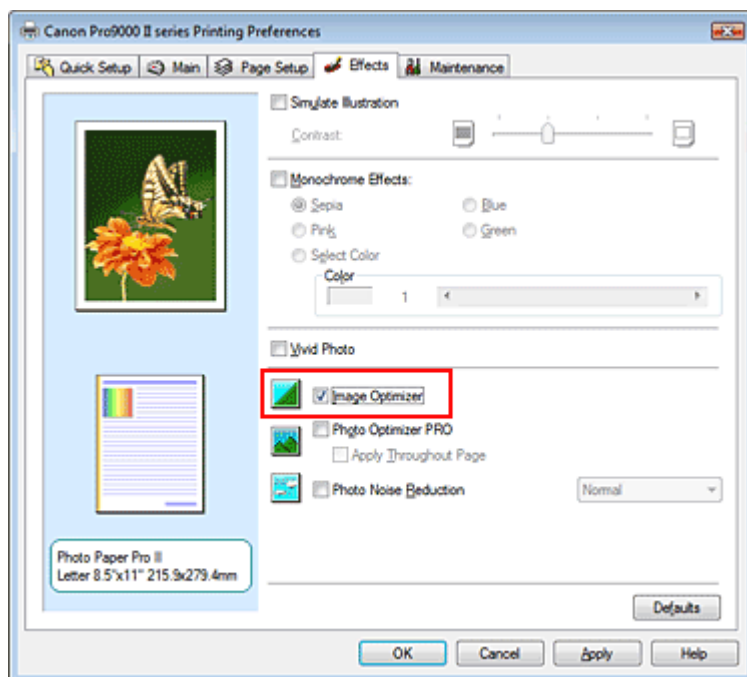

3. Complete the setup

Click OK.

The photos and graphics will be printed with jagged outlines smoothed.

Note

- Depending on application software or resolution of image data, the Image Optimizer may have no discernible effects.
- It may take longer to complete printing if the Image Optimizer is used.

Advanced Guide

Advanced Guide > Printing from a Computer > Printing with Other Application Software > Changing the Print Quality and Correcting Image Data > Changing Color Properties to Improve Coloration

Changing Color Properties to Improve Coloration

The Photo Optimizer PRO function corrects colors of digital camera images or scanned images. It is specially designed to compensate for color shift, overexposure, and underexposure.

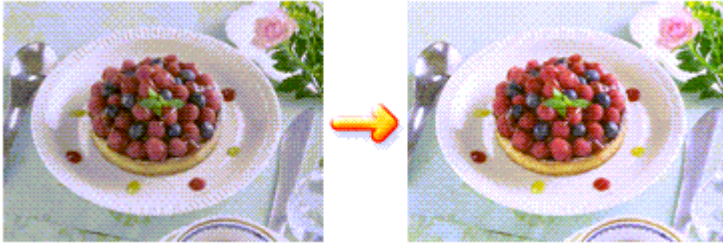

The procedure for performing Photo Optimizer PRO is as follows:

1. Open the printer driver setup window
2. Set the Auto Photo mode

Check the Photo Optimizer PRO check box on the Effects tab.

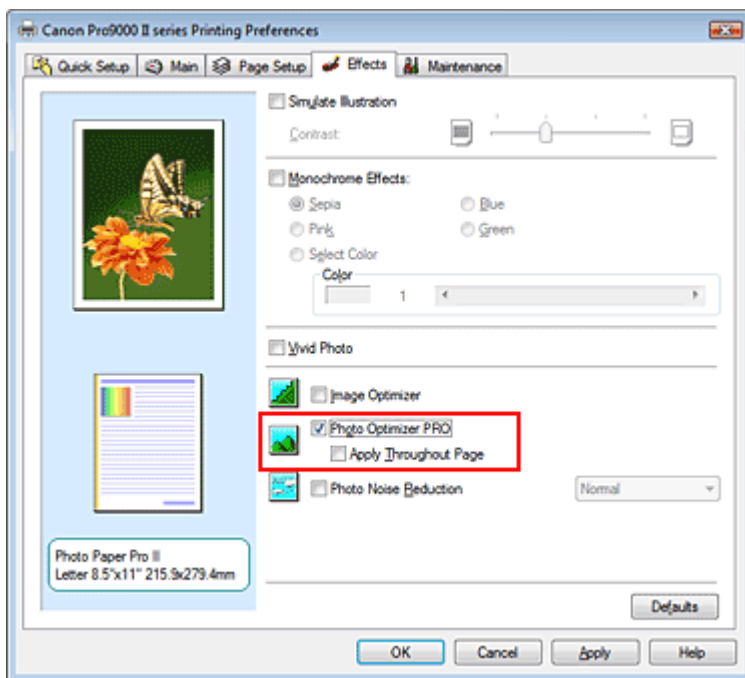

Normally there is no need to check the Apply Throughout Page check box. Images within each page are optimized on an image-by-image basis.

Note

- Check the Apply Throughout Page check box when printing image data that has been processed, such as being cropped or rotated. In this case the entire page will be treated as a single image to be optimized.

3. Complete the setup

Click OK.

When you execute print, the images will be printed with color compensation.

Important

- Photo Optimizer PRO does not function when:
 - Background is set in the Stamp/Background dialog box on the Page Setup tab.

- Define Stamp... is selected in the Stamp/Background dialog box on the Page Setup tab, and the bitmapped stamp is configured.

 **Note**

- Depending on images, the Photo Optimizer PRO may have no discernible effect.
-

[Page top](#) ↑

Advanced Guide

Advanced Guide > Printing from a Computer > Printing with Other Application Software > Changing the Print Quality and Correcting Image Data > Reducing Photo Noise

Reducing Photo Noise

With the Photo Noise Reduction function, you can reduce the digital camera noise and improve the image quality of the digital print.

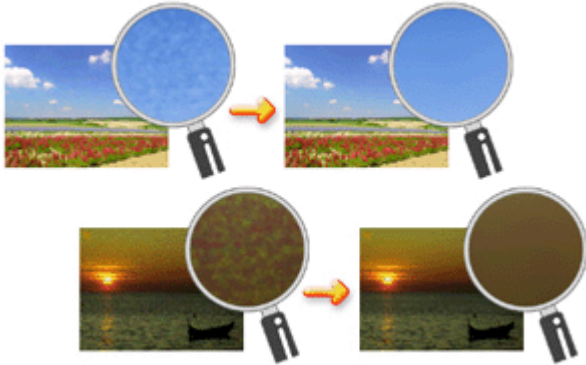

The procedure for performing Photo Noise Reduction is as follows:

1. Open the [printer driver setup window](#)
2. Set Photo Noise Reduction

Check the Photo Noise Reduction check box on the Effects tab and select Normal or Strong for the level.

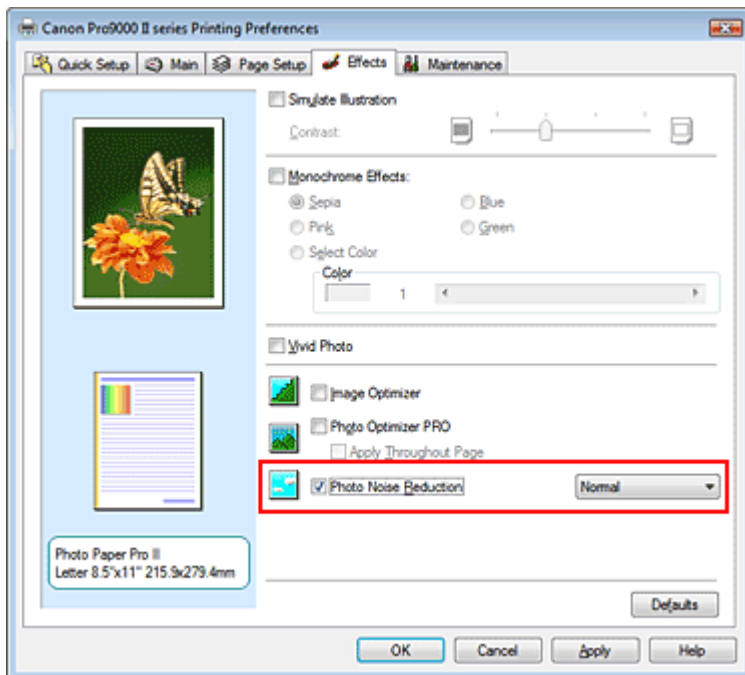

3. Complete the setup

Click OK.

When you execute print, the image will be printed with the digital camera noise being reduced.

Note

- It is recommended to select Normal for most cases. Select Strong if you have selected Normal and the noise still bothers you.
- Depending on application software or resolution of image data, effects of digital camera noise reduction may not be obvious.
- When this function is used for other than photos taken by digital cameras, image may be distorted.

Advanced Guide

[Advanced Guide](#) > [Printing from a Computer](#) > [Printing with Other Application Software](#) > [Overview of the Printer Driver](#)
> [Overview of the Printer Driver](#)

Overview of the Printer Driver

- ➔ [Canon IJ Printer Driver](#)
- ➔ [How to Open the Printer Driver Setup Window](#)
- ➔ [Maintenance Tab](#)
- ➔ [Canon IJ Status Monitor](#)
- ➔ [The Canon IJ Preview](#)

[Page top](#) ↕



Printer Driver Operations

MA-5158-V1.00



| Instructions for Use (Printer Driver) | How to Use This Manual | Printing This Manual |
| XPS Printer Driver |

Various Printing Methods

- Printing with Easy Setup
- Setting a Page Size and Orientation
- Setting the Number of Copies and Printing Order
- Setting the Stapling Margin
- Borderless Printing
- Fit-to-Page Printing
- Scaled Printing
- Page Layout Printing
- Poster Printing
- Booklet Printing
- Duplex Printing
- Stamp/Background Printing
- Printing an Envelope
- Front Feed Printing
- Displaying the Print Results before Printing
- Setting Paper Dimensions (Custom Size)

Changing the Print Quality and Correcting Image Data

- Selecting a Combination of the Print Quality Level and a Halftoning Method
- Printing a Color Document in Monochrome
- Adjusting Tone
- Specifying Color Correction
- Adjusting Color Balance
- Adjusting Brightness
- Adjusting Intensity
- Adjusting Contrast
- Simulating an Illustration
- Representing Image Data with a Single Color
- Presenting Image Data with Vivid Colors
- Smoothing Jagged Outlines
- Changing Color Properties to Improve Coloration
- Reducing Photo Noise

Changing Printer Settings from Your Computer

- Changing the Print Options
- Registering a Frequently Used Printing Profile
- Managing the Printer Power
- Reducing the Printer Noise
- Changing the Printer Operation Mode

Performing Maintenance from a Computer

- Cleaning the Print Heads
- Cleaning the Paper Feed Rollers
- Aligning the Print Head Position
- Checking the Print Head Nozzles
- Cleaning Inside the Printer

Overview of the Printer Driver

- Canon IJ Printer Driver
- How to Open the Printer Driver Setup Window
- Maintenance Tab
- Canon IJ Status Monitor
- The Canon IJ Preview

Updating the Printer Driver

- Obtaining the Latest Printer Driver
- Uninstalling the Printer Driver
- Before Installing the Printer Driver
- Installing the Printer Driver

Appendix

- Deleting the Undesired Print Job
- Sharing the Printer on a Network

Advanced Guide

[Advanced Guide](#) > [Printing from a Computer](#) > [Printing with Other Application Software](#) > [Overview of the Printer Driver](#)
> [Canon IJ Printer Driver](#)

Canon IJ Printer Driver

The Canon IJ printer driver is software that is installed on your computer for printing data on this printer.

The Canon IJ printer driver converts the print data created by your Windows application into data that your printer can understand and sends the converted data to the printer.

Because different models support different print data formats, you need a Canon IJ printer driver for the specific model you are using.

How to Use Help

You can display the Help describing the driver setting items through the Printing Preferences screen of the Canon IJ printer driver.

- **To view all descriptions of a tab...**

Click the Help button on each tab. A dialog box opens, displaying a description of each item on the tab.

You can also click the link found in the description of an item to display a description of the linked dialog box.

- **To see a description for each item...**

Right-click the item you want to learn about and then click Help.

Alternatively, if the  [Help] button is found at the right end of the title bar, click that button, and then click the item you want to learn about.

A description of the item is displayed.

Related Topic

[▶ How to Open the Printer Driver Setup Window](#)



Advanced Guide

Advanced Guide > Printing from a Computer > Printing with Other Application Software > Overview of the Printer Driver > Canon IJ Printer Driver > How to Open the Printer Driver Setup Window

How to Open the Printer Driver Setup Window

The printer driver setup window can be displayed through the application software in use or the Start menu of the Windows.

Note

- This guide mainly describes operations on the Windows Vista. Operations may differ depending on versions of the Windows.

Open the Printer Driver Setup Window through the Application Software

Follow the procedure below to configure print settings when printing.

1. Select the command you perform printing on the application software in use

In general, select Print on the File menu to open the Print dialog box.

2. Select your model name and click Preferences (or Properties)

The printer driver setup window appears.

Note

- Depending on application software you use, command names or menu names may vary and there may be more steps. For details, refer to the user's manual of your application software.

Open the Printer Driver Setup Window through the Start Menu

Follow the procedure below to perform maintenance operations such as print head cleaning, or to configure print settings that are common for all application software.

1. Select items from the Start menu as shown below:

- In Windows Vista, select the Start menu -> Control Panel -> Hardware and Sound -> Printers.
- In Windows XP, select the Start menu -> Control Panel -> Printers and Other Hardware -> Printers and Faxes.
- In Windows 2000, select the Start menu -> Settings -> Printers.

2. Right-click your model name icon, and then select Printing Preferences from the displayed menu.

The printer driver setup window appears.

Important

- Opening the printer driver setup window through Properties displays such tabs regarding the Windows functions as the Ports (or Advanced) tab. Those tabs do not appear when opening through Printing Preferences or application software. About tabs regarding Windows functions, refer to the user's manual for the Windows.



Advanced Guide

Advanced Guide > Printing from a Computer > Printing with Other Application Software > Overview of the Printer Driver > Canon IJ Printer Driver > Maintenance Tab

Maintenance Tab

The Maintenance tab allows you to perform printer maintenance or change the settings of the printer.

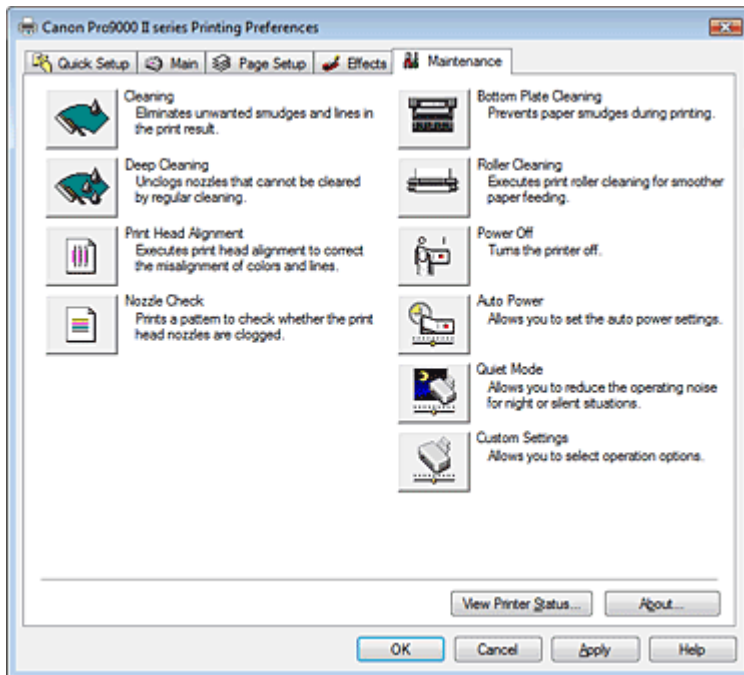

Features

- ➔ Cleaning the Print Heads
- ➔ Cleaning the Paper Feed Rollers
- ➔ Aligning the Print Head Position
- ➔ Checking the Print Head Nozzles
- ➔ Cleaning Inside the Printer
- ➔ Managing the Printer Power

Related Features

- ➔ Reducing the Printer Noise/Quiet Mode
- ➔ Changing the Printer Operation Mode



Advanced Guide

Advanced Guide > Printing from a Computer > Printing with Other Application Software > Overview of the Printer Driver > Canon IJ Status Monitor

Canon IJ Status Monitor

The Canon IJ Status Monitor is an application software that shows the status of the printer and the progress of printing on the Windows screen. You will know the status of the printer with graphics, icons, and messages.

Launching the Canon IJ Status Monitor

The Canon IJ Status Monitor launches automatically when data is sent to the printer. When launched, the Canon IJ Status Monitor appears as a button on the Task Bar.



Click the Status Monitor button displayed on the Task Bar. The Canon IJ Status Monitor appears.

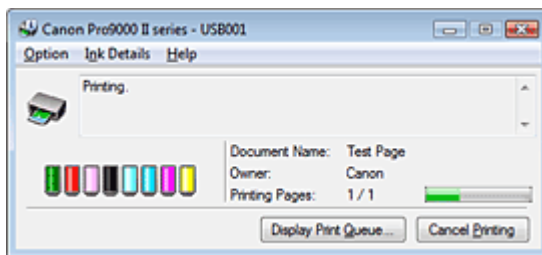

Note

- To open the Canon IJ Status Monitor when the printer is not printing, open the [printer driver setup window](#) and click View Printer Status... on the Maintenance tab.

When Errors Occur

The Canon IJ Status Monitor is automatically displayed when an error occurs (e.g., if the printer runs out of paper or if the ink is low).

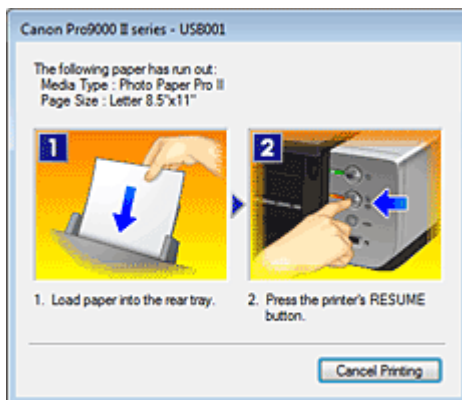

In such cases, take the appropriate action as described.

Advanced Guide

[Advanced Guide](#) > [Printing from a Computer](#) > [Printing with Other Application Software](#) > [Overview of the Printer Driver](#)
> [The Canon IJ Preview](#)

The Canon IJ Preview

The Canon IJ Preview is an application software that displays what the print result will look like before a document is actually printed.

The preview reflects the information that is set within the printer driver and allows you to check the document layout, print sequence, and number of pages. You can also change the media type settings.

If you want to display a preview before printing, open the [printer driver setup window](#), click the Main tab, and check the Preview before printing check box.

If you do not want to display a preview before printing, uncheck the check box.

Related Topic

[➡ Displaying the Print Results before Printing](#)

[Page top](#) ↑

Advanced Guide

Advanced Guide > Printing on DVD/CDs

Printing on DVD/CDs

➔ [Printing on the Label Side of DVD/CDs](#)

➔ [Troubleshooting](#)

[Page top](#) ↑

Advanced Guide

Advanced Guide > Printing on DVD/CDs > Printing on the Label Side of DVD/CDs

Printing on the Label Side of DVD/CDs

- [Items to Prepare](#)
- [Cautions When Printing on DVD/CDs](#)
- [Attaching/Removing the CD-R Tray](#)
- [Printing on the Label Side of DVD/CDs](#)
- [Printing with CD-LabelPrint from the Computer](#)
- [Printing Area](#)

[Page top](#) ↑

Advanced Guide

[Advanced Guide](#) > [Printing on DVD/CDs](#) > [Printing on the Label Side of DVD/CDs](#) > [Items to Prepare](#)

Items to Prepare

The following items are needed to print on DVD/CDs:

- **CD-R Tray**



"E" is on the upper side.

- **8 cm CD-R Adapter**



Needed only when printing on 8 cm DVD/CDs.

Attached to the CD-R Tray when shipped.

- **Printable DVD/CDs**

Obtain a 12 cm or 8 cm DVD/CD with a label surface compatible with inkjet printing.

A "printable disc" differs from regular DVD/CDs in that its label surface has been specially processed to be printed on by an inkjet printer.

[Page top](#) ↕

Advanced Guide

[Advanced Guide](#) > [Printing on DVD/CDs](#) > [Printing on the Label Side of DVD/CDs](#) > [Cautions When Printing on DVD/CDs](#)

Cautions When Printing on DVD/CDs

- Be sure to use the CD-R Tray supplied with this printer. It has an "E" on the upper side.
- Do not print on DVD/CDs that are not compatible with ink-jet printing. The ink will not dry and may cause problems with the disc itself or devices which the disc is loaded onto.
- Do not print on the DVD/CDs' recording surface. Doing so will make data recorded on DVD/CDs unreadable.
- Hold DVD/CDs by their edges. Do not touch either the label surface (printing surface) or recording surface.
- Remove any dirt from the CD-R Tray before placing DVD/CDs on the CD-R Tray. Loading discs in a dirty CD-R Tray may scratch the recording surface of the discs.
- After printing, allow the printing surface of the disc to dry naturally. Do not use hairdryers or expose the disc to direct sunlight to dry the ink. Do not touch the printing surface until the ink has dried.
- Do not attach the CD-R Tray while the printer is in operation.
- Do not remove the CD-R Tray while printing on DVD/CDs. Doing so may damage the printer, the CD-R Tray, or the disc.
- Do not get dirt or scratches on the reflectors of the CD-R Tray. The printer may not be able to recognize loading of the DVD/CD, or printing may become misaligned. If the reflectors on the CD-R Tray become dirty, wipe the reflector clean with a soft, dry cloth, taking care not to scratch the plate.
- The CD-R Tray may become dirty if software other than CD-LabelPrint or Easy-PhotoPrint EX is used.
- Always use the supplied 8 cm CD-R Adapter when printing on 8 cm DVD/CDs.
- Always close the Inner Cover after printing on DVD/CDs.

[Page top](#) ↕

Advanced Guide

Advanced Guide > Printing on DVD/CDs > Printing on the Label Side of DVD/CDs > Attaching/Removing the CD-R Tray

Attaching/Removing the CD-R Tray

Attaching the CD-R Tray

1. Gently press the  mark on the Front Tray to open the Front Tray (A), then open the Inner Cover (B).

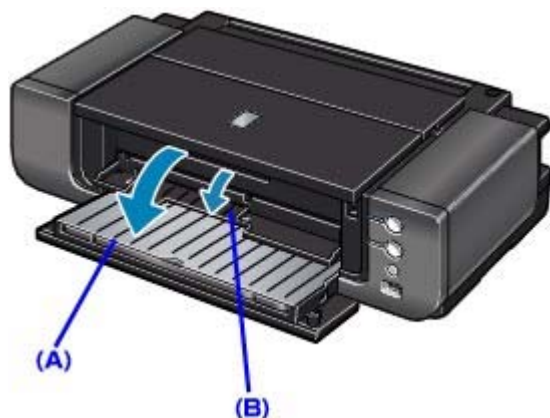

Note

- The Inner Cover does not open when the Front Tray is set in the Front paper feeding position. Return the Front Tray to the normal printing position before opening the Inner Cover.

2. Place the DVD/CD on the CD-R Tray.

Important

- Make sure that there is no dirt on the CD-R Tray before placing a DVD/CD on the CD-R Tray.
- When placing a DVD/CD on the CD-R Tray, do not touch the printing surface of the disc or the reflectors (C) on the CD-R Tray.
- When printing on an 8 cm DVD/CD, attach the supplied 8 cm CD-R Adapter. If you do not, print quality will be reduced and the disc may become damaged.

• 12 cm DVD/CD:

1. Place the disc on the CD-R Tray with the printable surface facing up.

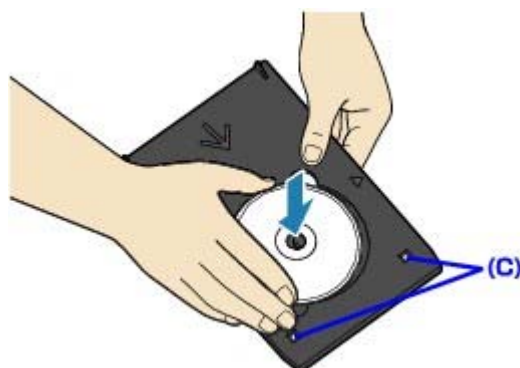

Do not touch the reflectors (C).

• 8 cm DVD/CD:

1. Align the protrusions on both edge of the 8 cm CD-R Adapter with indentations on the CD-R Tray.

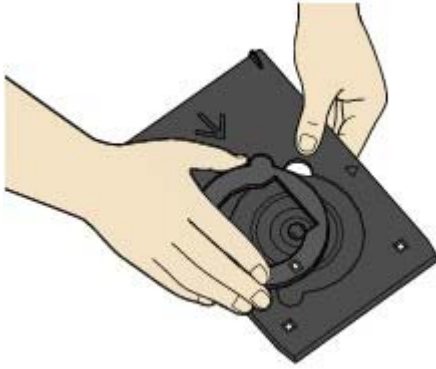

2. Place the 8 cm disc on the CD-R Tray with the printing surface facing up.

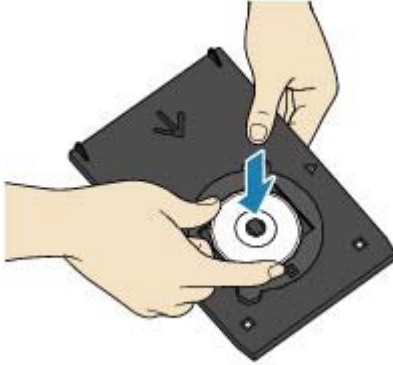

3. Attach the CD-R Tray to the printer.

Important

- Do not attach the CD-R Tray while the printer is in operation (**Power** lamp is blinking).

Note

- The printer may eject the CD-R Tray while it is preparing for printing. In this case, wait until the **Power** lamp stops blinking and stays lit, then follow the on-screen instructions to attach the CD-R Tray again.



4. Insert the CD-R Tray straight until the arrow () on the Inner Cover is almost aligned with the arrow () on the CD-R Tray.

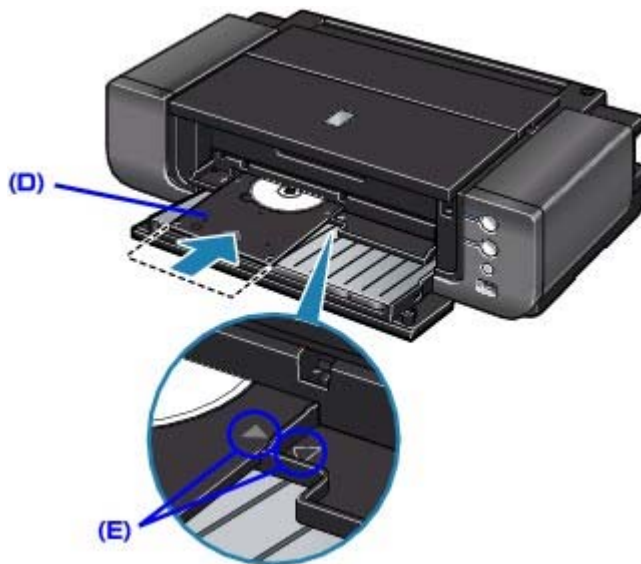

(D) Keep the CD-R Tray level when inserting it.

(E) Align the arrow (▶) on the CD-R Tray with the arrow (◀) on the Inner Cover.

Important

- Do not insert the CD-R Tray beyond the arrow (◀) on the Inner Cover.

Removing the CD-R Tray

1. Pull out the CD-R Tray.



2. Close the Inner Cover.



Important

- If the Inner Cover is opened, you cannot print on paper as it will not feed properly. Make sure that the Inner Cover is closed.

3. Remove the DVD/CD from the CD-R Tray.

Important

- Do not touch the printing surface when removing the disc from the CD-R Tray.

Note

- Dry the printing surface sufficiently before removing the disc. If you see printing on the CD-R Tray or the transparent parts on inner or outer diameter of DVD/CD, wipe them off after the printing surface has dried.

- **12 cm DVD/CD:**

1. Remove the disc from the CD-R Tray.

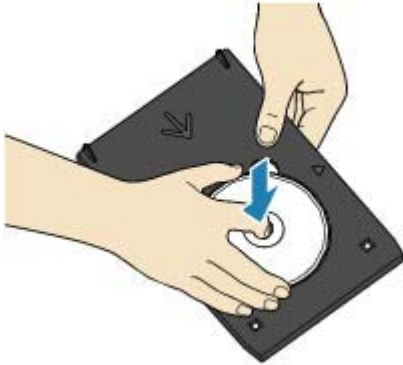

- **8 cm DVD/CD:**

1. Remove the 8 cm CD-R Adapter from the CD-R Tray.

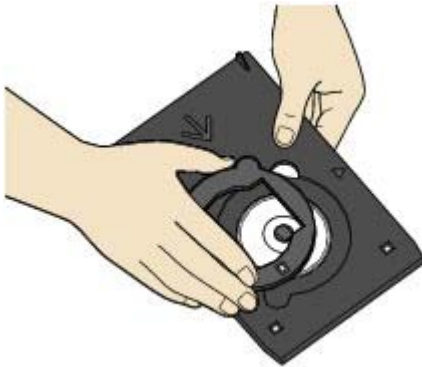

2. Remove the 8 cm disc from the CD-R Tray.



- **Storing the CD-R Tray**

You can keep the CD-R Tray in the Storage Compartment located at the center of the bottom of printer.



Insert the CD-R Tray straight.

Important

- The CD-R Tray cannot be used if it becomes warped. Be sure to keep the CD-R Tray on

a flat place.

[Page top](#) ↕

Advanced Guide

[Advanced Guide](#) > [Printing on DVD/CDs](#) > [Printing on the Label Side of DVD/CDs](#) > [Printing on the Label Side of DVD/CDs](#)

Printing on the Label Side of DVD/CDs

The CD-R Tray (supplied) allows the printing of images on printable DVD/CDs.

CD-LabelPrint is bundled application software that allows you to edit and modify data before printing. Install it on your computer to use it.

➔ [Printing with CD-LabelPrint from the Computer](#)

Note

- We recommend that you test print on an unneeded printable DVD/CD first.
-

[Page top](#) ↕

Advanced Guide

Advanced Guide > Printing on DVD/CDs > Printing on the Label Side of DVD/CDs > Printing with CD-LabelPrint from the Computer

Printing with CD-LabelPrint from the Computer

- CD-LabelPrint is bundled application software that allows you to edit and modify data before printing. Install it on your computer to use it. For information on how to install this software, refer to your setup manual.
- For details on how to print with CD-LabelPrint, refer to its manual.
If you are using a Windows computer, click Start > All Programs (or Programs in Windows 2000) > CD-LabelPrint > Manual.

If you are using a Macintosh, open the Applications folder in the location where the MP Drivers have been installed > CD-LabelPrint folder > Manual folder > double-click Manual.htm.

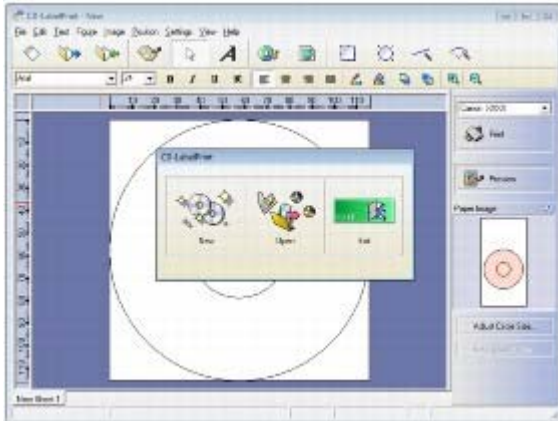

[Page top](#) ↕

Advanced Guide

Advanced Guide > Printing on DVD/CDs > Printing on the Label Side of DVD/CDs > Printing Area

Printing Area

Printable DVD/CDs

The printing area of both printable DVDs and CDs is the area excluding the 1 mm area from the internal and external diameters of the label.

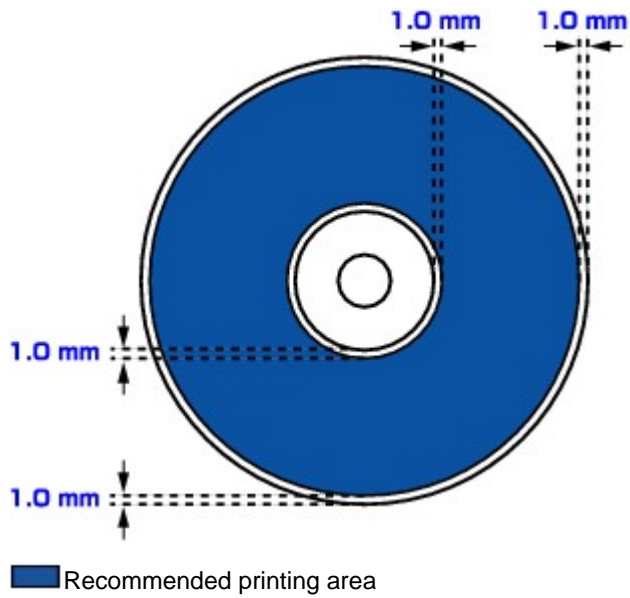

[Page top](#) ↑

Advanced Guide

Advanced Guide > Printing on DVD/CDs > Troubleshooting

Troubleshooting

- ➔ Message Appears on the Computer Screen
- ➔ Cannot Print on DVD/CDs

[Page top ↑](#)

Advanced Guide

Advanced Guide > Printing on DVD/CDs > Troubleshooting > Message Appears on the Computer Screen

Message Appears on the Computer Screen

→  **Windows** Errors About DVD/CD Printing Are Displayed

→  **Macintosh** Message: 1001 Is Displayed

→  **Macintosh** Error Number: 1002 Is Displayed

→  **Macintosh** Message: 1850 Is Displayed

Windows Errors About DVD/CD Printing Are Displayed

- **Check 1: Is the CD-R Tray placed properly?**

Open the Inner Cover, properly place the CD-R Tray again, then press the **RESUME/CANCEL** button.

Make sure that you are using the CD-R Tray supplied with the printer ("E" is on the upper side).

For details on how to place the CD-R Tray, see [Attaching/Removing the CD-R Tray](#).

- **Check 2: Is the DVD/CD placed on the CD-R Tray?**

Properly place the DVD/CD on the CD-R Tray, attach the CD-R Tray again, then press the **RESUME/CANCEL** button.

Make sure that you are using the CD-R Tray supplied with this printer ("E" is on the upper side).

For details on how to place the CD-R Tray, see [Attaching/Removing the CD-R Tray](#).

- **Check 3: Unrecognizable DVD/CD may be placed.**

Canon recommends that you use DVD/CDs specially processed to be printed on by an inkjet printer.

- **Check 4: Is the DVD/CD on the CD-R Tray already printed?**

If you place a DVD/CD on which has already been printed on the CD-R Tray, the CD-R Tray may be ejected.

In this case, change the settings of the printer driver and try printing again.

- Clear the Detects a printable disc in the CD-R tray check box in Custom Settings on the Maintenance tab, then click Send.
When printing is over, select the Detects a printable disc in the CD-R tray check box and click Send.

Note

- If the Detects a printable disc in the CD-R tray check box is cleared, printing may start without the DVD/CD loaded. Selecting the check box prevents the CD-R Tray from getting dirty.

- **Check 5: Is the Inner Cover opened when starting printing on paper, or while printing is in progress?**

Close Inner Cover, then press the **RESUME/CANCEL** button on the printer.

Do not open or close the Inner Cover while printing is in progress. This may damage the printer.

Macintosh Message: 1001 Is Displayed

- **Check: Place the CD-R Tray properly.**

Place the CD-R Tray properly, then press the **RESUME/CANCEL** button.

Make sure that you are using the CD-R Tray supplied with the printer ("E" is on the upper side).

For details on how to place the CD-R Tray, see [Attaching/Removing the CD-R Tray](#).

Error Number: 1002 Is Displayed

- **Check 1: Place the DVD/CD on the CD-R Tray properly.**

Place the DVD/CD on the CD-R Tray properly, then press the **RESUME/CANCEL** button on the printer.

Make sure that you are using the CD-R Tray supplied with the printer ("E" is on the upper side).

For details on how to place the CD-R Tray, see [Attaching/Removing the CD-R Tray](#).

- **Check 2: Unrecognizable DVD/CD may be placed.**

Canon recommends that you use DVD/CDs specially processed to be printed on by an inkjet printer.

- **Check 3: Is the DVD/CD on the CD-R Tray already printed?**

If you place a DVD/CD on which has already been printed on the CD-R Tray, the CD-R Tray may be ejected.

In this case, change the settings of the printer driver and try printing again.

- Clear the Detects a printable disc in the CD-R tray check box in Custom Settings on the Canon IJ Printer Utility dialog box, then click Send.
When printing is over, select the Detects a printable disc in the CD-R tray check box and click Send.



Note

- If the Detects a printable disc in the CD-R tray check box is cleared, printing may start without the DVD/CD loaded. Selecting the check box prevents the CD-R Tray from getting dirty.

Message: 1850 Is Displayed

- **Check: Open the Inner Cover, then place the CD-R Tray properly.**

Open the Inner Cover, place the CD-R Tray properly, then press the **RESUME/CANCEL** button.

For details on how to place the CD-R Tray, see [Attaching/Removing the CD-R Tray](#).

Advanced Guide

Advanced Guide > Printing on DVD/CDs > Troubleshooting > Cannot Print on DVD/CDs

Cannot Print on DVD/CDs

- ➔ DVD/CD Printing Does Not Start
- ➔ CD-R Tray Does Not Feed Properly
- ➔ CD-R Tray Jammed

DVD/CD Printing Does Not Start

- **Check 1: Is the CD-R Tray placed properly?**

Open the Inner Cover, properly place the CD-R Tray again, then press the **RESUME/CANCEL** button.

Use the CD-R Tray supplied with this printer ("E" is on the upper side).

For details on how to place the CD-R Tray, see [Attaching/Removing the CD-R Tray](#).

- **Check 2: Is the DVD/CD placed on the CD-R Tray?**

Place the DVD/CD on the CD-R Tray properly, then press the **RESUME/CANCEL** button on the printer.

Make sure that you are using the CD-R Tray supplied with the printer ("E" is on the upper side).

For details on how to place the CD-R Tray, see [Attaching/Removing the CD-R Tray](#).

CD-R Tray Does Not Feed Properly

- **Check 1: Is the CD-R Tray placed properly?**

Properly place the CD-R Tray again, then press the **RESUME/CANCEL** button.

Make sure that you are using the CD-R Tray supplied with the printer ("E" is on the upper side).

For details on how to place the CD-R Tray, see [Attaching/Removing the CD-R Tray](#).

- **Check 2: Unrecognizable DVD/CD may be placed.**

Canon recommends that you use DVD/CDs specially processed to be printed on by an inkjet printer.

- **Check 3: Is the DVD/CD on the CD-R Tray already printed?**

If you place a DVD/CD on which has already been printed on the CD-R Tray, the CD-R Tray may be ejected.

In this case, change the settings of the printer driver and try printing again.



- Clear the Detects a printable disc in the CD-R tray check box in Custom Settings on the Maintenance tab, then click Send.
When printing is over, select the Detects a printable disc in the CD-R tray check box and click Send.



- Clear the Detects a printable disc in the CD-R tray check box in Custom Settings on the Canon IJ Printer Utility dialog box, then click Send.
When printing is over, select the Detects a printable disc in the CD-R tray check box and click Send.



Note

- If you left cleared Detects a printable disc in the CD-R tray check box and start printing another DVD/CD, printing may start without the DVD/CD loaded. Selecting the check box prevents the CD-R Tray from getting dirty.

CD-R Tray Jammed

Pull out the CD-R Tray gently.

If the CD-R Tray cannot be pulled out, turn the printer off and then turn the printer back on again. The CD-R Tray will automatically be ejected.

When the CD-R Tray is pulled out, place the CD-R Tray again, with an "E" on the upper side, and retry printing. Place the DVD/CD properly.

➡ [Attaching/Removing the CD-R Tray](#)

If the CD-R Tray is still jammed, check if there is a problem with the DVD/CD.

➡ [CD-R Tray Does Not Feed Properly](#)

[Page top](#) ↕

Advanced Guide

Advanced Guide > Printing Photographs Directly from a Compliant Device

Printing Photographs Directly from a Compliant Device

➔ [Printing Photographs Directly from a Compliant Device](#)

[Page top](#) ↑

Advanced Guide

[Advanced Guide](#) > [Printing Photographs Directly from a Compliant Device](#) > [Printing Photographs Directly from a Compliant Device](#)

Printing Photographs Directly from a Compliant Device

- ➔ [Printing Photographs Directly from a Compliant Device](#)
- ➔ [About PictBridge Print Settings](#)

[Page top](#) ↑

Advanced Guide

Advanced Guide > Printing Photographs Directly from a Compliant Device > Printing Photographs Directly from a Compliant Device > Printing Photographs Directly from a Compliant Device

Printing Photographs Directly from a Compliant Device

You can connect a PictBridge compliant device such as a digital camera, camcorder, or mobile phone using a USB cable recommended by the device's manufacturer, and print recorded images directly without using a computer.

Note

- When printing photos with the PictBridge compliant device connected to the printer, we recommend the use of the AC adapter supplied with the device. If you are using the device battery, be sure to charge it fully.
- Depending on the model or brand of your device, you may have to select a print mode compliant with PictBridge before connecting the device. You may also have to turn on the device or select Play mode manually after connecting the device to the printer.
Perform necessary operations on the PictBridge compliant device before connecting it to this printer according to instructions given in the device's instruction manual.

1. Make sure that the printer is turned on.
2. Load paper.
 - **When printing on paper other than 14" x 17"/355.6 x 431.8 mm:**
Load paper in the Rear Tray. Refer to [Loading paper](#).
 - **When printing on 14" x 17"/355.6 x 431.8 mm paper:**
Load paper in the Front Tray. Refer to [Loading paper](#).
3. Make sure that the PictBridge compliant device is turned off.
4. Connect the PictBridge compliant device to the printer using a USB cable (A) recommended by the device's manufacturer.

The PictBridge compliant device turns on automatically.

If your device does not turn on automatically, turn it on manually.

☞ will appear on the LCD of the device when the printer is correctly connected.

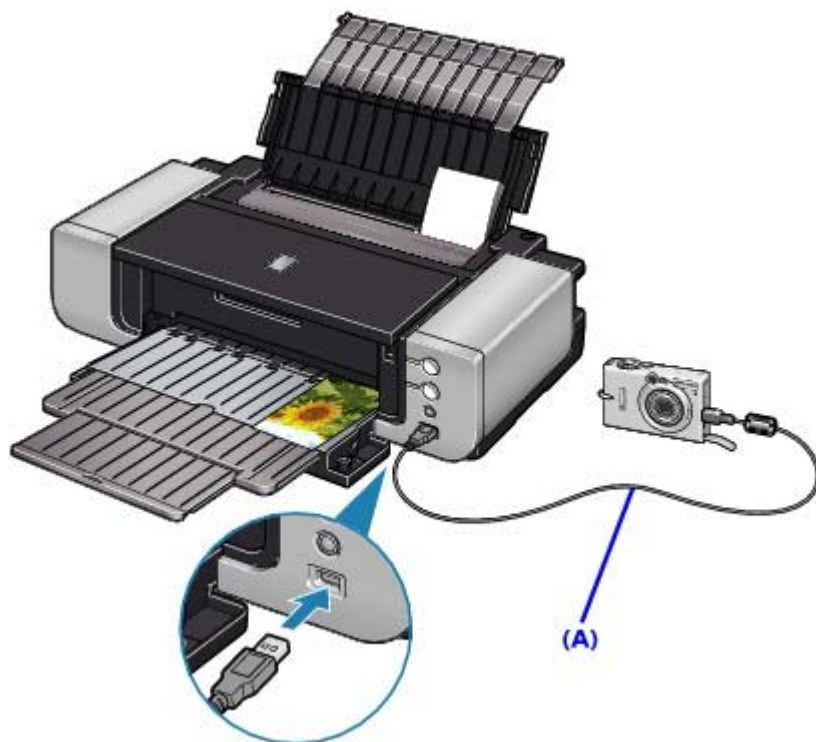

5. Specify the print settings such as the paper type and layout.

You can perform settings using the menu on the LCD of your PictBridge compliant device. Select the size and type of paper that you loaded in the printer.

[➔ Settings on a PictBridge Compliant Device](#)

6. Start printing from your PictBridge compliant device.

Important

- Never disconnect the USB cable during printing unless when explicitly allowed to by the PictBridge compliant device. When disconnecting the USB cable between the PictBridge compliant device and printer, follow the instructions given in the device's instruction manual.

[Page top ↕](#)

Advanced Guide

Advanced Guide > Printing Photographs Directly from a Compliant Device > Printing Photographs Directly from a Compliant Device > About PictBridge Print Settings

About PictBridge Print Settings

Settings on a PictBridge Compliant Device

This section describes the PictBridge function of the printer. For the print settings on a PictBridge compliant device, refer to the instructions given in the device's instruction manual.

Note

- In the following description, names of setting items are given according to those used in Canon-brand PictBridge compliant devices. Setting item names may be different depending on the brand or model of your device.
- Some setting items explained below may not be available on some devices. When you cannot change print settings on a device, the printer prints images as follows:
 Paper size: 4" x 6"/101.6 x 152.4 mm
 Paper type: Photo
 Layout: 1-up, Borderless
 Date/File No. Print: Not printed
 Image Optimize: The Photo optimizer pro function will be used for optimized printing.

The following settings can be used when printing from a PictBridge compliant device.

Paper size	4" x 6"/10 x 15 cm, 5" x 7"*1, 4" x 7.1"/ 10.1 x 18 cm*2, 8" x 10"/ 20 x 25 cm, A4, 8.5" x 11"(Letter), 10" x 12"/ 25 x 30 cm, A3, A3+/ 13" x 19", 14" x 17"/ 36 x 43 cm *1 10x15 may appear on some PictBridge compliant device. *2 Hi Vision may appear on a non-Canon brand PictBridge compliant device.
Paper type	<ul style="list-style-type: none"> ● Default: Photo Paper Pro II PR-201 ● Photo: Photo Paper Plus Glossy II PP-201/Glossy Photo Paper "Everyday Use" GP-501/ Photo Paper Glossy GP-502/Photo Paper Plus Semi-gloss SG-201/Photo Stickers*1 <p>*1 When printing on sticker paper, select 10 x 15 cm/4" x 6" in Paper size. Do not set Layout to Borderless.</p> <ul style="list-style-type: none"> ● Semi-gloss*2: Photo Paper Plus Semi-gloss SG-201 If your device does not have this setting, select Photo or Default in Paper type. ● Fast Photo: Photo Paper Pro II PR-201 ● Fine Art*2: Fine Art Paper "Photo Rag" FA-PR1 When Fine Art is selected for Paper type, borderless printing will be disabled even when Layout is set to Borderless. ● Plain: A3, A4/Letter When Paper type is set to Plain, borderless printing will be disabled even when Layout is set to Borderless. <p>*2 Available only with a Canon-brand PictBridge compliant device. (May not be available with some Canon-brand PictBridge compliant devices.)</p>
Layout	Default (Borderless), Index, Bordered, Borderless, N-up (2, 4, 9, 16)*1, 20-up*2, 35-up*3 *1 Layout compatible with A4 or Letter-sized paper and Canon-brand sticker above. A4/Letter: 4-up Photo Stickers: 2-up, 4-up, 9-up, 16-up. *2 With a Canon brand PictBridge compliant device, selecting items with "i" mark allows you to print shooting info (Exif Data) in list format (20-up) or on the margins of the specified data (1-up). (May not be available with some Canon-brand PictBridge compliant devices.) *3 Printed in 35 mm Film Style Layout (Contact Printing Layout). Available only with a Canon-brand PictBridge compliant device. (May not be available with some Canon-brand PictBridge compliant devices.)
Print date & file no.	Default (Off: No printing), Date, File No., Both, Off
Image	Default*1, On (Exif Print), Off, NR (Noise Reduction)*2, VIVID*2, Face*2, Red-Eye*2

optimize	<p>*1 Photos are optimized for printing using the Photo optimizer pro function.</p> <p>*2 Can be selected only on certain Canon-brand PictBridge compliant devices. (May not be selected depending on the device.)</p> <ul style="list-style-type: none">• With some types of Canon PictBridge compliant cameras, you can make finer color adjustments by selecting the color mode that is most suitable for what you want to achieve. Refer to the <i>Digital Photo Printing Guide</i> on-screen manual or the instruction manual provided with your Canon PictBridge compliant device. You can select the following color modes: Natural, Natural M, B/W*3, Cool tone*3, Warm tone*3 <p>*3 Depending on the image, printing problems such as uneven coloration or white streaks may occur at the top and/or bottom edges of the sheet when printing in grayscale. In this case, we recommend printing with the top and bottom margins in the print direction of the sheet set to more than 45 mm / 1.77 inches using the Easy-PhotoPrint Pro provided on the <i>Setup CD-ROM</i> or your page layout software. For details on how to print in grayscale from the computer, refer to Printing Photos in Grayscale.</p>
Trimming	Default (Off: No trimming), On (follow the camera's setting), Off

Advanced Guide

Advanced Guide > Maintenance

Maintenance

- ➔ [Cleaning Your Printer](#)
- ➔ [Performing Maintenance from a Computer](#)

[Page top](#) ↑

Advanced Guide

[Advanced Guide](#) > [Maintenance](#) > [Cleaning Your Printer](#)

Cleaning Your Printer

- ➔ [Cleaning](#)
- ➔ [Cleaning the Exterior of the Printer](#)
- ➔ [Cleaning the Protrusions Inside the Printer](#)

[Page top](#) ↑

Advanced Guide

[Advanced Guide](#) > [Maintenance](#) > [Cleaning Your Printer](#) > [Cleaning](#)

Cleaning

This section describes the cleaning procedure that is needed to maintain your printer.

Important

- Do not use tissue paper, paper towels, rough-textured cloth, or similar materials for cleaning so as not to scratch the surface. Paper tissue powder or fine threads may remain inside the printer and cause problems such as print head blockage and poor printing results. Be sure to use a soft cloth.
- Never use volatile liquids such as thinners, benzene, acetone, or any other chemical cleaner to clean the printer, as this may cause a malfunction or damage the printer's surface.

➔ [Cleaning the Exterior of the Printer](#)

➔ [Cleaning the Protrusions Inside the Printer](#)

[Page top](#) ↕

Advanced Guide

[Advanced Guide](#) > [Maintenance](#) > [Cleaning Your Printer](#) > [Cleaning the Exterior of the Printer](#)

Cleaning the Exterior of the Printer

Be sure to use a soft cloth such as eyeglasses cleaning cloth and wipe off dirt on the surface gently. Smooth out wrinkles on the cloth if necessary before cleaning.

Important

- Be sure to turn off the power and disconnect the power plug before cleaning the printer.
- Do not use tissue paper, paper towels, rough-textured cloth, or similar materials, as this may scratch the surface.

[Page top](#) 

Advanced Guide

Advanced Guide > Maintenance > Cleaning Your Printer > Cleaning the Protrusions Inside the Printer

Cleaning the Protrusions Inside the Printer

If protrusions inside the printer are stained, wipe off any ink from the protrusions using a cotton swab or the like.

Important

- Be sure to turn off the power and disconnect the power plug before cleaning the printer.
- Do not touch (A) and (B) inside of the printer when cleaning.

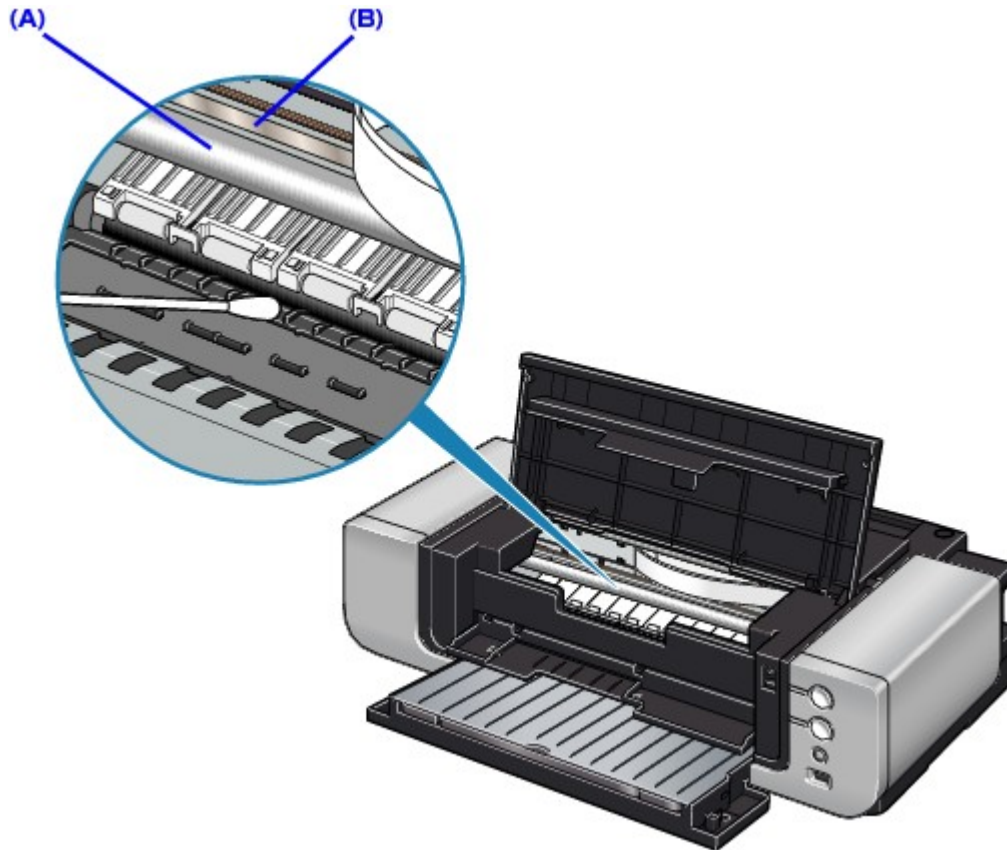

Advanced Guide

Advanced Guide > Maintenance > Performing Maintenance from a Computer

Performing Maintenance from a Computer

- ➔ [Cleaning the Print Heads](#)
- ➔ [Cleaning the Paper Feed Rollers](#)
- ➔ [Aligning the Print Head Position](#)
- ➔ [Manual Print Head Alignment](#)
- ➔ [Checking the Print Head Nozzles](#)
- ➔ [Cleaning Inside the Printer](#)

[Page top](#) ↑

Advanced Guide

Advanced Guide > Maintenance > Performing Maintenance from a Computer > Cleaning the Print Heads

Cleaning the Print Heads

The print head cleaning function allows you to remove any blockages in the print head nozzles. Perform print head cleaning if printing is faint or a specific color fails to print, even though there is enough ink.

The procedure for cleaning the print heads is as follows:



Cleaning

1. Open the [printer driver setup window](#)

2. Click Cleaning on the Maintenance tab

The Print Head Cleaning dialog box opens. Follow the instruction shown in the dialog box. Click Initial Check Items to display the items you need to check before performing Cleaning.

3. Execute cleaning

Make sure that the printer is on and then click Execute.
Print head cleaning starts.

4. Complete cleaning

The Nozzle Check dialog box opens after the confirmation message.

5. Check the results

To check whether the print quality has improved, click Print Check Pattern. To cancel the check process, click Cancel.

If cleaning the head once does not resolve the print head problem, clean it once more.



Deep Cleaning

Deep Cleaning is more thorough than Cleaning. Perform deep cleaning when two cleaning attempts do not resolve the print head problem.

1. Open the [printer driver setup window](#)

2. Click Deep Cleaning on the Maintenance tab

The Deep Cleaning dialog box opens. Follow the instruction shown in the dialog box. Click Initial Check Items to display the items you need to check before performing Deep Cleaning.

3. Execute deep cleaning

Make sure that the printer is on and then click Execute.
Click OK when the confirmation message appears.
Print head deep cleaning starts.

4. Complete deep cleaning

The Nozzle Check dialog box opens after the confirmation message.

5. Check the results

To check whether the print quality has improved, click Print Check Pattern. To cancel the check

process, click Cancel.

Important

- Cleaning consumes a small amount of ink. Deep Cleaning consumes a larger amount of ink than Cleaning. Cleaning the print heads frequently will rapidly deplete your printer's ink supply. Consequently, perform cleaning only when necessary.

Note

- If there is no sign of improvement after Deep Cleaning, switch off the printer, wait 24 hours, and then perform Deep Cleaning again. If there is still no sign of improvement, the ink may have run out or the print head may be worn. For details on the remedial action to be taken, see "[Printer Moves But Ink Is Not Ejected](#)."

Related Topic

[➔ Checking the Print Head Nozzles](#)

[Page top](#) 

Advanced Guide

[Advanced Guide](#) > [Maintenance](#) > [Performing Maintenance from a Computer](#) > [Cleaning the Paper Feed Rollers](#)

Cleaning the Paper Feed Rollers

The feed roller cleaning function allows you to clean the paper feed roller. Perform feed roller cleaning when there are paper particles sticking to the paper feed roller and paper is not fed properly.

The procedure for cleaning the feed rollers is as follows:



Roller Cleaning

1. Prepare the printer

Remove all sheets of paper from the paper source from which paper could not be properly fed.

2. Open the [printer driver setup window](#)

3. Click Roller Cleaning on the Maintenance tab

The Roller Cleaning dialog box opens.

4. Select Rear Tray or Cassette, and click OK

The confirmation message appears.

5. Execute paper feed roller cleaning

Make sure that the printer is on and click OK.
Paper feed roller cleaning starts.

6. Complete paper feed roller cleaning

After the rollers have stopped, follow the instruction in the message, load three sheets of plain paper into the selected paper source of the printer, and click OK.

Paper will be ejected and feed roller cleaning will be completed.

Advanced Guide

Advanced Guide > Maintenance > Performing Maintenance from a Computer > Aligning the Print Head Position

Aligning the Print Head Position

Print head alignment corrects the installation positions of the print head and improves deviated colors and lines.

This printer supports two head alignment methods: automatic head alignment and manual head alignment. Normally, the printer is set for automatic head alignment.

If the printing results are unsatisfactory even after you execute automatic head alignment, see "[Manual Print Head Alignment](#)," and execute manual head alignment. To change to the manual head alignment, click Custom Settings on the Maintenance tab, and then check the Align heads manually check box.

The procedure for performing print head alignment is as follows:



Print Head Alignment

1. Open the [printer driver setup window](#)
2. Click Print Head Alignment on the Maintenance tab
The Start Print Head Alignment dialog box opens.
3. Load paper in the printer
Load two sheets of A4 size or Letter size plain paper into the rear tray.
4. Execute head alignment
Make sure that the printer is on and click Align Print Head.
Follow the instruction in the message.

Note

- To check the current setting before you adjust the print head position, click Print Alignment Value.

Advanced Guide

Advanced Guide > Maintenance > Performing Maintenance from a Computer > Manual Print Head Alignment

Manual Print Head Alignment

This section describes how to align the Print Head manually.

If the results of Automatic Print Head Alignment are not satisfactory, follow the procedure below to perform Manual Print Head Alignment to precisely align the Print Head.

For details on performing Automatic Print Head Alignment, see [Routine Maintenance](#).

Note

- Be sure to load paper in the Rear Tray. The Front Tray cannot be used for Manual Print Head Alignment.
- Close the Inner Cover if it is open.

Windows

1. Make sure that the printer is turned on.
2. Load two sheets of A4 or Letter-sized plain paper in the Rear Tray.
3. Gently press the  mark on the Front Tray to open the Front Tray and extend the Front Tray Extension.
4. Print the pattern.
 1. Open the printer properties dialog box.
 - ➔ [Open the Printer Properties Dialog Box through the Start Menu](#)
 2. Click the Maintenance tab, then Custom Settings.
 3. Select the Align heads manually check box, then click Send.
 4. Confirm the displayed message and click OK.
 5. In the Maintenance sheet click Print Head Alignment.
 6. Confirm the displayed message and click Align Print Head.

Important

- Do not open the Top Cover while printing is in progress.

Note

- Clicking Print Alignment Value prints the current settings and finishes Print Head Alignment.

7. After the pattern is printed, click Yes.

The dialog for entering a print head alignment value is displayed.
5. Look at the first printout and adjust the print head position.
 1. Check the printed patterns and select the number of the pattern in column A that has the least noticeable vertical streaks.



Note

- If it is difficult to pick the best pattern, pick the setting that produces the least noticeable vertical white streaks.



- (A) Less noticeable vertical white streaks
 (B) More noticeable vertical white streaks

2. Repeat the procedure until you finish inputting the pattern number for column H, then click OK.

Note

- If it is difficult to pick the best pattern in column H, pick the setting that produces the least noticeable vertical white streaks.



- (C) Less noticeable vertical white streaks
 (D) More noticeable vertical white streaks

3. Confirm the displayed message and click OK.
 The second pattern is printed.

Important

- Do not open the Top Cover while printing is in progress.

6. Look at the second printout and adjust the print head position.

1. Check the printed patterns and select the number of the pattern in column I that has the least noticeable vertical streaks.

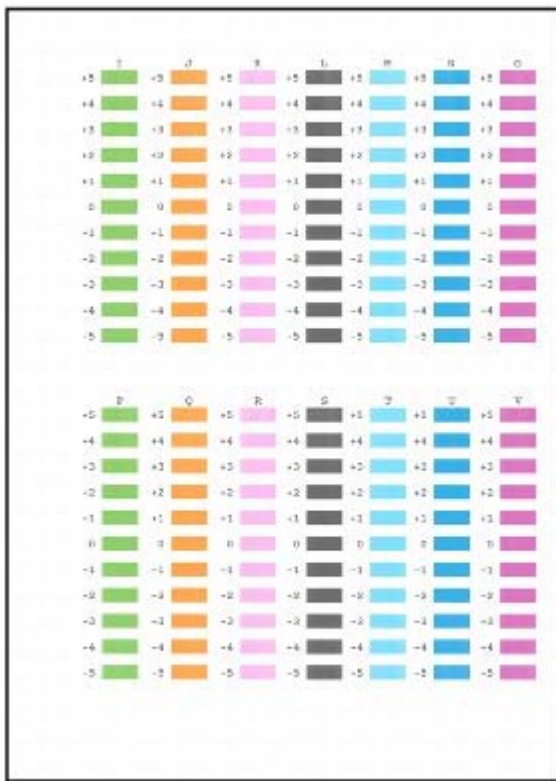

Note

- If it is difficult to pick the best pattern, pick the setting that produces the least noticeable vertical white streaks.



- (E) Less noticeable vertical white streaks
 (F) More noticeable vertical white streaks

2. Repeat the procedure until you finish inputting the pattern number for column V, then click OK.
3. Confirm the displayed message and click OK.

Macintosh

1. Make sure that the printer is turned on.
2. Load two sheets of A4 or Letter-sized plain paper in the Rear Tray.
3. Gently press the mark on the Front Tray to open the Front Tray and extend the Front Tray Extension.
4. Print the pattern.
 1. Open the Canon IJ Printer Utility dialog box.
 ➔ [Opening the Canon IJ Printer Utility \(Macintosh\)](#)
 2. Select Custom Settings in the pop-up menu.
 3. Select the Align heads manually check box, then click Send.
 4. Confirm the displayed message and click OK.
 5. Select Test Print in the pop-up menu.
 6. Click Print Head Alignment.
 7. Confirm the displayed message and click Align Print Head.
 The dialog for entering a print head alignment value is displayed.

Important

- Do not open the Top Cover while printing is in progress.

Note

- Clicking Print Alignment Value prints the current settings and finishes Print Head Alignment.

5. Look at the first printout and adjust the print head position.

- Check the printed patterns and select the number of the pattern in column A that has the least noticeable vertical streaks.

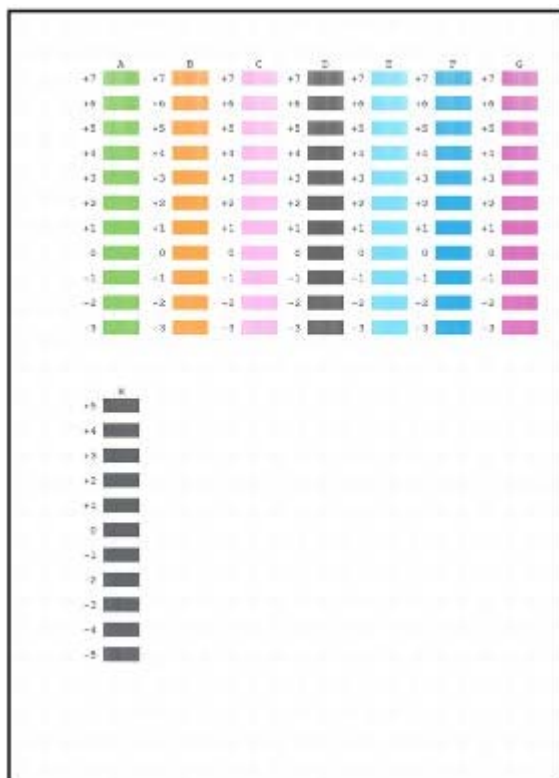

Note

- If it is difficult to pick the best pattern, pick the setting that produces the least noticeable vertical white streaks.



- (A) Less noticeable vertical white streaks
 (B) More noticeable vertical white streaks

- Repeat the procedure until you finish inputting the pattern number for column H, then click Send.

Note

- If it is difficult to pick the best pattern in column H, pick the setting that produces the least noticeable vertical white streaks.

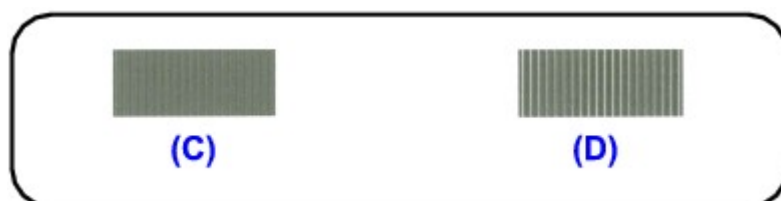

- (C) Less noticeable vertical white streaks
- (D) More noticeable vertical white streaks

3. Confirm the displayed message and click OK.
The second pattern is printed.

Important

- Do not open the Top Cover while printing is in progress.

6. Look at the second printout and adjust the print head position.

1. Check the printed patterns and select the number of the pattern in column I that has the least noticeable vertical streaks.

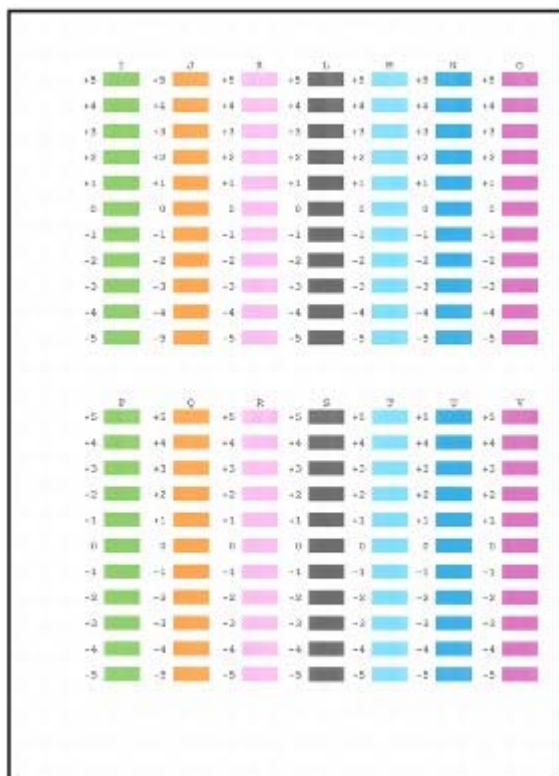

Note

- If it is difficult to pick the best pattern, pick the setting that produces the least noticeable vertical white streaks.



- (E) Less noticeable vertical white streaks
- (F) More noticeable vertical white streaks

2. Repeat the procedure until you finish inputting the pattern number for column V, then click Send.

Advanced Guide

Advanced Guide > Maintenance > Performing Maintenance from a Computer > Checking the Print Head Nozzles

Checking the Print Head Nozzles

The nozzle check function allows you to check whether the print heads are working properly by printing a nozzle check pattern. Print the pattern if printing becomes faint, or if a specific color fails to print.

The procedure for printing a nozzle check pattern is as follows:



Nozzle Check

1. Open the printer driver setup window

2. Click Nozzle Check on the Maintenance tab

The Nozzle Check dialog box opens.

To display a list of items that you should check before printing the check pattern, click Initial Check Items.

3. Load paper in the printer

Load a sheet of A4 size or Letter size plain paper into the rear tray.

4. Print a nozzle check pattern

Make sure that the printer is on and click Print Check Pattern.

The nozzle check pattern is printed.

Click OK when the confirmation message appears.

The Pattern Check dialog box opens.

5. Check the print result

Check the print result. If the print result is normal, click Exit.

If the print result is smudged or if there are any unprinted sections, click Cleaning to clean the print head.

Related Topic

➔ [Cleaning the Print Heads](#)

[Page top](#) ↑

Advanced Guide

Advanced Guide > Maintenance > Performing Maintenance from a Computer > Cleaning Inside the Printer

Cleaning Inside the Printer

The bottom plate cleaning function allows you to prevent smudges on the back side of the paper. Perform bottom plate cleaning before you execute duplex printing. Also perform bottom plate cleaning if ink smudges caused by something other than print data appear on the printed page.

The procedure for performing bottom plate cleaning is as follows:



Bottom Plate Cleaning

1. Open the [printer driver setup window](#)
2. Click Bottom Plate Cleaning on the Maintenance tab

The Bottom Plate Cleaning dialog box opens.

3. Load paper in the printer

As instructed in the dialog box, fold the A4 size or Letter size plain paper in half lengthwise, and then unfold the sheet.

Load the paper into the rear tray in the landscape orientation with the crest of the crease facing down.

4. Perform the bottom plate cleaning

Make sure that the printer is on and click Execute. Bottom plate cleaning starts.

[Page top](#) ↑

Advanced Guide

Advanced Guide > Changing the Printer Settings

Changing the Printer Settings

➔ [Changing Printer Settings from Your Computer](#)

[Page top](#) ↑

Advanced Guide

[Advanced Guide](#) > [Changing the Printer Settings](#) > [Changing Printer Settings from Your Computer](#)

Changing Printer Settings from Your Computer

- ➔ [Changing the Print Options](#)
- ➔ [Registering a Frequently Used Printing Profile](#)
- ➔ [Managing the Printer Power](#)
- ➔ [Reducing the Printer Noise](#)
- ➔ [Changing the Printer Operation Mode](#)

[Page top](#) ↑

Advanced Guide

Advanced Guide > Changing the Printer Settings > Changing Printer Settings from Your Computer > Changing the Print Options

Changing the Print Options

You change detailed print driver settings for print data that is sent from an application software. Specify this option if you encounter print failures such as part of an image data being cut off.

The procedure for changing the print options is as follows:

1. Open the [printer driver setup window](#)
2. Click Print Options... on the Page Setup tab

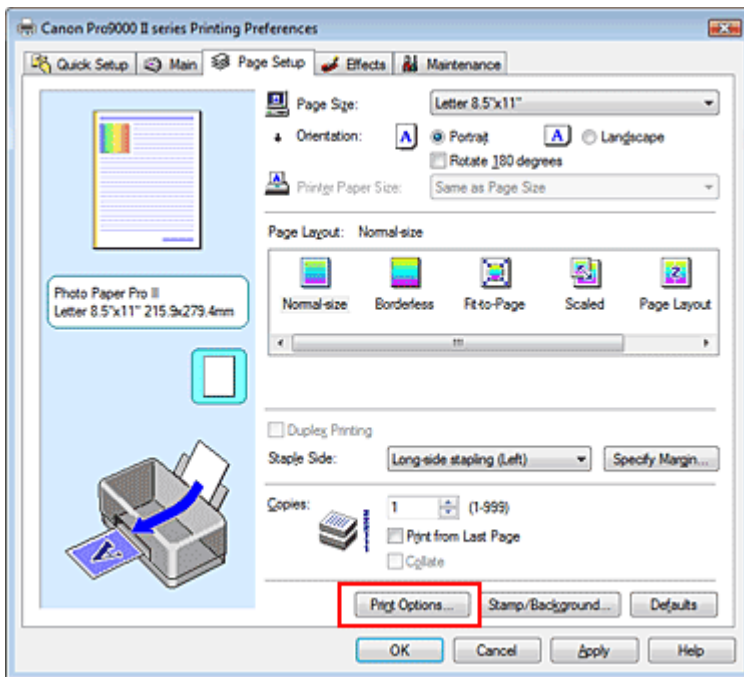

The Print Options dialog box opens.

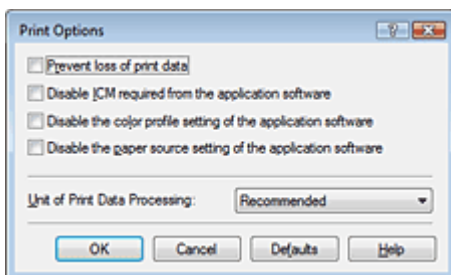

3. Change the individual settings

If necessary, change the setting of each item, and then click OK.

The Page Setup tab is displayed again.

Advanced Guide

Advanced Guide > Changing the Printer Settings > Changing Printer Settings from Your Computer > Registering a Frequently Used Printing Profile

Registering a Frequently Used Printing Profile

You can register the frequently used printing profile to Commonly Used Settings on the Quick Setup tab. Unnecessary printing profiles can be deleted at any time.

The procedure for registering a printing profile is as follows:

Registering a Printing Profile

1. Open the printer driver setup window

2. Set the necessary items

From Commonly Used Settings on the Quick Setup tab, select the printing profile to be used and change the settings after Additional Features, as necessary.

You can also set necessary items on the Main, Page Setup, and Effects tab.

3. Click Save...

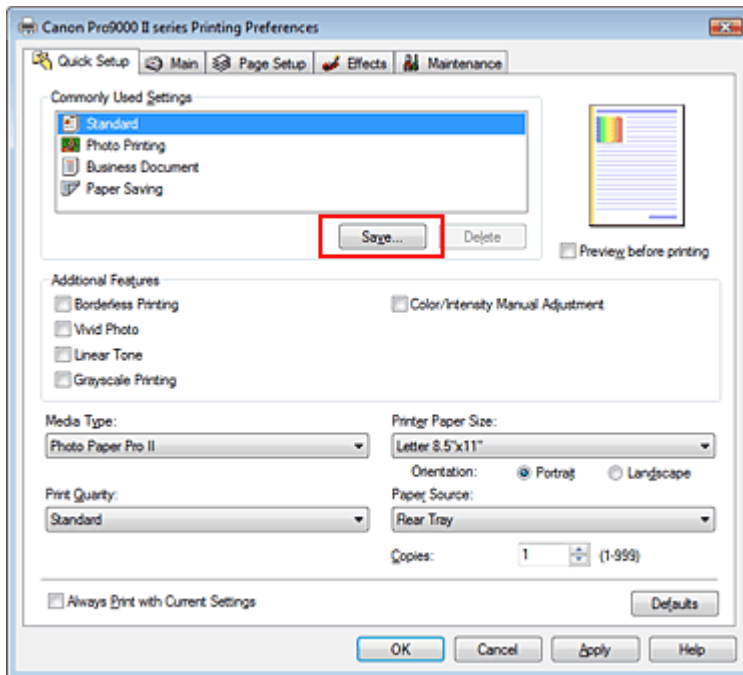

The Save Commonly Used Settings dialog box opens.

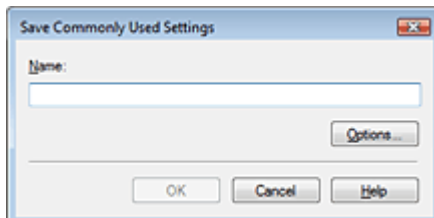

4. Save the settings

Set Name, then click OK. Set the items in Options..., as necessary. The printing profile is saved, and the Quick Setup tab is displayed again.

The name and icon are added to the Commonly Used Settings list.

Note

- If you install the printer driver again or upgrade the version of the printer driver, the print settings you registered will be deleted from Commonly Used Settings.

Registered print settings cannot be saved and preserved. In this case, register the print settings again.

Deleting Unnecessary Printing Profile

1. Select the printing profile to be deleted

Select the printing profile you want to delete from the Commonly Used Settings list on the Quick Setup tab.

2. Delete the printing profile

Click Delete. When the confirmation message appears, click OK.
The selected printing profile is deleted from the Commonly Used Settings list.

Note

- Printing profiles that are registered in the initial settings cannot be deleted.
-

Advanced Guide

Advanced Guide > Changing the Printer Settings > Changing Printer Settings from Your Computer > Managing the Printer Power

Managing the Printer Power

This function allows you to manage the printer power from the printer driver.

The procedure for managing the printer power is as follows:



Power Off

The Power Off function turns off the printer. If you use this function, you will not be able to turn the printer on from the printer driver.

1. Open the [printer driver setup window](#)

2. Execute power off

Click Power Off on the Maintenance tab. When the confirmation message appears, click OK.

The printer power switches off, and the Maintenance tab is displayed again.



Auto Power

The Auto Power Off function automatically turns off the printer when print data has not been received from the computer for a specified period of time.

The Auto Power On function automatically turns on the printer upon reception of print data.

1. Open the [printer driver setup window](#)

2. Make sure that the printer is on and then click Auto Power on the Maintenance tab

The Auto Power Settings dialog box opens.

Note

- If the printer is off or bi-directional communication is disabled, a message may appear because the computer cannot collect the printer status.
If this happens, click OK to display the most recent settings specified on your computer.

3. If necessary, complete the following settings:

Auto Power On

Specifying Enable from the list will turn the printer on upon receipt of print data.

Auto Power Off

Specify time from the list. If this time lapses without any print data being received, the printer is turned off automatically.

4. Transmit the settings

Click Send. When the confirmation message appears, click OK.

The Maintenance tab is displayed again.

The Auto Power On/Off function is enabled. If you want to disable this function, select Disable from the list according to the same procedure.

Note

- When the printer is turned off, the Status Monitor message varies depending on the Auto Power On setting.
When Auto Power On is enabled, "Printer is standing by" is displayed. When Auto Power On is

disabled, "Printer is offline" is displayed.

[Page top ↑](#)

Advanced Guide

Advanced Guide > Changing the Printer Settings > Changing Printer Settings from Your Computer > Reducing the Printer Noise

Reducing the Printer Noise

This function allows you to reduce the operating noise of the printer. Select if you wish to reduce the operating noise of the printer at night, etc.
Using this function may lower the print speed.

The procedure for changing the quiet mode settings is as follows:



Quiet Mode

1. Open the [printer driver setup window](#)
2. Click Quiet Mode on the Maintenance tab

The Quiet Mode dialog box opens.

3. Set the silent function

If necessary, specify one of the following items:

Do not use quiet mode

The operating noise of the printer is at normal volume.

Always use quiet mode

Select this option when you wish to reduce the operating noise of the printer.

Use quiet mode within specified time

The operating noise of the printer can be reduced during a specified period of time.
Set the Start time and End time when you wish the quiet mode to be activated.

Important

- The time specified in Start time and in End time must be different.

4. Transmit the settings

Make sure that the printer is on and click Send.
Click OK when the confirmation message appears.
The selected settings are enabled hereafter.

Note

- Depending on print quality settings, effects of the quiet mode may be less.

Advanced Guide

Advanced Guide > Changing the Printer Settings > Changing Printer Settings from Your Computer > Changing the Printer Operation Mode

Changing the Printer Operation Mode

This function allows you to change the printer settings, as necessary.

The procedure for configuring Custom Settings is as follows:



Custom Settings

1. Open the [printer driver setup window](#)
2. Make sure that the printer is on, and then click Custom Settings on the Maintenance tab

The Custom Settings dialog box opens.

Note

- If the printer is off or bi-directional communication is disabled, a message may appear because the computer cannot collect the printer status.
If this happens, click OK to display the most recent settings specified on your computer.

3. If necessary, complete the following settings:

Prevent paper abrasion

The printer can increase the gap between the print head and the paper during high-density printing to prevent paper abrasion.

Check this check box to use this function.

Align heads manually

The Print Head Alignment function on the Maintenance tab is normally set to automatic head alignment, but you can change it to manual head alignment. If the printing results are unsatisfactory even after you execute automatic head alignment, see "[Manual Print Head Alignment](#)," and execute manual head alignment.

Check this check box to perform the manual head alignment.

Detect Paper Width

Detects the width of paper loaded in the printer when printing.

If the paper width detected by the printer is narrower than the width of the paper specified in Paper Size on the Page Setup tab, a message is displayed and printing is stopped.

Check this check box to detect the paper width.

Important

- If you use a custom paper size to print, specify the size of paper correctly in the Custom Paper Size dialog box.
If an error message appears when you use the specified paper size, uncheck the Detect Paper Width check box.

Ink Drying Wait Time

You can set the length of the printer rest time until printing of the next page begins. Moving the slider to the right increases the pause time and moving the slider to the left decreases the time.

If the paper gets stained because the next page is ejected before the ink on the printed page dries, increase the ink drying wait time.

Reducing the ink drying wait time speeds up printing.

4. Transmit the settings

Click Send, and click OK when the confirmation message appears.

After that, the printer operates with the modified settings.

Advanced Guide

Advanced Guide > Troubleshooting

Troubleshooting

- ➔ If an Error Occurs
- ➔ The Printer Cannot Be Powered On
- ➔ Alarm Lamp Flashes Orange
- ➔ Power Lamp Flashes Green and Alarm Lamp Flashes Orange Alternately
- ➔ Cannot Install the Printer Driver
- ➔ Cannot Install the Application Program
- ➔ Cannot Connect to Computer Properly
- ➔ Print Results Not Satisfactory
- ➔ Printing Does Not Start
- ➔ Printing Stops Before It Is Completed
- ➔ Printer Moves But Ink Is Not Ejected
- ➔ Printing Speed Is Not as Fast as Expected
- ➔ Print Head Holder Does Not Move to the Position for Replacing
- ➔ Paper Does Not Feed Properly
- ➔ Paper Does Not Feed from the Paper Source Specified in the Printer Driver
- ➔ Paper Jams
- ➔ Message Appears on the Computer Screen
- ➔ For Windows Users
- ➔ Error Message Appears on a PictBridge Compliant Device
- ➔ FAQs
- ➔ If You Cannot Resolve the Problem
- ➔ Instructions for Use (Printer Driver)

[Page top](#) ↑

Advanced Guide

Advanced Guide > Troubleshooting > If an Error Occurs

If an Error Occurs

When an error occurs in printing such as the printer is out of paper or paper is jammed, a troubleshooting message is displayed automatically. Take the appropriate action described in the message. The message may vary depending on the version of your operating system.

Windows

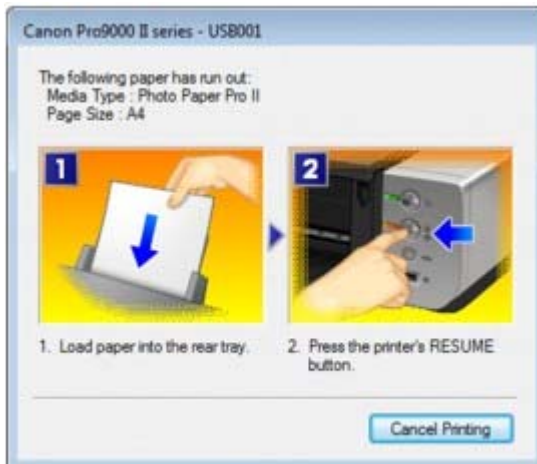

Macintosh

- In Mac OS X v.10.5.x:

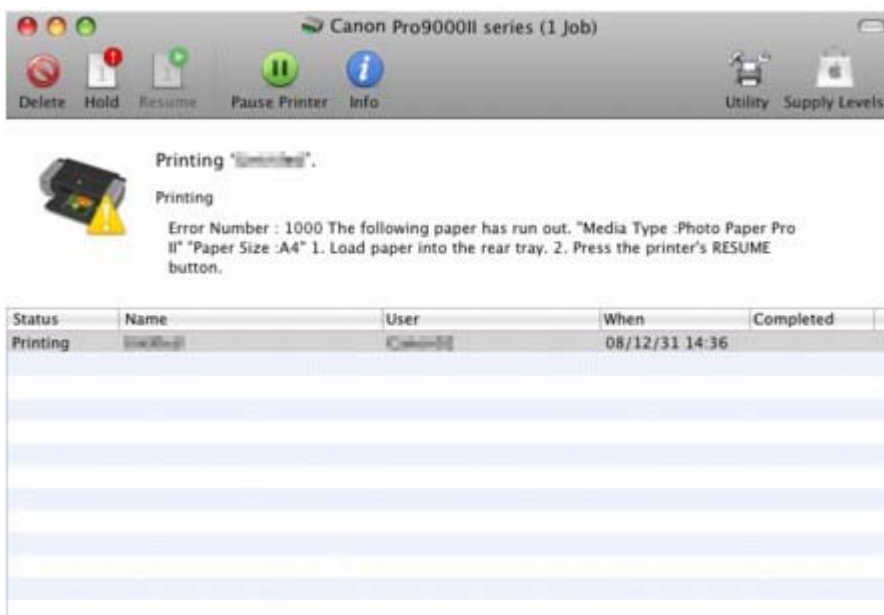

- In Mac OS X v.10.4.x or Mac OS X v.10.3.9:



Advanced Guide

[Advanced Guide](#) > [Troubleshooting](#) > [The Printer Cannot Be Powered On](#)

The Printer Cannot Be Powered On

- **Check 1: Press the Power button.**
- **Check 2: Make sure that the power plug is securely plugged into the Power Cord Connector of the printer, then turn it back on.**
- **Check 3: Unplug the printer from the power supply, then plug the printer back in and turn the printer back on after leaving it for at least 5 minutes.**

If the problem is not resolved, contact the service center.

[Page top](#) ↕

Advanced Guide

Advanced Guide > Troubleshooting > Alarm Lamp Flashes Orange

Alarm Lamp Flashes Orange

When a printer error occurs, the Alarm lamp flashes orange as shown below. The number of flashes indicates the type of error that has occurred. Count the flashes and take the appropriate action to correct the error.



(A) Note the number of flashes

(B) Flashes repeatedly

Note

■ Alarm Lamp Is Lit Orange

The printer is not ready to feed paper from the Front Tray yet. Load the paper correctly in the Front Tray and press the **RESUME/CANCEL** button on the printer. Refer to [Loading Paper](#) for details about how to load the paper correctly in the Front Tray.

Number of flashes/Cause	Action
Two flashes: Paper does not feed in the Rear Tray.	Reload paper to the Rear Tray and press the RESUME/CANCEL button.
Three flashes: Front Tray or Front Feed Support is closed./Paper jams.	<p>If the Front Tray is closed, open it. The printer resumes printing.</p> <p>If the Front Feed Support is closed when printing from the Front Tray, open it and press the RESUME/CANCEL button on the printer.</p> <p>If the error still remains when the Front Tray or the Front Feed Support is opened, paper may be jammed. Remove the jammed paper, reload paper in the printer, and then press the RESUME/CANCEL button.</p> <p>➔ Paper Jams</p>
Four flashes: Ink tank is not installed properly./Ink may have run out.	<ul style="list-style-type: none"> • If the lamp on the ink tank is not lit, the ink tank may not be installed properly. Install an appropriate ink tank. • If the lamp on the ink tank is flashing, ink may have run out. Replacing the ink tank is recommended. <p>If printing is in progress and you want to continue printing, press the RESUME/CANCEL button with the ink tank installed. Then printing can continue. Replacing the ink tank is recommended after the printing. The printer may be damaged if printing is continued under the ink out condition.</p> <p>➔ Routine Maintenance</p>

Note

- If multiple ink lamps are flashing, refer to [Routine Maintenance](#) and confirm the status of each ink tank.

<p>Five flashes: Print Head is not installed./Print Head is defective.</p>	<p>Follow the directions given in your setup manual to install the Print Head. If the Print Head is already installed, remove the Print Head once and then reinstall it. If the error is still not resolved, the Print Head may be damaged. Contact the service center.</p>
<p>Six flashes: The Inner Cover is opened.</p>	<p>If the Inner Cover is open when starting printing on paper, close the Inner Cover, then press the RESUME/CANCEL button on the printer.</p>
<p>Seven flashes: Ink tank is not installed in the correct position.</p>	<ul style="list-style-type: none"> • Some ink tanks are not installed in the correct position. (The lamps on the ink tanks flash.) • More than one ink tanks of the same color are installed. (The lamps on the ink tanks flash.) <p>Confirm that the ink tanks are installed in the appropriate positions. ➔ Routine Maintenance</p>
<p>Eight flashes: Ink absorber is almost full.</p>	<p>The ink absorber is almost full. Press the printer's RESUME/CANCEL button to continue printing. Contact the service center.</p>
<p>Nine flashes: The printer has not received a response from the digital camera./The digital camera or digital video camcorder connected is not compatible with this printer.</p>	<ul style="list-style-type: none"> • Check the device connected to the printer. Printing photos directly is possible only with a PictBridge compliant device. • A communication time out occurs if an operation takes too long or if it takes too much time to send data. This may cancel printing. In such cases, disconnect and reconnect the USB cable. When printing from a PictBridge compliant device, depending on the model or brand of your device, you may have to select a PictBridge compliant print mode on the device before connecting it to the printer. You may also have to turn on your device or select Play mode manually after connecting the device to the printer. Perform necessary operations before connecting your device referring to its instruction manual. <p>If the error is still not resolved, check if you can print another photograph.</p>
<p>Ten flashes: The Front Tray is not set to its correct position./The Front Tray was moved during printing.</p>	<p>When printing from the Rear Tray, return the Front Tray to its normal printing position, make sure that paper is loaded in the Rear Tray, then press the RESUME/CANCEL button on the printer to resume printing. Refer to Loading Paper for details about how to return the Front Tray to its normal printing position. If you have moved the Front Tray during printing, return the Front Tray to the correct position, then press the RESUME/CANCEL button on the printer and try printing again. Do not move the Front Tray during printing.</p>
<p>Eleven flashes: Automatic Print Head alignment failed./The Page Size setting does not match the size of the paper loaded in the printer.</p>	<p>When performing Automatic Print Head Alignment:</p> <ul style="list-style-type: none"> • Print Head nozzles are clogged. Press the RESUME/CANCEL button to dismiss the error, and print the nozzle check pattern to check the status of the Print Head. ➔ Routine Maintenance • Paper of size other than A4 or Letter is loaded in the Rear Tray. Press the RESUME/CANCEL button to dismiss the error, then load two sheets of A4/Letter-sized plain paper in the Rear Tray. For Automatic Print Head Alignment, always load paper on the Rear Tray. • The Paper Output Slot is exposed to strong light. Press the RESUME/CANCEL button to dismiss the error, and then adjust your operating environment and/or the position of the printer so that the Paper Output Slot is not exposed directly to strong light. <p>After carrying out the above measures, if the problem</p>

	<p>continues after aligning the Print Head again, press the RESUME/CANCEL button to dismiss the error, and then perform Manual Print Head Alignment.</p> <p>➔ Manual Print Head Alignment</p> <p>When printing the nozzle check pattern or performing Manual Print Head Alignment:</p> <p>Other than A4/Letter-sized paper is loaded.</p> <p>Press the RESUME/CANCEL button on the printer to clear the error, and load A4/Letter-sized plain paper in the Rear Tray. Then try performing again.</p> <p>When performing an ordinary print job:</p> <ul style="list-style-type: none"> • Press the RESUME/CANCEL button on the printer to clear the error. Then check the Page Size setting in the Page Setup sheet (Windows) or the Page Setup dialog box (Macintosh) in the printer driver and load paper that is the same size as the setting and try printing again. • If this error occurs even when the paper loaded in the printer is the same as the setting, set the printer driver not to detect the width of the paper. <ul style="list-style-type: none"> * Select the Detect paper width check box again once printing is complete, and then click Send. <p>Windows</p> <p>The Custom Settings in the Maintenance sheet, clear the Detect paper width check box, and then click Send.</p> <p>Macintosh</p> <p>In the Canon IJ Printer Utility, select Custom Settings in the pop-up menu, clear the Detect paper width check box, and then click Send.</p> <p>The settings here are also applied under Direct Printing from a digital camera.</p>
<p>Twelve flashes: The paper is not loaded correctly in the Front Tray.</p>	<p>Press the RESUME/CANCEL button on the printer to clear the error, and then load the paper correctly in the Front Tray according to the procedure described in Loading Paper and try printing again.</p>
<p>Thirteen flashes: Ink level cannot be detected.</p>	<p>The remaining ink level cannot be correctly detected. (The lamp on the ink tank flashes.)</p> <p>Replace the ink tank and close the Top Cover.</p> <p>Printing with an ink tank that was once empty may damage the printer.</p> <p>If you want to continue printing in this condition, you need to release the function for detecting the remaining ink level. Press and hold the RESUME/CANCEL button for at least 5 seconds, and then release it.</p> <p>With this operation, releasing the function for detecting the remaining ink level is memorized. Please be advised that Canon shall not be liable for any printer malfunction or damage caused by refilled ink tanks.</p> <p>➔ Routine Maintenance</p> <p>Note</p> <ul style="list-style-type: none"> ▪ If the function for detecting the remaining ink level is disabled, the remaining ink level is not displayed correctly on the printer status monitor (Windows) and Canon IJ Printer Utility (Macintosh). <p>➔ Routine Maintenance</p>
<p>Fourteen flashes: Ink tank cannot be recognized.</p>	<p>The ink tank is not compatible with this printer. (The lamp on the ink tank is off.)</p> <p>Install an appropriate ink tank.</p> <p>➔ Routine Maintenance</p>
<p>Fifteen flashes: Ink tank cannot be recognized.</p>	<p>An Ink tank error has occurred. (The lamp on the ink tank is off.)</p> <p>Replace the ink tank.</p> <p>➔ Routine Maintenance</p>

Sixteen flashes:
Ink has run out.

Ink has run out. (The lamp on the ink tank flashes.)
Replace the ink tank and close the Top Cover.
Printing under the current condition may damage the printer.
If you want to continue printing in this condition, you need to release the function for detecting the remaining ink level.
Press and hold the **RESUME/CANCEL** button for at least 5 seconds, and then release it.
With this operation, releasing the function for detecting the remaining ink level is memorized. Please be advised that Canon shall not be liable for any malfunction or trouble which may be caused by continuation of printing under the ink out condition.

➔ [Routine Maintenance](#)

Note

- If the function for detecting the remaining ink level is disabled, the remaining ink level is not displayed correctly on the printer status monitor (Windows) and Canon IJ Printer Utility (Macintosh).

➔ [Routine Maintenance](#)

Nineteen flashes:
An unsupported USB hub is connected.

If a PictBridge compliant device is connected via a USB hub, remove the hub and connect it directly to the printer.

[Page top](#) ↕

Advanced Guide

[Advanced Guide](#) > [Troubleshooting](#) > [Power Lamp Flashes Green and Alarm Lamp Flashes Orange Alternately](#)

Power Lamp Flashes Green and Alarm Lamp Flashes Orange Alternately



A printer problem has occurred.

Disconnect the printer cable from the printer, turn the printer off, and then unplug the printer from the power supply.

Plug the printer back in and turn the printer back on.

If the problem is not resolved, contact the service center.

[Page top](#) ↕

Advanced Guide

Advanced Guide > Troubleshooting > Cannot Install the Printer Driver

Cannot Install the Printer Driver

- If the installation does not start even after the *Setup CD-ROM* is inserted into your computer's disc drive:



Start the installation following the procedure below.

1. Click Start then Computer.

In Windows XP, click Start then My Computer.

In Windows 2000, double-click the  My Computer icon on the desktop.

2. Double-click the  CD-ROM icon on the displayed window.

If the contents of the CD-ROM are displayed, double-click MSETUP4.EXE.



Double-click the  CD-ROM icon on your desktop to start installation.

Note

- If the CD-ROM icon is not displayed, try the followings:
 - Remove the CD-ROM from your computer, then insert it again.
 - Restart your computer.
- If the icon is still not displayed, try different discs and see if they are displayed. If other discs are displayed, there is a problem with the *Setup CD-ROM*. In this case, contact the service center.

- If you are unable to proceed beyond the Printer Connection screen:

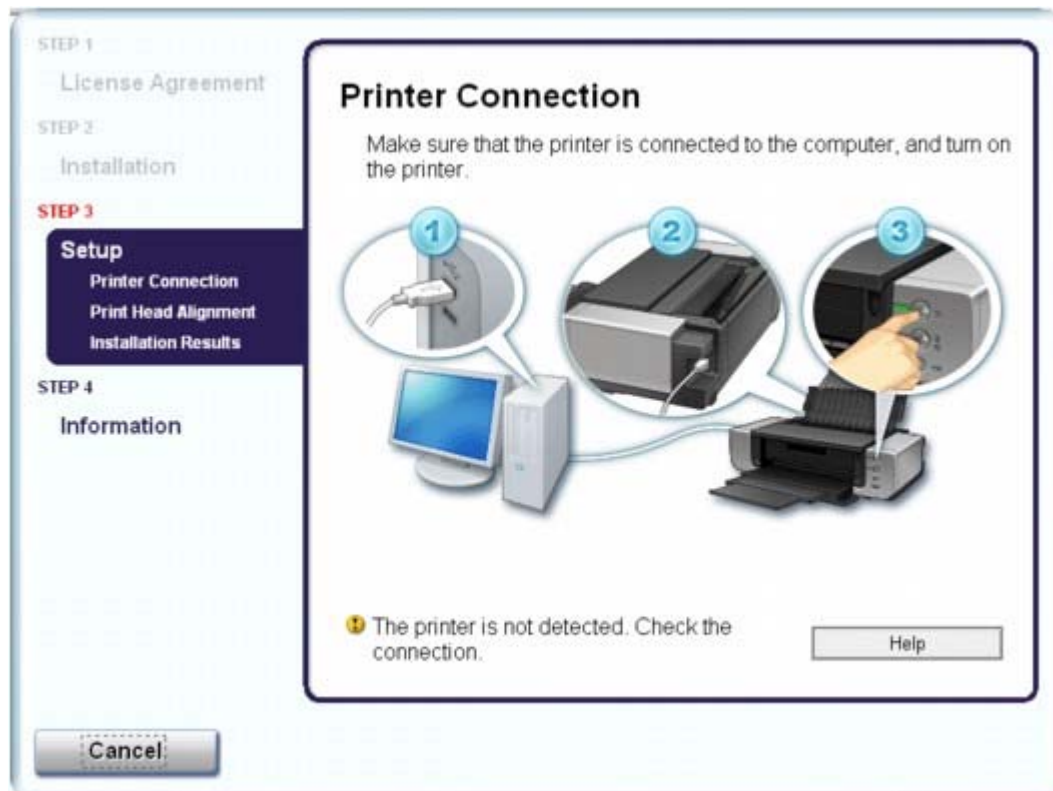

If you are unable to proceed beyond the Printer Connection screen, make sure that the USB cable is securely plugged into the USB port of the printer and is connected to the computer, and then follow the procedure below to reinstall the printer driver.

 **Note**

- In Windows Vista, The printer is not detected. Check the connection. may be displayed depending on the computer you use. In this case, wait for a while. If you still cannot proceed to the next step, follow the procedure below to reinstall the printer driver.
-

1. Click Cancel on the Printer Connection screen.
 2. Click Start Over on the Installation Failure screen.
 3. Click Back on the screen that appears next.
 4. Click Exit on the PIXMA XXX screen, then remove the CD-ROM.
 5. Turn the printer off.
 6. Restart the computer.
 7. Make sure that you have no application software running.
 8. Follow the procedure described in your setup manual to reinstall the printer driver.
- **In other cases:**

Follow the procedure described in your setup manual for proper installation.

If the driver was not installed correctly, uninstall the printer driver, restart your computer, then reinstall the driver.

➔ [Uninstalling the Printer Driver](#)

If you reinstall the printer driver, select Custom Install on the *Setup CD-ROM*.

 **Note**

- If the installer was forced to be terminated due to a Windows error, the system may be in an unstable condition and you may not be able to install the driver. Restart your computer before reinstalling.
-

Advanced Guide

Advanced Guide > Troubleshooting > Cannot Install the Application Program

Cannot Install the Application Program

Easy-PhotoPrint Pro Does Not Start up or Easy-PhotoPrint Pro Menu Does Not Appear

If the Easy-PhotoPrint Pro menu does not appear on Adobe Photoshop although you have installed Easy-PhotoPrint Pro, make sure that Adobe Photoshop is not running and install Adobe Photoshop Plug-In as described below.



1. Click Start, and select All Programs (or Programs), Canon Utilities, Easy-PhotoPrint Pro and then Photoshop Plug-In Installer.
2. Follow the on-screen instructions to install Adobe Photoshop Plug-In.



1. Select Applications from the Go menu, and double-click the Canon Utilities folder, the Easy-PhotoPrint Pro folder and then the Plug-In Installer icon.
2. Follow the on-screen instructions to install Adobe Photoshop Plug-In.

Note

- If you have never started up Adobe Photoshop before, Adobe Photoshop Plug-In cannot be installed.
-

Advanced Guide

Advanced Guide > Troubleshooting > Cannot Connect to Computer Properly

Cannot Connect to Computer Properly

Printing Speed Is Slow/Hi-Speed USB Connection Does Not Work/ "This device can perform faster" Message Is Displayed

If your system environment is not fully compatible with Hi-Speed USB, the printer will operate at a lower speed provided under USB 1.1. In this case, the printer operates properly but printing speed may slow down due to communication speed.

- **Check: Check the following to make sure that your system environment supports Hi-Speed USB connection.**
 - Does the USB port on your computer support Hi-Speed USB connection?
 - Do the USB cable, and the USB hub if you are using one, support Hi-Speed USB connection?
Be sure to use a certified Hi-Speed USB cable. We recommend that the cable is no longer than around 10 feet / 3 meters.
 - Does the operating system of your computer support Hi-Speed USB connection?
Obtain and install the latest update for your computer.
 - Does the Hi-Speed USB driver operate properly?
Obtain the latest version of the Hi-Speed USB driver compatible with your hardware and reinstall it on your computer.

Important

- For details on Hi-Speed USB of your system environment, contact the manufacturer of your computer, USB cable, or USB hub.

[Page top](#) 

Advanced Guide

Advanced Guide > Troubleshooting > Print Results Not Satisfactory

Print Results Not Satisfactory

If the print result is not satisfactory due to white streaks, misaligned lines, or uneven colors, confirm the paper and print quality settings first.

- **Check 1: Do the page size and media type settings match the size and type of the loaded paper?**

When these settings are incorrect, you cannot obtain a proper print result.

If you are printing a photograph or an illustration, incorrect paper type settings may reduce the quality of the printout color.

Also, if you print with an incorrect paper type setting, the printed surface may be scratched.

In borderless printing, uneven coloring may occur depending on the combination of the paper type setting and the loaded paper.

The method of confirming the paper and print quality settings differs depending on what you do with your printer.

To print from a PictBridge compliant device	Confirm by using your PictBridge compliant device. ➔ Printing Photographs Directly from a Compliant Device
To print from a computer	Confirm by using the printer driver. ➔ Printing with Easy Setup

- **Check 2: Make sure that the appropriate print quality is selected according to the media type and printing data referring to the table in**

Check 1.

Select a print quality option suitable for the paper and image for printing. If you notice blurs or uneven colors, increase the print quality setting and try printing again.



Note

- You cannot change the print quality setting from a PictBridge compliant device.

- **Check 3: If the problem is not resolved, there may be other causes.**

See also the sections below:

- ➔ [Cannot Print to End of Job](#)
- ➔ [No Printing Results/Printing Is Blurred/Colors Are Wrong/White Streaks](#)
- ➔ [Lines Are Misaligned](#)
- ➔ [Printed Paper Curls or Has Ink Blots](#)
- ➔ [Paper Is Smudged/Printed Surface Is Scratched](#)
- ➔ [Back of the Paper Is Smudged](#)
- ➔ [Colors Are Uneven or Streaked](#)

Advanced Guide

[Advanced Guide](#) > [Troubleshooting](#) > [Print Results Not Satisfactory](#) > [Cannot Print to End of Job](#)

Cannot Print to End of Job

- **Check 1: Is the size of the print data extremely large?**



Click Print Options on the Page Setup sheet. Then, select the Prevent loss of print data check box in the displayed dialog.

- **Check 2: Is the space of your computer's hard disk sufficient?**

Delete unnecessary files to free disk space.

[Page top](#) ↕

Advanced Guide

Advanced Guide > Troubleshooting > Print Results Not Satisfactory > No Printing Results/Printing Is Blurred/Colors Are Wrong/White Streaks

No Printing Results/Printing Is Blurred/Colors Are Wrong/White Streaks

❖ No Printing Results



❖ Printing Is Blurred

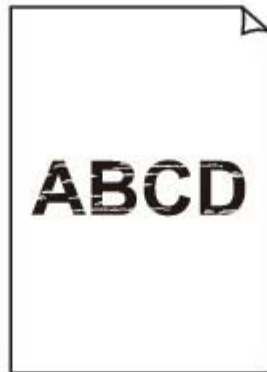

❖ Colors Are Wrong



❖ White Streaks

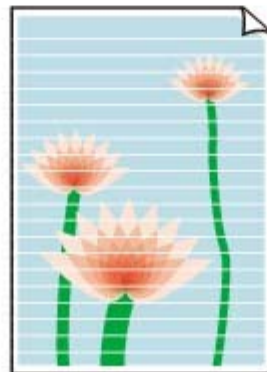

- **Check 1: Did you confirm the paper and print quality settings?**

➔ [Print Results Not Satisfactory](#)

- **Check 2: Check the status of ink tanks. Replace the ink tank if the ink**

has run out.

➔ [Routine Maintenance](#)

- **Check 3: Is the orange tape or protective film remaining?**

Make sure that all of the protective film is peeled off and the air hole is exposed, as illustrated in (A).

If the orange tape is left as in (B), pull the orange tape and remove it.

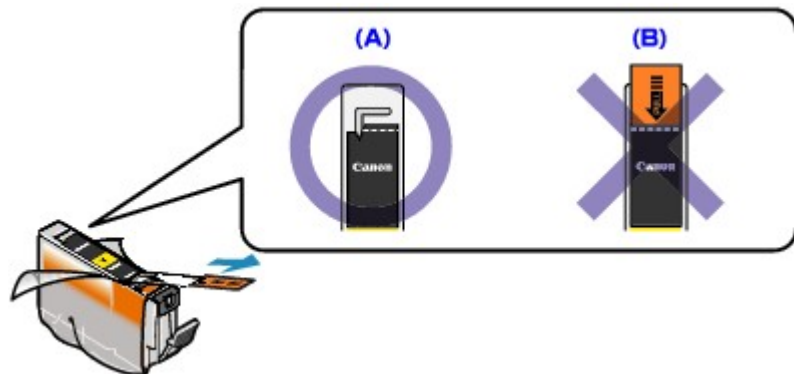

- **Check 4: Print the Nozzle Check Pattern and perform any necessary maintenance operations such as Print Head Cleaning.**

Print the Nozzle Check Pattern to determine whether the ink ejects properly from the print head nozzles.

Refer to [Routine Maintenance](#) for the Nozzle Check Pattern printing, Print Head Cleaning, and Print Head Deep Cleaning.

- If the Nozzle Check Pattern is not printed correctly:
 - Check to see if a particular color's ink tank is not empty.
 - If the Nozzle Check Pattern is not printed correctly though ink is sufficient, perform the Print Head Cleaning and try printing the Nozzle Check Pattern again.
- If the problem is not resolved after performing the Print Head Cleaning twice:
 - Perform the Print Head Deep Cleaning.
 - If the problem is not resolved after performing the Print Head Deep Cleaning, turn off the printer and perform another Print Head Deep Cleaning after 24 hours.
- If the problem is not resolved after performing the Print Head Deep Cleaning twice:
 - If Print Head Deep Cleaning does not resolve the problem, the Print Head may be damaged. Contact the service center.

- **Check 5: When using paper with one printable surface, make sure that the paper is loaded with the printable side facing up.**

Printing on the wrong side of such paper may cause unclear prints or prints with reduced quality.

Refer to the instruction manual supplied with the paper for detailed information on the printable side.



- **Check 6: Make sure that the input profile in the printer driver is set correctly.**

If printout color of photographs that are taken in Adobe RGB mode is not satisfactory, configure the input profile and then try printing again. It may improve the quality of printout color.

1. Open the printer properties dialog box.

➔ [Opening the Printer Properties Dialog Box \(Windows\)](#)



Click Here: [Printer Driver](#)

* Before clicking here to open the printer properties dialog box, quit the running application software.

2. On the Main sheet, select Manual for Color/Intensity, and then click Set.

3. On the Matching sheet, select ICM for Color Correction.

4. Select Adobe RGB (1998) for Input Profile.

If Adobe RGB (1998) is not displayed, select Custom Install on the *Setup CD-ROM*, then install the Adobe RGB (1998).

[Page top ↕](#)

Advanced Guide

Advanced Guide > Troubleshooting > Print Results Not Satisfactory > Lines Are Misaligned

Lines Are Misaligned



- **Check 1: Did you confirm the paper and print quality settings?**

➔ [Print Results Not Satisfactory](#)

- **Check 2: Perform Print Head Alignment.**

If you did not align the Print Head after installation, straight lines may be printed misaligned. Be sure to align the Print Head after you install it.

➔ [Routine Maintenance](#)

Note

- If the problem is not resolved after performing the Print Head Alignment, perform Print Head Alignment manually referring to [Manual Print Head Alignment](#).

Windows

- **Check 3: Is the size of the print data extremely large?**

Click Print Options on the Page Setup sheet. Then, select the Prevent loss of print data check box in the displayed dialog.

- **Check 4: Is the Page Layout Printing performed or the Binding margin function used?**

When the Page Layout Printing or Binding margin function is being used, thin lines may not be printed. Try thickening the lines in the document.

[Page top](#) ↕

Advanced Guide

Advanced Guide > Troubleshooting > Print Results Not Satisfactory > Printed Paper Curls or Has Ink Blots

Printed Paper Curls or Has Ink Blots

Printed Paper Curls



Printed Paper Has Ink Blots



- **Check 1: Did you confirm the paper and print quality settings?**

➔ [Print Results Not Satisfactory](#)

- **Check 2: If the intensity is set high, reduce the Intensity setting in the printer driver and try printing again.**

If you are using plain paper to print images with high intensity, the paper may absorb too much ink and become wavy, causing paper abrasion.

Confirm the intensity using the printer driver.

➔ [Adjusting Intensity](#)

- **Check 3: Is Photo Paper used for printing photographs?**

It is recommended that you use photo paper to print photos or pictures in deep color that have high color saturation.

➔ [Loading Paper](#)

[Page top](#) ↕

Advanced Guide

Advanced Guide > Troubleshooting > Print Results Not Satisfactory > Paper Is Smudged/Printed Surface Is Scratched

Paper Is Smudged/Printed Surface Is Scratched

▶ Paper Is Smudged

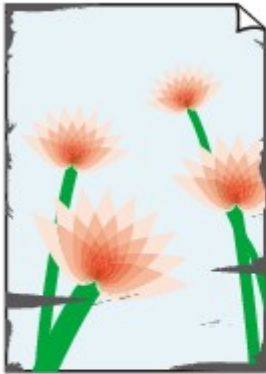

The Edges of Paper Are Smudged

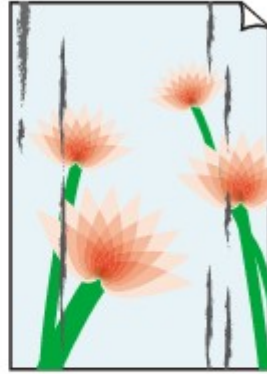

Printed Surface Is Smudged



▶ Printed Surface Is Scratched

- **Check 1: Did you confirm the paper and print quality settings?**

➔ [Print Results Not Satisfactory](#)

- **Check 2: Is the appropriate type of paper used? Check the followings:**

- Check to see if the paper you are printing on is suitable for your printing purpose.

➔ [Loading Paper](#)

- When performing Borderless Printing, make sure that the paper you are using is suitable for Borderless Printing.

If the paper you are using is not suitable for Borderless Printing, the print quality may be reduced at the top and bottom edges of the paper.

➔ [Printing Area](#)

- **Check 3: Load the paper after correcting its curl.**

- **For Plain Paper**

Turn the paper over and reload it to print on the other side.

Leaving the paper loaded on the Rear Tray for a long time may cause the paper to curl. In this case, load the paper with the other side facing up. It may resolve the problem.

We recommend putting unused paper back into the package and keeping it on a level surface.

- **For Other Paper**

1. With the printing side (A) facing up, cover the paper with a fresh sheet of plain paper to avoid staining or scratching the surface.
2. Roll up the paper in the opposite direction to the paper curl as shown below.

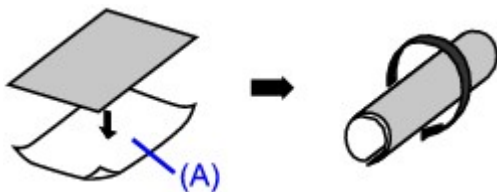

3. Check to see that the paper curl is within approximately 0.08 to 0.2 inches /2 to 5 mm (B) in height.

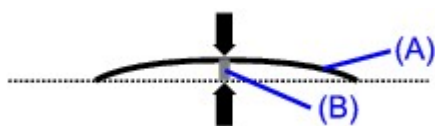

We recommend printing curl-corrected paper one sheet at a time.

Note

■ For Paper That Curls Inward When It Is Printed

Depending on the media type, the paper may be smudged or may not be fed properly even if it is not curled inward. In such cases, follow the procedure described below to curl the paper outward before printing. This may improve the print result.

1. With the printing side (A) facing up, cover the paper with a fresh sheet of plain paper to avoid staining or scratching the surface.
2. Roll up the paper as shown below.

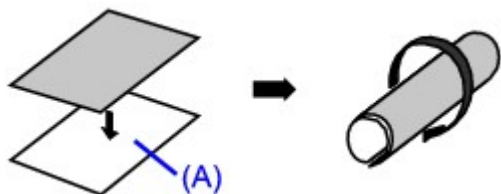

3. Check to see that the paper curl is within approximately 0.08 to 0.2 inches / 2 to 5 mm (B) in height.

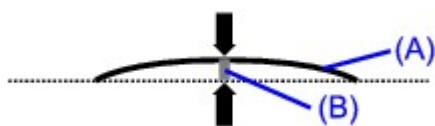

We recommend printing paper that has been curled outward one sheet at a time.

• **Check 4: If you are printing on thick paper, select the Prevent paper abrasion setting.**

Selecting the Prevent paper abrasion setting will widen the clearance between the Print Head and the loaded paper. If you notice abrasion even with the media type set correctly to match the loaded paper, set the printer to prevent paper abrasion by using the printer driver.

* Deactivate the Prevent paper abrasion setting once printing is complete. If not, this setting remains enabled for all subsequent print jobs.

Windows

Open the printer properties dialog box, and in Custom Settings in the Maintenance sheet, select the Prevent paper abrasion check box, and then click Send.

To open the printer properties dialog box, see [Opening the Printer Properties Dialog Box \(Windows\)](#).

Macintosh

In the Canon IJ Printer Utility, select Custom Settings in the pop-up menu, select the Prevent paper abrasion check box, and then click Send.

To open the Canon IJ Printer Utility, see [Opening the Canon IJ Printer Utility \(Macintosh\)](#).

• **Check 5: If you are printing on board paper or especially thick paper (from 0.6 mm / 23 mil to 1.2 mm / 47 mil), select Board Paper from Media Type in the printer driver.**

The printed surface may be scratched or a malfunction may occur if Media Type is set to anything other than Board Paper. Paper that is thicker than 1.2 mm / 47 mil cannot be used.

• **Check 6: If the intensity is set high, reduce the Intensity setting in the printer driver and try printing again.**

If you are using plain paper to print images with high intensity, the paper may absorb too much ink and become wavy, causing paper abrasion.

Reduce the Intensity setting in the printer driver and try printing again.



1. Open the printer properties dialog box.

➔ [Opening the Printer Properties Dialog Box \(Windows\)](#)



Click Here: [Printer Driver](#)

* Before clicking here to open the printer properties dialog box, quit the running application software.

2. On the Main sheet, select Manual for Color/Intensity, and then click Set.

3. Drag the Intensity slide bar on the Color Adjustment sheet to adjust the intensity.



1. Open the Print dialog box.

➔ [Opening the Page Setup and Print Dialog Box \(Macintosh\)](#)

2. Select Color Options in the pop-up menu.

3. Drag the Intensity slide bar to set the intensity.

• Check 7: Is printing performed beyond the recommended printing area?

If you are printing beyond the recommended printing area of your printing paper, the lower edge of the paper may become stained with ink.

Resize your original document in your application software.

➔ [Printing Area](#)

• Check 8: Is the Paper Feed Roller dirty?

Clean the Paper Feed Roller.

➔ [Routine Maintenance](#)



Note

- Cleaning the Paper Feed Roller will wear the roller, so perform this procedure only when necessary.

• Check 9: Is inside of the printer dirty?

When performing duplex printing, the inside of the printer may become stained with ink, causing the printout to become smudged.

Perform the Bottom Plate Cleaning to clean the inside of the printer.

➔ [Cleaning Inside the Printer](#)



Note

- To prevent the inside of the printer from stains, set the paper size correctly.

• Check 10: Set Ink Drying Wait Time longer.

Doing so gives the printed surface enough time to dry so that paper smudged and scratched are prevented.



1. Make sure that the printer is turned on.

2. Open the printer properties dialog box.

➔ [Opening the Printer Properties Dialog Box \(Windows\)](#)

3. Click the Maintenance tab and then Custom Settings.
4. Drag the Ink Drying Wait Time slide bar to set the wait time, and then click Send.
5. Confirm the message and click OK.



1. Make sure that the printer is turned on.
 2. Open the Canon IJ Printer Utility.
 - ➔ [Opening the Canon IJ Printer Utility \(Macintosh\)](#)
 3. Select Custom Settings in the pop-up menu.
 4. Drag the Ink Drying Wait Time slide bar to set the wait time, and then click Send.
 5. Confirm the message and click OK.
- **Check 11: Is the paper scratched by other loaded paper?**

Depending on the media type, the paper may be scratched by other loaded paper when feeding from the Rear Tray. In this case, load one sheet at a time.

Advanced Guide

Advanced Guide > Troubleshooting > Print Results Not Satisfactory > Back of the Paper Is Smudged

Back of the Paper Is Smudged

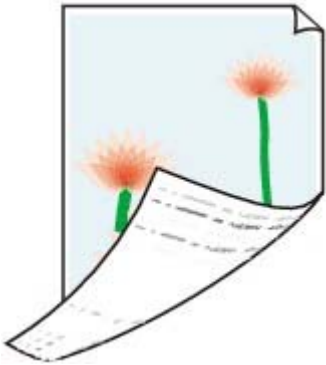

- **Check 1: Did you confirm the paper and print quality settings?**
 - ➔ [Print Results Not Satisfactory](#)
- **Check 2: Perform the Bottom Plate Cleaning to clean the inside of the printer.**
 - ➔ [Cleaning Inside the Printer](#)

Note

- When performing duplex printing or too much printing, the inside may become stained with ink.

[Page top](#) ↕

Advanced Guide

Advanced Guide > Troubleshooting > Print Results Not Satisfactory > Colors Are Uneven or Streaked

Colors Are Uneven or Streaked

▣ Colors Are Uneven



▣ Colors Are Streaked



- **Check 1: Did you confirm the paper and print quality settings?**

➔ [Print Results Not Satisfactory](#)

- **Check 2: Print the Nozzle Check Pattern and perform any necessary maintenance operations such as Print Head Cleaning.**

Print the Nozzle Check Pattern to determine whether the ink ejects properly from the print head nozzles.

Refer to [Routine Maintenance](#) for the Nozzle Check Pattern printing, Print Head Cleaning, and Print Head Deep Cleaning.

- If the Nozzle Check Pattern is not printed correctly:
Check to see if a particular color's ink tank is not empty.
If the Nozzle Check Pattern is not printed correctly though ink is sufficient, perform the Print Head Cleaning and try printing the Nozzle Check Pattern again.
- If the problem is not resolved after performing the Print Head Cleaning twice:
Perform the Print Head Deep Cleaning.
If the problem is not resolved after performing the Print Head Deep Cleaning, turn off the printer and perform another Print Head Deep Cleaning after 24 hours.
- If the problem is not resolved after performing the Print Head Deep Cleaning twice:
If Print Head Deep Cleaning does not resolve the problem, the Print Head may be damaged.
Contact the service center.

- **Check 3: Perform Print Head Alignment.**

➔ [Routine Maintenance](#)

Note

- If the problem is not resolved after performing the Print Head Alignment, perform Print Head

Alignment manually referring to [Manual Print Head Alignment](#).

- **Check 4: When printing in grayscale, follow the procedure below.**

When printing in grayscale, depending on an image, the printing troubles may occur on the top and/or bottom edges of the paper such as uneven coloration or white streaks. In this case, we recommend printing with the top and bottom margins in the print direction of the paper set to more than 45 mm / 1.77 inches using the Easy-PhotoPrint Pro provided on the *Setup CD-ROM* or your page layout software.

To set margins using the Easy-PhotoPrint Pro, print following the procedure described in "Printing Grayscale Photos from Easy-PhotoPrint Pro" in "Printing in Grayscale" in the *Digital Photo Printing Guide* on-screen manual.

If you want to print with no margin, convert the image to grayscale using an image-editing software or the like, then print it without the Grayscale Printing setting in the printer driver. To do so, in Windows, clear the Grayscale Printing check box on the Main sheet, then print. In Macintosh, select Quality & Media from the pop-up menu in the Print dialog box, and clear the Grayscale Printing check box, then print. If printing using the Easy-PhotoPrint Pro provided on the *Setup CD-ROM* after converting to grayscale, clear the Grayscale Photo check box. The gray balance of the image printed after grayscale conversion may seem different compared with the one printed with the Grayscale Printing setting in the printer driver or the Grayscale Photo setting in the Easy-PhotoPrint Pro.

[Page top](#) ↕

Advanced Guide

Advanced Guide > Troubleshooting > Printing Does Not Start

Printing Does Not Start

- **Check 1: Make sure that the power plug is securely plugged in, then turn the printer on.**

While the **Power** lamp is flashing green, the printer is initializing. Wait until the **Power** lamp stops flashing and remains lit green.

Note

- When printing large data such as a photo or graphics, it may take longer to start printing. While the **Power** lamp is flashing green, the computer is processing data and sending it to the printer. Wait until printing starts.

- **Check 2: Check the status of ink tanks. Replace the ink tank if ink has run out.**

- **Check 3: Open the Top Cover and check to see if the ink lamps are flashing red.**

If there is still sufficient ink but its ink lamp is flashing red, an ink tank may not be installed in a right position.

➔ [Routine Maintenance](#)

- **Check 4: Open the Top Cover and make sure that the ink lamps light up red.**

If the ink lamp is not lit, press the  mark on the ink tank until it clicks into place.

- **Check 5: Make sure that the USB cable is securely plugged in to the printer and the computer, then check the followings:**

- If you are using a relay device such as a USB hub, disconnect it, connect the printer directly to the computer, and try printing again. If printing starts normally, there is a problem with the relay device. Consult the reseller of the relay device for details.
- There could also be a problem with the USB cable. Replace the USB cable and try printing again.

- **Check 6: Restart your computer if you are printing from the computer.**

If there are any unnecessary print jobs, delete them.

➔ [Deleting the Undesired Print Job](#)

- **Check 7: Make sure that the Inner Cover is closed.**

If the Inner Cover is opened, close the Inner Cover and press the **RESUME/CANCEL** button on the printer.

- **Check 8: Does the Page Size setting match the size of the paper loaded in the printer?**

Press the **RESUME/CANCEL** button on the printer to clear the error. Then check the Page Size setting in the Page Setup sheet (Windows) or the Page Setup dialog box (Macintosh) in the printer driver and load paper that is the same size as the setting and try printing again.

If printing does not start even when the paper loaded in the printer is the same as the setting, set the printer driver not to detect the width of the paper.

* Select the Detect paper width check box again once printing is complete, and then click Send.



The Custom Settings in the Maintenance sheet, clear the Detect paper width check box, and then click Send.



In the Canon IJ Printer Utility, select Custom Settings in the pop-up menu, clear the Detect paper width check box, and then click Send.

The settings here are also applied under Direct Printing from a digital camera.

- **Check 9: Are the Media Type and the Page Size settings of the printer driver correct?**

When using Art Paper or non Canon genuine specialty paper, be sure to select the type of each media from Media Type and a paper size which says "Art XX (Margin 35)" from Paper size.

Confirm the settings following the procedure below, and try printing again.

1. If the page size you want to use is not displayed, open the File menu of the application and select Print. Then make sure that the name of your printer is selected.
2. Make sure that the paper selected for Media Type in the Main sheet (Windows) or the Print dialog box (Macintosh) in the printer driver matches the paper loaded in the printer.
3. Make sure that the Page Size setting in the Page Setup sheet (Windows) or the Paper size setting in the Page Setup dialog box (Macintosh) in the printer driver is the same as the size set in step 1.

- **Check 10: Make sure that your printer's name is selected in the Print dialog box.**

The printer will not print properly if you are using a driver for a different printer.

In Windows, make sure that your printer's name is selected in the Print dialog box.

In Macintosh, make sure that your printer's name is selected in Printer in the Print dialog box.

 **Note**

- To make the printer the one selected by default, select Set as Default Printer (Windows), Default Printer or Make Default (Macintosh).



- **Check 11: Configure the printer port appropriately.**

Configure "USBnnn" (where "n" is a number) as the printer port.

1. Log on as a user account with administrator privilege.
2. Click Control Panel, then Printer under Hardware and Sound.
In Windows XP, click Control Panel, Printers and Other Hardware, then Printers and Faxes.
In Windows 2000, click Control Panel then Printers.
3. Right-click the Canon XXX icon, then select Properties.
4. Click the Ports tab to confirm the port settings.
Make sure that a port named USBnnn (where "n" is a number) with Canon XXX appearing in the Printer column is selected for Print to the following port(s).
If the setting is incorrect, reinstall the printer driver or change the printer port to the correct one.

Advanced Guide

Advanced Guide > Troubleshooting > Printing Stops Before It Is Completed

Printing Stops Before It Is Completed

- **Check 1: Is the Inner Cover opened while printing on paper?**

Close the Inner Cover and press the **RESUME/CANCEL** button on the printer.

A page of print data being sent at the time of the error will be erased, so print that page again.

- **Check 2: Has the printer been printing continuously for a long period?**

If the printer has been printing continuously for a long time, the Print Head may overheat. To protect the Print Head, the printer may stop printing at a line break for a period of time and then resume printing.

In this case, interrupt your print session at a convenient time and turn the printer off for at least 15 minutes.

Additionally, if the printer has been printing graphics or photos with intense colors continuously over a period of time, the printer may stop printing to protect the Print Head. In this case, printing will not resume automatically. Turn the printer off for at least 15 minutes.

Caution

- The Print Head and the surrounding area can become extremely hot inside the printer. Never touch the Print Head or nearby components.

- **Check 3: Is the paper loaded?**

Make sure that paper is loaded in the Rear Tray or Front Tray.

If the printer has run out of paper, load paper.

- **Check 4: Do the printing documents have lots of photographs or illustrations?**

Printing large data such as photos or graphics takes time for the printer and the computer to process, during which the printer may appear to have stopped operating.

In addition, when printing data that uses a large amount of ink continuously on plain paper, the printer may pause temporarily. In either case, wait until the process is complete.

Note

- If you are printing a document with a large printing area or printing multiple copies of a document, printing may pause to allow the ink to dry.

Advanced Guide

Advanced Guide > Troubleshooting > Printer Moves But Ink Is Not Ejected

Printer Moves But Ink Is Not Ejected

• Check 1: Are the Print Head nozzles clogged?

Print the Nozzle Check Pattern to determine whether the ink ejects properly from the print head nozzles.

Refer to [Routine Maintenance](#) for the Nozzle Check Pattern printing, Print Head Cleaning, and Print Head Deep Cleaning.

- If the Nozzle Check Pattern is not printed correctly:
Check to see if a particular color's ink tank is not empty.
If the Nozzle Check Pattern is not printed correctly though ink is sufficient, perform the Print Head Cleaning and try printing the Nozzle Check Pattern again.
- If the problem is not resolved after performing the Print Head Cleaning twice:
Perform the Print Head Deep Cleaning.
If the problem is not resolved after performing the Print Head Deep Cleaning, turn off the printer and perform another Print Head Deep Cleaning after 24 hours.
- If the problem is not resolved after performing the Print Head Deep Cleaning twice:
If Print Head Deep Cleaning does not resolve the problem, the Print Head may be damaged.
Contact the service center.

• Check 2: Has the ink run out?

Open the Top Cover, then check the status of ink lamp.

➔ [Routine Maintenance](#)

• Check 3: Is the orange tape or protective film remaining?

Make sure that all of the protective film is peeled off and the air hole is exposed, as illustrated in (A).

If the orange tape is left as in (B), pull the orange tape and remove it.

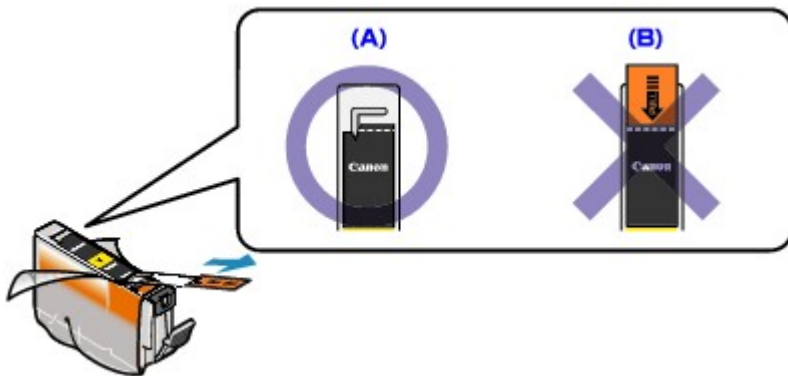

Advanced Guide

Advanced Guide > Troubleshooting > Printing Speed Is Not as Fast as Expected

Printing Speed Is Not as Fast as Expected

• Check 1: Is printing performed in Quiet Mode?

Print speed is reduced if you specified to print in Quiet Mode in the printer driver. For faster printing, do not print in Quiet Mode.

➔ [Reducing the Printer Noise](#)

• Check 2: Is the print quality set too high?

Increase the printing speed setting in the printer driver. Setting to prioritize speed makes printing faster.



1. Open the printer properties dialog box.

➔ [Opening the Printer Properties Dialog Box \(Windows\)](#)



Click Here: [Printer Driver](#)

* Before clicking here to open the printer properties dialog box, quit the running application software.

2. On the Main sheet, select Fast for the Print Quality setting.

Depending on the media type, the Fast option may not be available.



1. Open the Print dialog box.

➔ [Opening the Page Setup and Print Dialog Box \(Macintosh\)](#)

2. Select Quality & Media in the pop-up menu and then select Fast for the Print Quality setting.

Depending on the media type, the Fast option may not be available.



Note

- Printing speed may not improve noticeably by following the instructions above, depending on your system environment.

Advanced Guide

Advanced Guide > Troubleshooting > Print Head Holder Does Not Move to the Position for Replacing

Print Head Holder Does Not Move to the Position for Replacing

• Check 1: Is the Power lamp off?

Check if the **Power** lamp is lit green.

The Print Head Holder will not move unless the power is on. If the **Power** lamp is off, close the Top Cover and turn the printer on.

While the **Power** lamp is flashing green, the printer is initializing. Wait until the **Power** lamp stops flashing and remains lit green, and then open the Top Cover again.

• Check 2: Is the Alarm lamp flashing?

Close the Top Cover, confirm the number of times the **Alarm** lamp is flashing, take the appropriate action to resolve the error, and then reopen it. For details on how to resolve the error, see [Alarm Lamp Flashes Orange](#).

• Check 3: Has the Top Cover been left open for 10 minutes or longer?

If the Top Cover is left open for more than 10 minutes, the Print Head Holder moves to the right to prevent the Print Head from drying out. Close and reopen the Top Cover to return the Print Head Holder to the center.

• Check 4: If the printer is preparing to feed paper from the Front Tray (when the Front Feed button is flashing quickly), close the Top Cover and press the Front Feed button. Wait until the Front Feed button stops flashing and stays lit, and then open the Top Cover.

If the printer is preparing to feed paper from the Front Tray (when the **Front Feed** button is flashing quickly), the Print Head Holder may not move to the center. In this case, close the Top Cover, press the **Front Feed** button and wait until the **Front Feed** button stops flashing and stays lit. Reopen the Top Cover to move the Print Head Holder to the center.

To continue printing from the Front Tray after replacing the ink tank, refer to [Loading Paper](#) and start printing again.

• Check 5: Has the printer been printing continuously for a long period?

Close the Top Cover, wait a while, then reopen it.

If the printer has been printing continuously for a long time, the Print Head Holder may not move to the center since the Print Head may overheat.

Note

- Opening the Top Cover while printing moves the Print Head Holder to the right. Close the Top Cover, and reopen it after printing finishes.

Advanced Guide

Advanced Guide > Troubleshooting > Paper Does Not Feed Properly

Paper Does Not Feed Properly

- **Check 1: Make sure of the following when you load paper.**

- When loading two or more sheets of paper, align the edges of the sheets before loading.
- When loading two or more sheets of paper, make sure that the paper stack does not exceed the paper load limit.
However, proper feeding of paper may not be possible at this maximum capacity depending on the type of paper or environmental conditions (either very high or low temperature and humidity). In such cases, reduce the sheets of paper you load at a time to less than half of the paper load limit.
- Always load the paper in portrait orientation, either in the Rear Tray or the Front Tray, regardless of the printing orientation.
- When you load the paper on the Rear Tray, load the paper with the print side facing UP. Align the paper stack against the right side of the Rear Tray and slide the Paper Guide so that it just touches the left edge of the stack.
- When you load the paper on the Front Tray, load one sheet at a time with the print side facing UP. Insert the paper straight into the Front Tray so that the front edge of the paper aligns with the  mark on the Front Tray, then align the right edge of the paper against the right side of the Front Tray.

➔ [Loading Paper](#)

- **Check 2: Check to see if the paper you are printing on is not too thick or curled.**

➔ [Loading Paper](#)

- **Check 3: If you are using art paper that is not produced by Canon, make sure that the paper is 200 gsm (53 lb) or less.**

Printing cannot be done from the Rear Tray if the paper is too heavy. Check the paper's package for information on its weight. If it is more than 200 gsm (53 lb), load it in the Front Tray.

- **Check 4: Make sure of the following when you load envelopes.**

When printing on envelopes, refer to [Loading Paper](#), and prepare the envelopes before printing. Once you have prepared the envelopes, load them in portrait orientation. If the envelopes are placed in landscape orientation, they will not feed properly.

- **Check 5: Remove the foreign object in the Front Tray.**

- **Check 6: Make sure that there are not any foreign objects in the Rear Tray.**



If the paper tears in the Rear Tray, see [Paper Jams](#) to remove it.

If there are any foreign objects in the Rear Tray, be sure to turn off the printer, unplug it from the power supply, then remove the foreign object.



- **Check 7: Make sure that the Inner Cover is closed completely.**

Paper does not feed properly if the Inner Cover is even slightly open.

➔ [Overview of the Printer](#)

- **Check 8: Clean the Paper Feed Roller.**

➔ [Routine Maintenance](#)

Note

- Cleaning the Paper Feed Roller will wear the roller, so perform this procedure only when necessary.

Advanced Guide

Advanced Guide > Troubleshooting > Paper Does Not Feed from the Paper Source Specified in the Printer Driver

Paper Does Not Feed from the Paper Source Specified in the Printer Driver



- **Check: Is the paper source setting inconsistent between the application program and the printer driver?**

Change the application software setting corresponding to the printer driver setting, or click the Print Options on the Page Setup sheet in the printer driver and select Disable the paper source setting of the application software on the Print Options screen.

When the paper source setting is inconsistent between an application program and the printer driver, the application software setting takes precedence.

[Page top](#) ↕

Advanced Guide

Advanced Guide > Troubleshooting > Paper Jams

Paper Jams

Note

- If you need to turn off the printer to remove jammed paper during printing, press the **RESUME/CANCEL** button to cancel print jobs before turning off the printer.

If paper is jammed in the Rear Tray, the Front Tray, or the Front Feed Support:

Remove the paper following the procedure below.

1. Slowly pull the paper out, either from the Rear Tray or from the Paper Output Slot, whichever is easier.

Feeding from the Rear Tray:

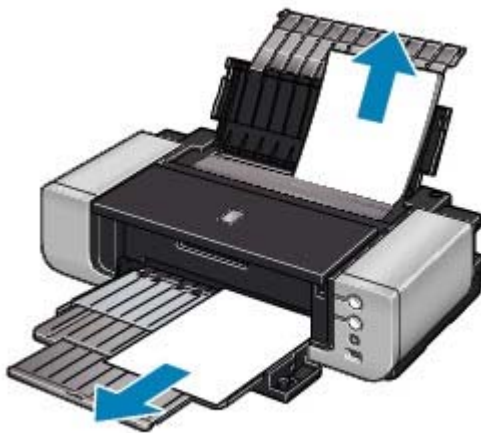

Feeding from the Front Tray:

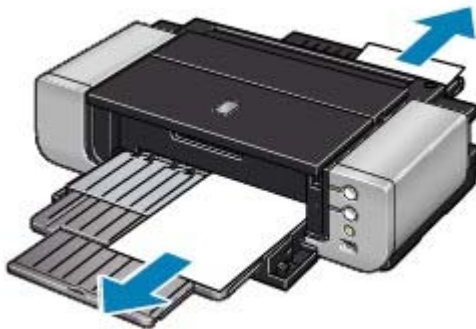

Note

- If the paper tears and a piece remains inside the printer, open the Top Cover and remove it.
Be careful not to touch the components inside the printer.
After removing all paper, close the Top Cover, turn the printer off, and turn it back on.
- If you cannot pull the paper out, turn the printer off and turn it back on. The paper may be ejected automatically.

2. Reload the paper, and press the **RESUME/CANCEL** button on the printer.

Set the Paper Guide correctly when printing from the Rear Tray. The paper may not feed properly if the Paper Guide is not set correctly.

If you turned off the printer in step 1, all print jobs in the queue are canceled. Reprint if necessary.

Note

- When reloading the paper, confirm that you are using the correct paper and are loading it correctly.
 - ➔ **Loading Paper**
 - A5 sized paper is suited to printing documents consisting mainly of text. We do not recommend using such paper to print documents with photos or graphics, since the printout may curl and cause paper exit jams.
-

If you cannot remove the paper or the paper tears inside the printer, or if the paper jam error continues after removing the paper, contact the service center.

In other cases:

Make sure of the following:

- **Check 1: Are there any foreign objects around the Paper Output Slot?**
- **Check 2: Are there any foreign objects in the Rear Tray?**



If there are any foreign objects in the Rear Tray, be sure to turn off the printer, unplug it from the power supply, then remove the foreign object.

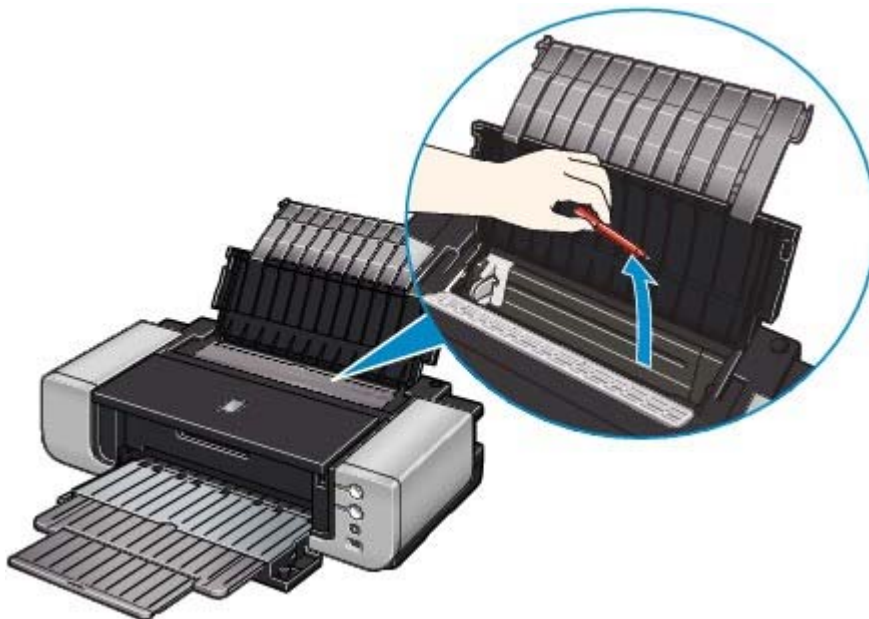

- **Check 3: Is the paper curled?**
 - ➔ **Check 3: Load the paper after correcting its curl.**

Advanced Guide

Advanced Guide > Troubleshooting > Message Appears on the Computer Screen

Message Appears on the Computer Screen

- ➔ Error Number: B200 A printer error has occurred. Turn the printer off and unplug the power cord of the printer from the power supply. Then contact the service center. Is Displayed
- ➔ Error Number: **** A printer error has occurred. Turn the printer off and then on again. If this doesn't clear the error, see the user's guide for more detail. Is Displayed
- ➔ Error Regarding the Rear Tray or Front Tray Is Displayed
- ➔ Error Regarding the Width of Paper Is Displayed
- ➔ Error Regarding Automatic Print Head Alignment Is Displayed
- ➔  Writing Error/Output Error/Communication Error
- ➔  Error Number: 92 Is Displayed
- ➔  Error Number: 93 Is Displayed
- ➔  Error Number: 300 Is Displayed
- ➔  Error Number: 1281 Is Displayed
- ➔  Error Number: 1283 Is Displayed
- ➔  Error Number: 1284 Is Displayed
- ➔  Error Number: 1320 Is Displayed
- ➔  Error Number: 1321 Is Displayed
- ➔  Error Number: 1700 Is Displayed
- ➔  Ink Info Number: 1600 Is Displayed
- ➔  Ink Info Number: 1683 Is Displayed
- ➔  Ink Info Number: 1688 Is Displayed
- ➔  Error Number: 1851 Is Displayed
- ➔  Error Number: 1856 Is Displayed
- ➔  Error Number: 2001 Is Displayed
- ➔  Error Number: 2002 Is Displayed
- ➔  Error Number: 2500 Is Displayed
- ➔  Other Error Messages
- ➔  The Inkjet Printer/Scanner/Fax Extended Survey Program Screen Is Displayed
- ➔  The Inkjet Printer/Scanner/Fax Extended Survey Program Icon Appears

Error Number: B200 A printer error has occurred. Turn the printer off and unplug the power cord of the printer from the power supply. Then contact the service center. Is Displayed

Turn off the printer, and unplug the power cord of the printer from the power supply.
Contact the service center.

Error Number: ** A printer error has occurred. Turn the printer off and then on again. If this doesn't clear the error, see the user's guide for more detail. Is Displayed**

"****" is displayed in the alphanumeric character and depends on the error occurred.

- **5100 or 5110 Is Displayed**

Confirm the movement of the Print Head Holder blocked.

Cancel printing from your computer and turn off the printer. Then clear the jammed paper or

protective material that is preventing the Print Head Holder from moving, and turn on the printer again.

Important

- Be careful not to touch the components inside the printer. The printer may not print out properly if you touch it.
- If the problem is not resolved, contact the service center.

- **Four-digit alphanumeric and "Printer error has occurred." Is displayed.**

Turn off the printer, and unplug the power cord of the printer from the power supply.

Plug the printer back in and turn the printer back on.

If the problem is not resolved, contact the service center.

Error Regarding the Rear Tray or Front Tray Is Displayed

- **Check 1: Is the printer ready to feed paper from the Front Tray?**

Load the paper correctly in the Front Tray and press the **RESUME/CANCEL** button on the printer.

Refer to [Loading Paper](#) for details about how to load the paper correctly in the Front Tray.

- **Check 2: Is the paper size that cannot feed from the Rear Tray selected in the printer driver?**

Select the paper source correctly and try printing again.



Click Cancel Printing, in the dialog box that is displayed. Then select Front Tray from Paper Source on the Main sheet in the printer driver. Load the paper in the Front Tray and try printing again.



Click Delete Job in the dialog box that is displayed. Select Quality & Media from the pop-up menu in the Print dialog box and select Front Tray from Paper Source. Then load the paper in the Front Tray and try printing again.

- **Check 3: Is the paper size that cannot feed from the Front Tray selected in the printer driver?**

Select the paper source correctly and try printing again.



Click Cancel Printing, in the dialog box that is displayed. Then select Rear Tray from Paper Source on the Main sheet in the printer driver. Load the paper in the Rear Tray and try printing again.



Click Delete Job in the dialog box that is displayed. Select Quality & Media from the pop-up menu in the Print dialog box and select Rear Tray from Paper Source. Then load the paper in the Rear Tray and try printing again.

- **Check 4: Is the paper loaded correctly in the Front Tray?**

Press the **RESUME/CANCEL** button on the printer to clear the error, and then load the paper correctly in the Front Tray according to the procedure described in [Loading Paper](#) and try printing again.

- **Check 5: Is the Front Tray up when printing from the Rear Tray starts?**

Return the Front Tray to its normal printing position, make sure that paper is loaded in the Rear Tray, then press the **RESUME/CANCEL** button on the printer to resume printing. Refer to [Loading Paper](#) for details about how to return the Front Tray to its normal printing position.

- **Check 6: If the Front Tray is pulled up while printing from the Rear Tray, return the Front Tray to its normal printing position, then press the RESUME/CANCEL button on the printer and try printing again.**

Refer to [Loading Paper](#) for details about how to return the Front Tray to its normal printing position.

Do not move the Front Tray during printing.

- **Check 7: If the Front Tray is pulled down while printing from the Front Tray, return the Front Tray to the Front Paper Feeding Position, then press the RESUME/CANCEL button on the printer and try printing again.**

Refer to [Loading Paper](#) for details about how to return the Front Tray to its normal printing position.

Do not move the Front Tray during printing.

Error Regarding the Width of Paper Is Displayed

- **Check: Make sure that the Page Size setting matches the size of the paper loaded in the printer.**

Press the **RESUME/CANCEL** button on the printer to clear the error. Then check the Page Size setting in the Page Setup sheet (Windows) or the Page Setup dialog box (Macintosh) in the printer driver and load paper that is the same size as the setting and try printing again.

If this message appears even when the paper loaded in the printer is the same as the setting, set the printer driver not to detect the width of the paper.

* Select the Detect paper width check box again once printing is complete, and then click Send.



The Custom Settings in the Maintenance sheet, clear the Detect paper width check box, and then click Send.



In the Canon IJ Printer Utility, select Custom Settings in the pop-up menu, clear the Detect paper width check box, and then click Send.

The settings here are also applied under Direct Printing from a digital camera.

Error Regarding Automatic Print Head Alignment Is Displayed

- **Check: See [Eleven flashes: in Alarm Lamp Flashes Orange](#) and take the appropriate action.**



Writing Error/Output Error/Communication Error

- **Check 1: If the Power lamp is off, make sure that the power plug is plugged in, then turn the printer on.**

While the **Power** lamp is flashing green, the printer is initializing. Wait until the **Power** lamp stops flashing and remains lit green.

- **Check 2: Make sure that the printer port is configured appropriately in the printer driver.**

* In the following instructions, "XXX" signifies your printer's name.

1. Log on as a user account with administrator privilege.

2. Click Control Panel, then Printer under Hardware and Sound.

In Windows XP, click Control Panel, Printers and Other Hardware, then Printers and Faxes.

In Windows 2000, click Control Panel then Printers.

3. Right-click the Canon XXX icon, then select Properties.

4. Click the Ports tab to confirm the port settings.

Make sure that a port named USBnnn (where "n" is a number) with Canon XXX appearing in the Printer column is selected for Print to the following port(s).

If the port setting is not correct, reinstall the printer driver or change the port setting

according to the interface you are using.

- **Check 3: Make sure that the USB cable is securely plugged in to the printer and the computer.**

- If you are using a relay device such as a USB hub, disconnect it, connect the printer directly to the computer, and try printing again. If printing starts normally, there is a problem with the relay device. Consult the reseller of the relay device for details.
- There could also be a problem with the USB cable. Replace the USB cable and try printing again.

- **Check 4: Make sure that the printer driver is installed correctly.**

Uninstall the printer driver following the procedure described in [Uninstalling the Printer Driver](#) and reinstall it following the procedure described in your setup manual.

- **Check 5: Check the status of the device on your computer.**

Follow the procedure below to check the status of the device.

1. Click Control Panel, Hardware and Sound, then Device Manager.

If the User Account Control screen is displayed, follow the on-screen instructions.

In Windows XP, click Control Panel, Performance and Maintenance, System, then click Device Manager on the Hardware sheet.

In Windows 2000, click Control Panel, System, then Device Manager on the Hardware sheet.

2. Double-click Universal Serial Bus controllers then USB Printing Support.

If USB Printing Support is not displayed, make sure that the printer is correctly connected to the computer.

➔ [Check 3: Make sure that the USB cable is securely plugged in to the printer and the computer.](#)

3. Click the General tab and make sure that there is no indication of a problem with the device.

If a device error is displayed, refer to Windows help to resolve the error.

Macintosh Error Number: 92 Is Displayed

- **Check: Is the paper size that cannot feed from the Rear Tray selected in the printer driver?**

Click Delete Job in the dialog box that is displayed. Select Quality & Media from the pop-up menu in the Print dialog box and select Front Tray from Paper Source. Then load the paper in the Front Tray and try printing again.

Macintosh Error Number: 93 Is Displayed

- **Check: Is the paper size that cannot feed from the Front Tray selected in the printer driver?**

Click Delete Job in the dialog box that is displayed. Select Quality & Media from the pop-up menu in the Print dialog box and select Rear Tray from Paper Source. Then load the paper in the Rear Tray and try printing again.

Macintosh Error Number: 300 Is Displayed

- **Check 1: If the Power lamp is off, make sure that the power plug is plugged in, then turn the printer on.**

While the **Power** lamp is flashing green, the printer is initializing. Wait until the **Power** lamp stops flashing and remains lit green.

- **Check 2: Make sure that the USB cable is securely plugged in to the printer and**

the computer.

- If you are using a relay device such as a USB hub, disconnect it, connect the printer directly to the computer, and try printing again. If printing starts normally, there is a problem with the relay device. Consult the reseller of the relay device for details.
 - There could also be a problem with the USB cable. Replace the USB cable and try printing again.
- **Check 3: Make sure that your printer's name is selected in the Print dialog box.**
- ➔ [Opening the Page Setup and Print Dialog Box \(Macintosh\)](#)

Macintosh Error Number: 1281 Is Displayed

- **Check: Is the Front Tray up when printing from the Rear Tray starts?**
Return the Front Tray to its normal printing position, make sure that paper is loaded in the Rear Tray, then press the **RESUME/CANCEL** button on the printer to resume printing. Refer to [Loading Paper](#) for details about how to return the Front Tray to its normal printing position.

Macintosh Error Number: 1283 Is Displayed

- **Check: If the Front Tray is pulled up while printing from the Rear Tray, return the Front Tray to its normal printing position, then press the RESUME/CANCEL button on the printer and try printing again.**
Refer to [Loading Paper](#) for details about how to return the Front Tray to its normal printing position.
Do not move the Front Tray during printing.

Macintosh Error Number: 1284 Is Displayed

- **Check: If the Front Tray is pulled down while printing from the Front Tray, return the Front Tray to the Front Paper Feeding Position, then press the RESUME/CANCEL button on the printer and try printing again.**
Refer to [Loading Paper](#) for details about how to return the Front Tray to its normal printing position.
Do not move the Front Tray during printing.

Macintosh Error Number: 1320 Is Displayed

- **Check: Is the printer ready to feed paper from the Front Tray?**
Load the paper correctly in the Front Tray and press the **RESUME/CANCEL** button on the printer.
Refer to [Loading Paper](#) for details about how to load the paper correctly in the Front Tray.

Macintosh Error Number: 1321 Is Displayed

- **Check: Is the paper loaded correctly in the Front Tray?**
Press the **RESUME/CANCEL** button on the printer to clear the error, and then load the paper correctly in the Front Tray according to the procedure described in [Loading Paper](#) and try printing again.

Macintosh Error Number: 1700 Is Displayed

- **See [Eight flashes: in Alarm Lamp Flashes Orange](#) and take the appropriate action.**

Macintosh Ink Info Number: 1600 Is Displayed

- See **Four flashes: in Alarm Lamp Flashes Orange** and take the appropriate action.

Macintosh Ink Info Number: 1683 Is Displayed

- See **Thirteen flashes: in Alarm Lamp Flashes Orange** and take the appropriate action.

Macintosh Ink Info Number: 1688 Is Displayed

- See **Sixteen flashes: in Alarm Lamp Flashes Orange** and take the appropriate action.

Macintosh Error Number: 1851 Is Displayed

- Check: Close the Inner Cover, then press the RESUME/CANCEL button on the printer.

Macintosh Error Number: 1856 Is Displayed

- Check: Close the Inner Cover, then press the RESUME/CANCEL button on the printer.

A page of print data being sent at the time of the error will be erased, so print that page again.

Macintosh Error Number: 2001 Is Displayed

- See **Nine flashes: in Alarm Lamp Flashes Orange** and take the appropriate action.

Macintosh Error Number: 2002 Is Displayed

- See **Nineteen flashes: in Alarm Lamp Flashes Orange** and take the appropriate action.

Macintosh Error Number: 2500 Is Displayed

- See **Eleven flashes: in Alarm Lamp Flashes Orange** and take the appropriate action.

Windows Other Error Messages

- Check: If an error message is displayed outside the printer status monitor, check the following:
 - "Could not spool successfully due to insufficient disk space"
Delete any unnecessary files to increase the amount of free space on the disk.
 - "Could not spool successfully due to insufficient memory"
Quit other running applications to increase available memory.
If you still cannot print, restart your computer and retry printing.
 - "Printer driver could not be found"
Uninstall the printer driver according to the procedure described in [Uninstalling the](#)

Printer Driver, and then reinstall it.

- "Could not print Application name - File name"
Try printing again once the current job is complete.

Windows The Inkjet Printer/Scanner/Fax Extended Survey Program Screen Is Displayed

If the Inkjet Printer/Scanner/Fax Extended Survey Program is installed, a confirmation screen asking for permission to send the printer usage information will be displayed three months and then six months after the installation. After that, it will be displayed every six months for about four years.

Read the instructions on the screen and follow the procedure below.

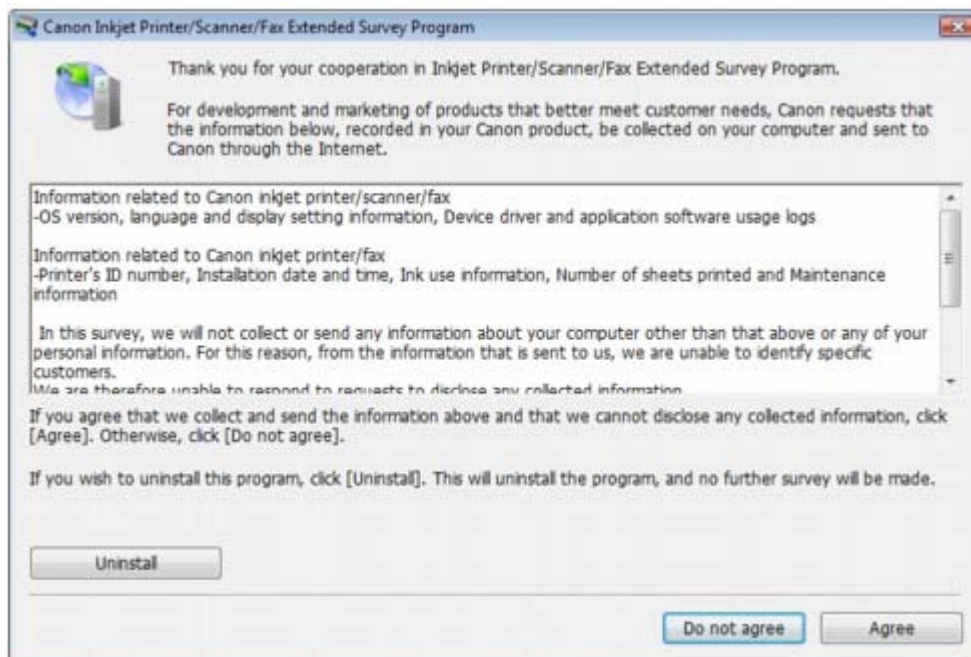

• If you agree to participate in the survey program:

Click Agree, then follow the on-screen instructions. The printer usage information will be sent to Canon via the Internet. If you have followed the on-screen instructions, the information will be sent automatically from the second time onward and the confirmation screen will not be displayed again.

Note

- When the information is being sent, a caution screen such as an Internet security screen may be displayed. In this case, confirm that the program name is "IJPLMU1.exe", then allow it.
- If you deselect the Send automatically from the next time check box, the information will not be sent automatically from the second time onward and a confirmation screen will be displayed at the time of the next survey. To send the information automatically, see [Changing the confirmation screen setting:](#)

• If you do not agree to participate in the survey program:

Click Do not agree. The confirmation screen will be closed, and the survey at that time is skipped. The confirmation screen will be displayed again three months later.

• To uninstall the Inkjet Printer/Scanner/Fax Extended Survey Program:

To uninstall the Inkjet Printer/Scanner/Fax Extended Survey Program, click Uninstall, then follow the on-screen instructions.

• Changing the confirmation screen setting:

1. Select items the Start menu as shown below.
 - In Windows Vista, select the Start menu > Control Panel > Programs and Features > Uninstall a program.
 - In Windows XP, select the Start menu > Control Panel > Add or Remove Programs.
 - In Windows 2000, select the Start menu > Settings > Control Panel > Add/Remove Programs.

Note

- In Windows Vista, a confirmation/warning dialog box may appear when installing, uninstalling or starting up software. This dialog box appears when administrative rights are required to perform a task. If you are logged on to an administrator account, click Continue or Allow to continue.

2. Select Canon Inkjet Printer/Scanner/Fax Extended Survey Program.
3. Select Change.

If you select Yes after you have followed the on-screen instructions, the confirmation screen will be displayed at the time of the next survey.

If you select No, the information will be sent automatically.

Note

- If you select Uninstall (or Remove), the Inkjet Printer/Scanner/Fax Extended Survey Program is uninstalled. Follow the on-screen instructions.

Macintosh The Inkjet Printer/Scanner/Fax Extended Survey Program Icon Appears

If the Inkjet Printer/Scanner/Fax Extended Survey Program is installed, the printer usage information is scheduled to be sent three months and then six months after the installation. After that, it is scheduled to be sent every six months for about four years. The Inkjet Printer/Scanner/Fax Extended Survey Program icon appears in the Dock when it is time to send the printer usage information.

In Mac OS X v.10.3.9, the Inkjet Printer/Scanner/Fax Extended Survey Program is not installed.

Read the instructions on the screen after clicking the icon, then follow the procedure below.

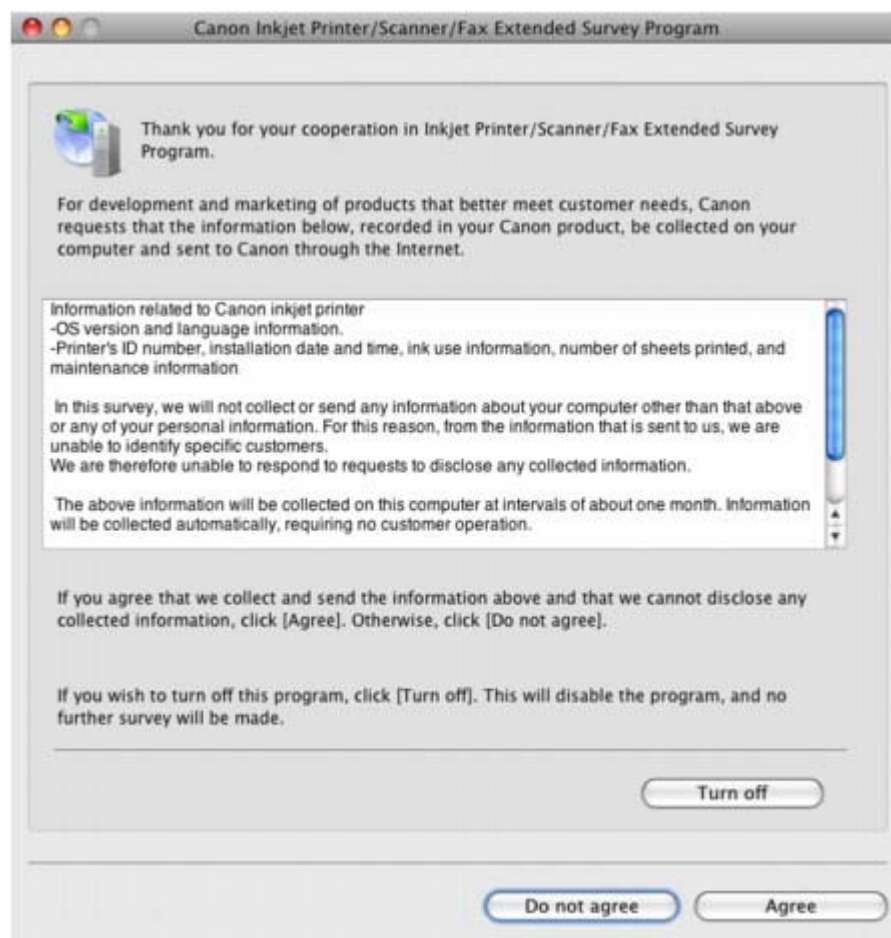

• If you agree to participate in the survey program:

Click Agree, then follow the on-screen instructions. The printer usage information will be sent to Canon via the Internet. If you have followed the on-screen instructions, the information will be sent automatically from the second time onward and the confirmation screen will not be displayed again.

Note

- If you deselect the Send automatically from the next time check box, the information will not be sent automatically from the second time onward and the Inkjet Printer/Scanner/Fax Extended Survey Program icon will appear in the Dock at the time of the next survey.

- **If you do not agree to participate in the survey program:**

Click Do not agree. The confirmation screen will be closed, and the survey at that time is skipped. The confirmation screen will be displayed again three months later.

- **To stop sending the information:**

Click Turn off. The Inkjet Printer/Scanner/Fax Extended Survey Program is stopped, and the information will not be sent. To resume the survey, see [Changing the setting](#).

- **To uninstall the Inkjet Printer/Scanner/Fax Extended Survey Program:**

1. Stop the Inkjet Printer/Scanner/Fax Extended Survey Program.
➔ [Changing the setting](#):
2. Select Applications from the Go menu, and double-click the Canon Utilities folder, then the Canon Inkjet Printer/Scanner/Fax Extended Survey Program folder.
3. Place the Canon Inkjet Printer/Scanner/Fax Extended Survey Program.app file into the Trash.
4. Restart the computer.
Empty the Trash and restart your computer.

- **Changing the setting:**

To display the confirmation screen every time the printer usage information is sent or to resume surveying, follow the procedure below.

1. Select Applications from the Go menu, and double-click the Canon Utilities folder, then the Canon Inkjet Printer/Scanner/Fax Extended Survey Program folder.
2. Double-click the Canon Inkjet Printer/Scanner/Fax Extended Survey Program icon.

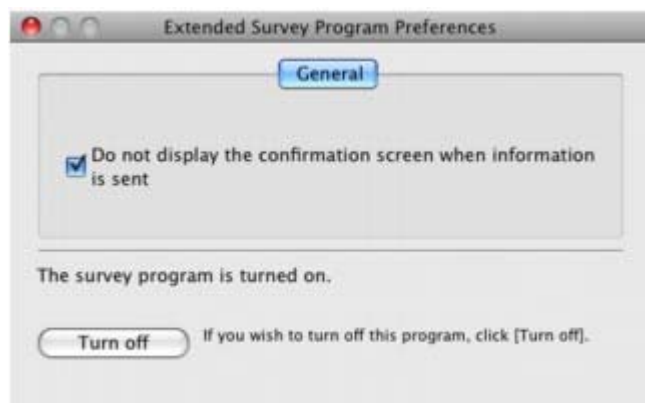

- **Do not display the confirmation screen when information is sent:**
If the check box is selected, the information will be sent automatically.
If the check box is not selected, the Inkjet Printer/Scanner/Fax Extended Survey Program icon will appear in the Dock at the time of the next survey. Click the icon, then follow the on-screen instructions.
- **Turn off/Turn on button:**
Click the Turn off button to stop the Inkjet Printer/Scanner/Fax Extended Survey Program.
Click the Turn on button to restart the Inkjet Printer/Scanner/Fax Extended Survey Program.

Advanced Guide

Advanced Guide > Troubleshooting > For Windows Users

For Windows Users

Printer Status Monitor Is Not Displayed

- **Check: Is the printer status monitor enabled?**

Make sure that Enable Status Monitor is selected on the Option menu of the printer status monitor.

- 1. Open the printer properties dialog box.**

➡ [Opening the Printer Properties Dialog Box \(Windows\)](#)

- 2. On the Maintenance sheet, click View Printer Status.**

- 3. Select Enable Status Monitor on the Option menu if it is not selected.**

[Page top](#) ↕

Advanced Guide

Advanced Guide > Troubleshooting > Error Message Appears on a PictBridge Compliant Device

Error Message Appears on a PictBridge Compliant Device

The following are the possible errors that may occur when printing directly from a PictBridge compliant device and the countermeasures to clear them.

Note

- This section describes errors that are indicated on Canon-brand PictBridge compliant devices. The error messages and operations may vary depending on the device you are using. For errors on non-Canon PictBridge compliant devices, check the status of the **Alarm** lamp and take the appropriate action to clear the error. For details, see [Alarm Lamp Flashes Orange](#).
- For the errors indicated on the PictBridge compliant device and their solution, also refer to the instruction manual of the device. For other troubles on the device, contact the manufacturer.

Error Message on the PictBridge Compliant Device	Action
"Printer in use"	If the printer is printing from the computer or warming up, wait until the job ends. When it is ready, the printer starts printing automatically.
"No paper"	Load paper, and select Continue* in the display on your PictBridge compliant device. * To resume printing, you can also press the RESUME/CANCEL button on the printer instead of selecting Continue on the device.
"Paper Error"/"Media type error"	Check the number of how many the Alarm lamp flashes and take the appropriate action to resolve the error. ➔ Alarm Lamp Flashes Orange
"Paper jam"	Select Stop in the display on your PictBridge compliant device to stop printing. Remove the jammed paper, load new paper, press the RESUME/CANCEL button on the printer, then try printing again.
"Printer cover open"	Close the Top Cover on the printer.
"No print head"	The Print Head is defective or is not installed. See Five flashes : in Alarm Lamp Flashes Orange and take the appropriate action.
"Waste tank full"/"Ink absorber full"	The ink absorber is nearly full. See Eight flashes : in Alarm Lamp Flashes Orange and take the appropriate action.
"No ink"/"Ink cassette error"	The ink tank is not installed properly or empty. Check the number of how many the Alarm lamp flashes and take the appropriate action to resolve the error. ➔ Alarm Lamp Flashes Orange
"Ink Error"	An ink tank that was once empty is installed. See Thirteen flashes : in Alarm Lamp Flashes Orange and take the appropriate action.
"Hardware Error"	Ink tank errors have occurred. Replace the ink tank. ➔ Routine Maintenance
"Printer error"	An error requiring servicing may have occurred. (The Power lamp flashes green and Alarm lamp flashes orange alternately.) ➔ Power Lamp Flashes Green and Alarm Lamp Flashes Orange Alternately Disconnect the USB cable between the printer and the PictBridge compliant device, turn off the printer, and unplug

the power cord of the printer from the power supply.
Plug the power cord of the printer back in, turn on the printer,
and then reconnect the PictBridge compliant device to the
printer.
If the same error occurs, contact the service center.

[Page top](#) ↕

Advanced Guide

Advanced Guide > Troubleshooting > FAQs

FAQs

- ➔ No Printing Results/Printing Is Blurred/Colors Are Wrong/White Streaks
- ➔ Printer Moves But Ink Is Not Ejected
- ➔ Cannot Install the Printer Driver
- ➔ Printing Does Not Start
- ➔ Printing Stops Before It Is Completed
- ➔  Writing Error/Output Error/Communication Error
- ➔ Print Results Not Satisfactory
- ➔ Paper Jams
- ➔ Paper Does Not Feed Properly

[Page top](#) 

Advanced Guide

Advanced Guide > Troubleshooting > If You Cannot Resolve the Problem

If You Cannot Resolve the Problem

If you cannot resolve the problem with any of the workarounds in this chapter, please contact the seller of the printer or the service center.

Canon support staff are trained to be able to provide technical support to satisfy customers.

Caution

- If the printer emits any unusual sound, smoke, or odor, turn it off immediately. Unplug the power cord from the outlet and contact the seller or the service center. Never attempt to repair or disassemble the printer yourself.
 - Attempts by customers to repair or take apart the printer will invalidate any warranty regardless of whether the warranty has expired.
-

Before contacting the service center, confirm the following:

- Product name:
 - * Your printer's name is located on the front cover of the setup manual.
- Serial number: please refer to the setup manual
- Details of the problem
- What you tried to solve the problem, and what happened

[Page top](#) 

Advanced Guide

Advanced Guide > Troubleshooting > Instructions for Use (Printer Driver)

Instructions for Use (Printer Driver)

This printer driver is subject to the following restrictions. Keep the following points in mind when using the printer driver.

Restrictions on the Printer Driver

- With some applications, the Copies setting in the Page Setup tab of the printer driver may not be enabled.
In this case, use the copies setting in the Print dialog box of the application software.
- If the selected Language in the About dialog box does not match the operating system interface language, the driver screen may not be displayed properly.
- Do not change the Advanced tab items of the printer properties. If you change any of the items, you will not be able to use the following functions correctly.
Also, if Print to file is selected in the Print dialog box of the application software and with applications that prohibit EMF spooling, such as Adobe Photoshop LE and MS Photo Editor, the following functions will not operate.
 - Preview before printing on the Main tab
 - Prevent loss of print data in the Print Options dialog box
 - Page Layout, Poster, Booklet, Duplex Printing, Specify Margin..., Print from Last Page, Collate, and Stamp/Background... on the Page Setup tab
- Since the resolution in the preview display differs from the printing resolution, text and lines in the preview display may appear different from the actual print result.
- With some applications, the printing is divided into multiple print jobs.
To cancel printing, delete all divided print jobs.
- If image data is not printed correctly, display the Print Options dialog box from the Page Setup tab and change the setting of Disable ICM required from the application software. This may solve the problem.
- Software windows may not appear correctly on Windows Vista when fonts are set to Larger scale. If you want to display the windows with Larger scale fonts, set the desktop theme to Windows Classic as follows:
 1. Select Control Panel from the Start menu.
 2. Select Appearance and Personalization -> Personalization -> Theme.
The Theme Settings dialog box opens.
 3. At the Theme Settings dialog box, click the Themes tab, and select Windows Classic from Theme.
 4. Click OK.
Desktop changes to Windows Classic display.

Points to Note with Applications

- There are following restrictions in Microsoft Word (Microsoft Corporation).
 - If Microsoft Word has the same printing functions as the printer driver, use Word to specify them.
 - When selecting Scaled, Fit-to-Page, or Page Layout from the Page Layout list on the Page Setup tab, the selected printing function may not be effective, depending on the version of Word.
If this happens, follow the procedure below.
 1. Open Word's Print dialog box.
 2. Open the printer driver setup window, specify Page Layout on the Page Setup tab, and click OK.

3. Without starting printing, close the Print dialog box.
 4. Open Word's Print dialog box again.
 5. Open the printer driver setup window again and click OK.
 6. Start printing.
- Illustrator/Adobe Systems Inc.
If Bitmap Printing takes effect, printing may take time or some data may not be printed. Print after clearing the Bitmap Printing check box in the Print dialog box.

[Page top ↑](#)

Advanced Guide

Advanced Guide > Appendix

Appendix

- ➔ XPS Printer Driver
- ➔ Before printing on Art Paper
- ➔ Printing Area
- ➔ Deleting the Undesired Print Job
- ➔ Updating the Printer Driver
- ➔ Uninstalling the On-Screen Manuals
- ➔ Transporting the Printer
- ➔ Opening the Printer Properties Dialog Box (Windows)
- ➔ Opening the Page Setup and Print Dialog Box (Macintosh)
- ➔ Opening the Canon IJ Printer Utility (Macintosh)
- ➔ Sharing the Printer on a Network

[Page top](#) ↑

Advanced Guide

Advanced Guide > Appendix > XPS Printer Driver

XPS Printer Driver

The following two printer drivers can be installed on Windows Vista:

- IJ printer driver
- XPS printer driver

In this topic, the above drivers are indicated as "standard IJ printer driver" and "XPS printer driver" respectively.

Using the XPS printer driver enables you to print in the High Dynamic Range (full 16-bit workflow). Use the XPS printer driver only when printing in the High Dynamic Range.

Important

- To use the XPS printer driver, the standard IJ printer driver must already be installed on your computer.

Installing the XPS Printer Driver

Load the Setup CD-ROM that comes with the printer, and install the XPS printer driver from Custom Install.

Using the XPS Printer Driver

To use the XPS printer driver for printing, open the Print dialog box in application you are using, and select "your printer name XPS."

For detailed operating instructions, see Help of the XPS printer driver.

[Page top ↑](#)

Advanced Guide

Advanced Guide > Appendix > Before Printing on Art Paper

Before Printing on Art Paper

When using art paper, dust is liable to be generated. It is therefore recommended that paper dust be removed on art paper just before printing.

- **You will need a soft hair brush (or similar brush used to clean office automation equipment).**

The wider the brush, the more effective it will be.



Important

- Be sure not to use brushes as shown below. The printing surface may be damaged.

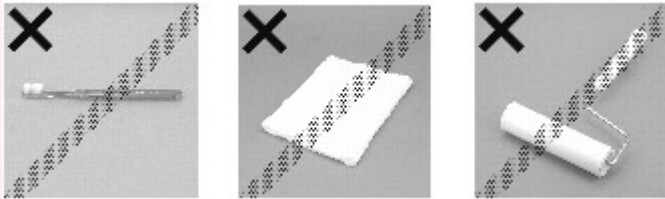

- **Paper dust removal procedure:**

1. Check that the brush is not wet and free from dust or dirt.
2. Brush the overall printing surface carefully in one direction.

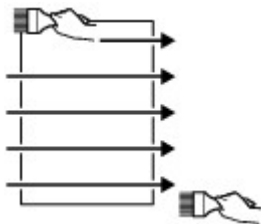

Important

- Be sure to brush all the way across the paper; do not start brushing at the middle or stop halfway.
- Be careful not to touch the printing surface as much as possible.

3. To complete the removal of paper dust, brush the paper in the other direction from top to bottom.

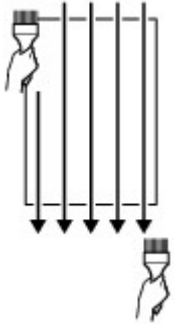

[Page top](#) ↑

Advanced Guide

Advanced Guide > Appendix > Printing Area

Printing Area

To ensure the best print quality, the printer allows a margin along each edge of media. The actual printable area will be the area inside these margins.

Recommended printing area : Canon recommends that you print within this area.

Printable area : The area where it is possible to print.

However, printing in this area can affect the print quality or the paper feed precision.

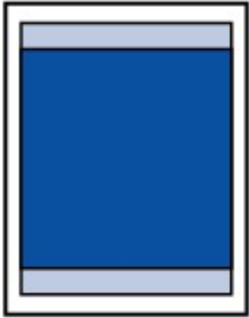

Note

■ **Borderless Printing**

- By selecting Borderless Printing option, you can make prints with no margins.
- When performing Borderless Printing, slight cropping may occur at the edges since the printed image is enlarged to fill the whole page.
- For Borderless Printing, use the following paper:
 - Glossy Photo Paper "Everyday Use" GP-501
 - Photo Paper Glossy GP-502
 - Photo Paper Plus Semi-Gloss SG-201
 - Photo Paper Pro Platinum PT-101
 - Photo Paper Plus Glossy II PP-201
 - Photo Paper Pro II PR-201
 - Matte Photo Paper MP-101

Performing Borderless Printing on any other type of paper may substantially reduce printing quality and/or result in printouts with altered color hues.

Borderless Printing on plain paper may result in printouts with reduced quality. Use them only for test printing. You can perform Borderless Printing on plain paper only when printing from your computer.

- Depending on the type of paper, Borderless Printing may reduce the print quality at the top and bottom edges of the paper or cause these parts to become smudged.
- When printing in grayscale, depending on an image, the printing troubles may occur on the top and/or bottom edges of the paper such as uneven coloration or white streaks.

➡ [Colors Are Uneven or Streaked](#)

➡ [Letter, Legal](#)

➡ [Envelopes](#)

➡ [Other Sizes than Letter, Legal, Envelopes](#)

➡ [Sizes for Art Paper](#)

Advanced Guide

Advanced Guide > Appendix > Printing Area > Other Sizes than Letter, Legal, Envelopes

Other Sizes than Letter, Legal, Envelopes

Size	Printable Area (width x height)
A5	5.56 x 7.95 inches / 141.2 x 202.0 mm
A4	8.00 x 11.38 inches / 203.2 x 289.0 mm
A3	11.4 x 16.2 inches / 290.2 x 412.0 mm
A3+ (13" x 19" / 32.9 x 48.3 cm)	12.7 x 18.7 inches / 322.2 x 475.0 mm
B5	6.90 x 9.80 inches / 175.2 x 249.0 mm
B4	9.9 x 14 inches / 250.2 x 356.0 mm
4" x 6" / 10 x 15 cm	3.73 x 5.69 inches / 94.8 x 144.4 mm
4" x 8" / 10 x 20 cm	3.73 x 7.69 inches / 94.8 x 195.2 mm
5" x 7" / 13 x 18 cm	4.73 x 6.69 inches / 120.2 x 169.8 mm
11" x 17" / 279.4 x 431.8 mm	10.7 x 16.7 inches / 272.6 x 423.8 mm
8" x 10" / 20 x 25 cm	7.73 x 9.69 inches / 196.4 x 246.0 mm
10" x 12" / 254.0 x 304.8 mm	9.7 x 11.7 inches / 247.2 x 296.8 mm
14" x 17" / 355.6 x 431.8 mm	13.7 x 16.7 inches / 348.8 x 423.8 mm
Wide	3.73 x 6.80 inches / 94.8 x 172.6 mm

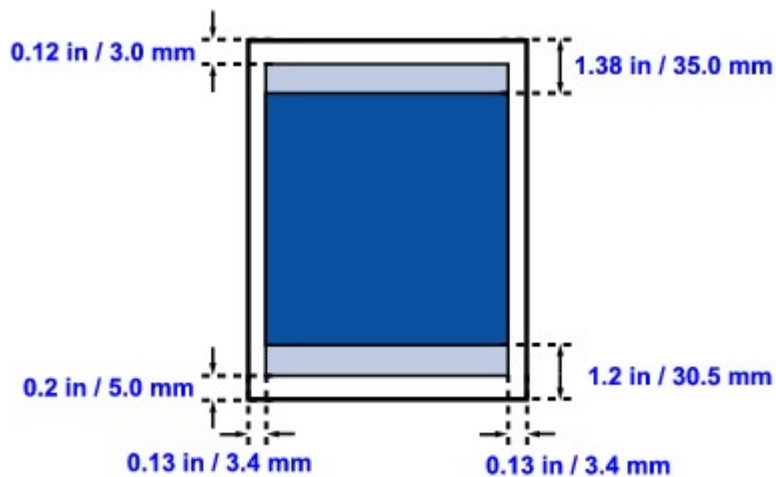

- Recommended printing area
- Printable area

Advanced Guide

Advanced Guide > Appendix > Printing Area > Letter, Legal

Letter, Legal

Size	Printable Area (width x height)
Letter	8.00 x 10.69 inches / 203.2 x 271.4 mm
Legal	8.00 x 13.69 inches / 203.2 x 347.6 mm

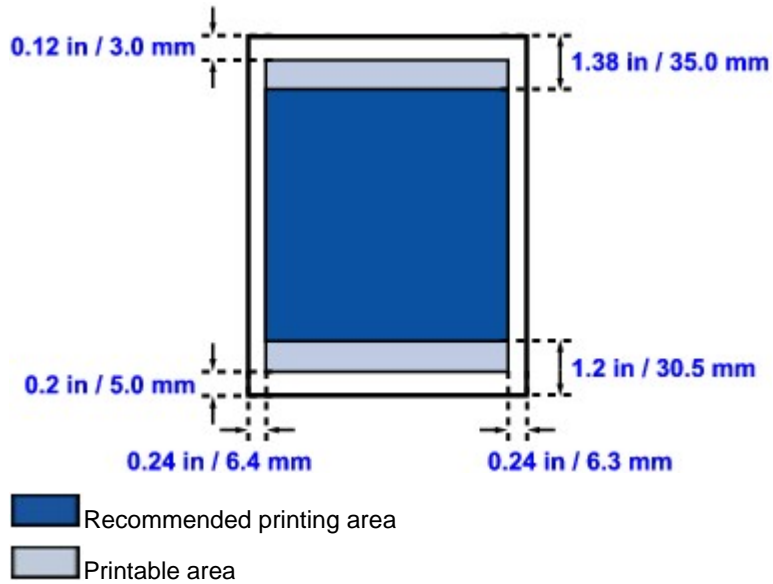

[Page top](#) ↕

Advanced Guide

Advanced Guide > Appendix > Printing Area > Sizes for Art Paper

Sizes for Art Paper

When using the Art Paper or non Canon genuine specialty paper, printing is not done in a 1.38 inches / 35 mm margin along the top and bottom edges. A limit is set to prevent printing along a 1.38 inches / 35 mm margin on the top and bottom edges when a paper size for Art Paper is selected in the printer driver.

Art A4 (Margin 35), Art A3 (Margin 35), Art A3+ (Margin 35)

Size	Printable Area (width x height)
Art A4 (Margin 35)	8.0 x 8.9 inches / 203.2 x 227.0 mm
Art A3 (Margin 35)	11.4 x 13.8 inches / 290.2 x 350.0 mm
Art A3+ (Margin 35)	12.7 x 16.3 inches / 322.2 x 413.0 mm

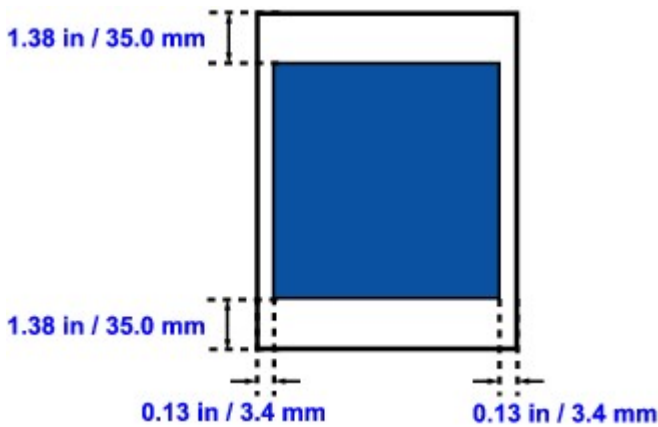

 Recommended printing area

Art Letter (Margin 35)

Size	Printable Area (width x height)
Art Letter (Margin 35)	8.0 x 8.2 inches / 203.2 x 209.4 mm

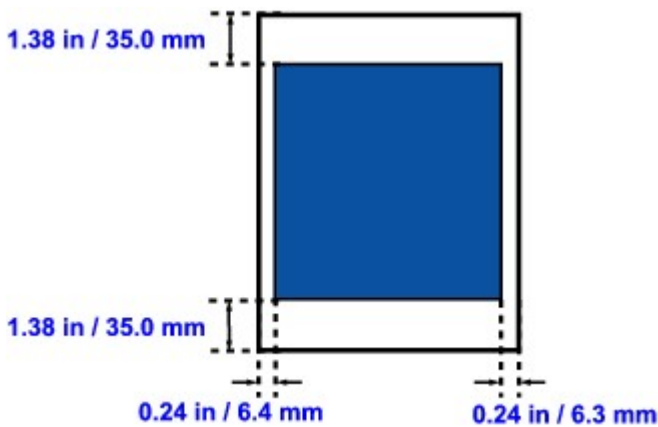

 Recommended printing area

Advanced Guide

Advanced Guide > Appendix > Printing Area > Envelopes

Envelopes

Size	Recommended Printing Area (width x height)
European DL*	4.06 x 7.50 inches / 103.2 x 190.5 mm
US Comm. Env. #10*	3.86 x 8.34 inches / 98.0 x 211.8 mm

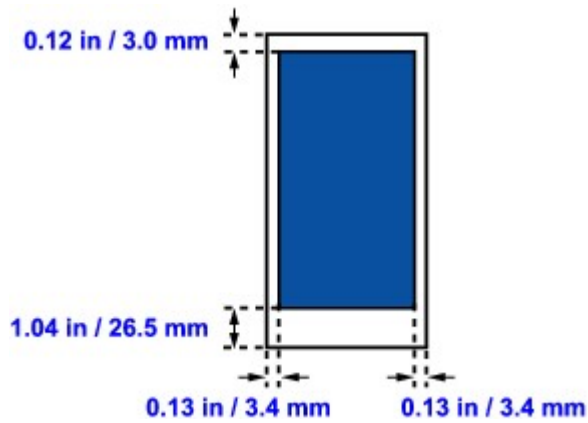

 Recommended printing area

[Page top ↕](#)

Advanced Guide

Advanced Guide > Appendix > Deleting the Undesired Print Job

Deleting the Undesired Print Job

If the printer does not start printing, the print job data cancelled or failed may be remaining. Delete the undesired print job by using the Canon IJ Status Monitor.

1. Display the Canon IJ Status Monitor

Click the Status Monitor button displayed on the Task Bar.
The Canon IJ Status Monitor appears.

2. Display the print jobs

Click Display Print Queue....
The print queue window opens.

3. Delete the print jobs

Select Cancel All Documents from the Printer menu.
When the confirmation message appears, click Yes.
The print job is deleted.

Important

- Users who have not been granted access permission for printer management cannot delete the print job of another user.

Note

- When you perform this operation, all print jobs are deleted. If the print queue list contained a necessary print job, start the printing process over from the beginning.

Advanced Guide

[Advanced Guide](#) > [Appendix](#) > [Updating the Printer Driver](#)

Updating the Printer Driver

- ➔ [Obtaining the Latest Printer Driver](#)
- ➔ [Uninstalling the Printer Driver](#)
- ➔ [Before Installing the Printer Driver](#)
- ➔ [Installing the Printer Driver](#)

[Page top](#) ↑

Advanced Guide

[Advanced Guide](#) > [Appendix](#) > [Updating the Printer Driver](#) > [Obtaining the Latest Printer Driver](#)

Obtaining the Latest Printer Driver

By updating the printer driver to the latest version of the printer driver, unresolved problems may be solved.

You can check the version of the printer driver by clicking the About... button on the Maintenance tab.

Access our web site through the Internet and download the latest printer driver for your model.

Important

- You can download the printer driver for free, but any Internet access charges incurred are your responsibility.
- Before installing the latest printer driver, delete the previously installed version. For information on how to delete the printer driver, refer to [Uninstalling the Printer Driver](#).

Related Topics

- [➡ Before Installing the Printer Driver](#)
- [➡ Installing the Printer Driver](#)

[Page top](#) ↑

Advanced Guide

Advanced Guide > Appendix > Updating the Printer Driver > Uninstalling the Printer Driver

Uninstalling the Printer Driver

The printer driver you no longer use can be deleted.
When deleting the printer driver, first exit all programs that are running.

The procedure to delete the unnecessary printer driver is as follows:

If There is an Uninstaller

1. Start the uninstaller

- In Windows Vista or Windows XP, select the Start menu -> All Programs -> "Your model name" -> Printer Driver Uninstaller.
- In Windows 2000, select the Start menu -> Programs -> "Your model name" -> Printer Driver Uninstaller.

The Printer Driver Uninstaller dialog box is displayed.

Important

- In Windows Vista, a confirmation/warning dialog box may appear when installing, uninstalling or starting software.
This dialog box appears when administrative rights are required to perform a task.
If you are logged on to an administrator account, click Continue or Allow to continue.
Some applications require an administrator account to continue. If you are logged on to a standard account, switch to an administrator account, and restart the operation from the beginning.

2. Execute the uninstaller

Click Execute. When the confirmation message appears, click Yes.
When all the files have been deleted, click Complete.
The deletion of the printer driver is completed.

If There is No Uninstaller

If there is no uninstaller in the Start menu of Windows Vista, follow these steps:

1. Select the printer to be deleted

Select the Start menu -> Control Panel -> Hardware and Sound -> Printers.
Click the model to delete, then press the Alt key on your keyboard. On the File menu, click Delete.

2. Delete the printer

If the User Account Control dialog box appears, click Continue. Then when the confirmation message appears, click Yes.
The icon is deleted.

3. Select the printer driver to be deleted

Press the Alt key. On the File menu, select Run as administrator, and then click Sever Properties....
If the User Account Control dialog box appears, click Continue.
Click the Drivers tab. In the Installed printer drivers list, click the printer to delete.

4. Delete the printer driver

When you click Remove..., Remove Driver And Package dialog box is displayed.
Select Remove driver and driver package, and then click OK.
In the confirmation dialog box, click Yes.
When data collection is completed in the Remove Driver Package dialog box, click Delete.

5. Click OK.

The deletion of the printer driver is complete.

 Important

- You may not be able to delete the printer driver properly from the Installed printer drivers list. If this happens, restart your computer, and try again.

[Page top](#) ↑

Advanced Guide

[Advanced Guide](#) > [Appendix](#) > [Updating the Printer Driver](#) > [Before Installing the Printer Driver](#)

Before Installing the Printer Driver

This section describes the items that you should check before installing the printer driver. You should also refer to this section if the printer driver cannot be installed.

Check the Printer Status

- Properly connect the personal computer and the printer. For details on connection instructions, refer to the "Install the Software" in the manual: Getting Started.
- Turn off the printer.

Check the Personal Computer Settings

- Terminate all running applications.
- In Windows Vista, log on as a user who has the administrator rights.
In Windows XP, log on as the computer administrator.
In Windows 2000, log on as a member of the Administrators group.

Note

- If an old version of the printer driver is already installed, first delete (uninstall) that version. For instructions on deleting the printer driver, see [Uninstalling the Printer Driver](#).
-

Related Topics

- ➔ [Obtaining the Latest Printer Driver](#)
- ➔ [Installing the Printer Driver](#)

[Page top](#) ↑

Advanced Guide

Advanced Guide > Appendix > Updating the Printer Driver > Installing the Printer Driver

Installing the Printer Driver

You can access our web site through the Internet and download the latest Printer Driver for your model.

The procedure for installing the downloaded Printer Driver is as follows:

1. Turn off the printer

Important

- If you turn on the computer while the printer is on, the Windows Plug and Play function is executed automatically, and the Found New Hardware window (Windows Vista) or Found New Hardware Wizard window (Windows XP, Windows 2000) is displayed. In this case, click Cancel.

2. Start the installer

Double-click the icon of the downloaded file.
The installation program starts.

Important

- In Windows Vista, a confirmation/warning dialog box may appear when installing, uninstalling or starting software.
This dialog box appears when administrative rights are required to perform a task.
If you are logged on to an administrator account, click Continue or Allow to continue.
Some applications require an administrator account to continue. If you are logged on to a standard account, switch to an administrator account, and restart the operation from the beginning.

3. Install the driver

At the Welcome window, click Next.
Read the contents of the License Agreement window. After checking the contents, click Yes.
Installation of the printer driver begins.

After the Installation Complete window is displayed, check that the printer and the computer are connected through a cable.

To select the connection port for your printer manually, check the Select printer port check box, and click Manual selection. At the Select printer port window, select the connection destination, and then click OK.

4. Complete the installation

Click Complete.
Turn on the printer, and wait awhile until the connection is recognized.

This procedure installs the printer driver.

Depending on the environment you are using, a message prompting you to restart the computer may be displayed. To complete the installation properly, restart the computer.

Important

- You can download the printer driver for free, but any Internet access charges incurred are your responsibility.

Related Topics

- ➔ [Obtaining the Latest Printer Driver](#)
- ➔ [Before Installing the Printer Driver](#)

Advanced Guide

Advanced Guide > Appendix > Uninstalling the On-Screen Manuals

Uninstalling the On-Screen Manuals

Follow the procedure below to uninstall all of the installed on-screen manuals from your computer. Before uninstalling the on-screen manuals, exit all on-screen manuals that are opening.



All of the installed on-screen manuals will be deleted at the same time.

1. Click Start > All Programs (Programs in Windows 2000) > Canon XXX Manual (where "XXX" is your printer's name) > Uninstall.
2. Click OK when the confirmation message appears.

Note

- When the message prompting you to restart your computer is displayed, click OK to restart your computer.

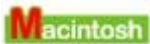

On-screen manuals other than printer driver's help are uninstalled at a time.

1. Select Applications on the Go menu.
2. Double-click the Canon Utilities folder, and then the IJ Manual folder.
3. Drag the folder of your printer's name into the trash.
4. Drag the  Canon XXX On-screen Manual icon (where "XXX" is your printer's name) on your desktop into the trash.

Advanced Guide

Advanced Guide > Appendix > Transporting the Printer

Transporting the Printer

When relocating the printer, pack the printer using the original packing materials.

If you do not have the original packing materials, pack the printer carefully using protective material and place it inside a sturdy box.

Important

- Do not transport or store the printer slanted, vertically, or upside-down, as the ink may leak and damage the printer.

1. Turn the printer off.
2. Confirm that the **Power** lamp is off and unplug the printer.

Important

- Do not unplug the printer while the **Power** lamp is lit or flashing green, as it may cause malfunction or damage to the printer, making the printer unable to print.

3. Retract the Front Tray, the Front Feed Support, and the Paper Support.
4. Disconnect the printer cable from the computer and from the printer, and then disconnect the power plug from the printer.
5. Use adhesive tape to secure all the covers on the printer to keep them from opening during transportation. Then pack the printer in the plastic bag.
6. Attach the protective material to the printer when packing the printer.

Important

- Pack the printer with the Print Head and ink tanks left installed in the printer.

Note

- Clearly label the box as "FRAGILE" or "HANDLE WITH CARE".

Advanced Guide

Advanced Guide > Appendix > Opening the Printer Properties Dialog Box (Windows)

Opening the Printer Properties Dialog Box (Windows)

The printer driver setup window can be displayed through the application software in use or the Start menu of the Windows.

Open the Printer Properties Dialog Box through the Application Software

Follow the procedure below to configure print settings when printing.

1. Select the command you perform printing on the application software in use.

In general, select Print on the File menu to open the Print dialog box.

2. Select your model name and click Preferences (or Properties).

The printer properties dialog box opens.



Note

- Depending on application software you use, command names or menu names may vary and there may be more steps. For details, refer to the user's manual of your application software.

Open the Printer Properties Dialog Box through the Start Menu

Follow the procedure below to perform maintenance operations such as print head cleaning, or to configure print settings that are common for all application software.

1. Select items from the Start menu as shown below.

- In Windows Vista, select the Start menu > Control Panel > Hardware and Sound > Printers.
- In Windows XP, select the Start menu > Control Panel > Printers and Other Hardware > Printers and Faxes.
- In Windows 2000, select the Start menu > Settings > Printers.

2. Right-click your model name icon and then select Printing Preferences from the displayed menu.

The printer properties dialog box opens.



Important

- Opening the printer properties dialog box through Properties displays such tabs regarding the Windows functions as the Ports (or Advanced) tab. Those tabs do not appear when opening through Printing Preferences or application software. About tabs regarding Windows functions, refer to the user's manual for the Windows.

Advanced Guide

Advanced Guide > Appendix > Opening the Page Setup and Print Dialog Box (Macintosh)

Opening the Page Setup and Print Dialog Box (Macintosh)

You can open the Page Setup dialog box and the Print dialog box from the application program you are using.

Opening the Page Setup Dialog Box

Open the Page Setup dialog box to specify page (paper) settings before printing.

- 1. Select Page Setup... on the File menu in your application program.**

The Page Setup dialog box opens.

Opening the Print Dialog Box

Open the Print dialog box to specify print settings before printing.

- 1. Select Print... on the File menu in your application program.**

The Print dialog box opens.

[Page top](#) ↕

Advanced Guide

Advanced Guide > Appendix > Opening the Canon IJ Printer Utility (Macintosh)

Opening the Canon IJ Printer Utility (Macintosh)

To open the Canon IJ Printer Utility, follow the procedure below.

In Mac OS X v.10.5.x

1. Select System Preferences on the Apple menu.
2. Click Print & Fax.
3. Select your printer's name in the Printers and click Open Print Queue....
The job list of your printer is displayed.
4. Click Utility.

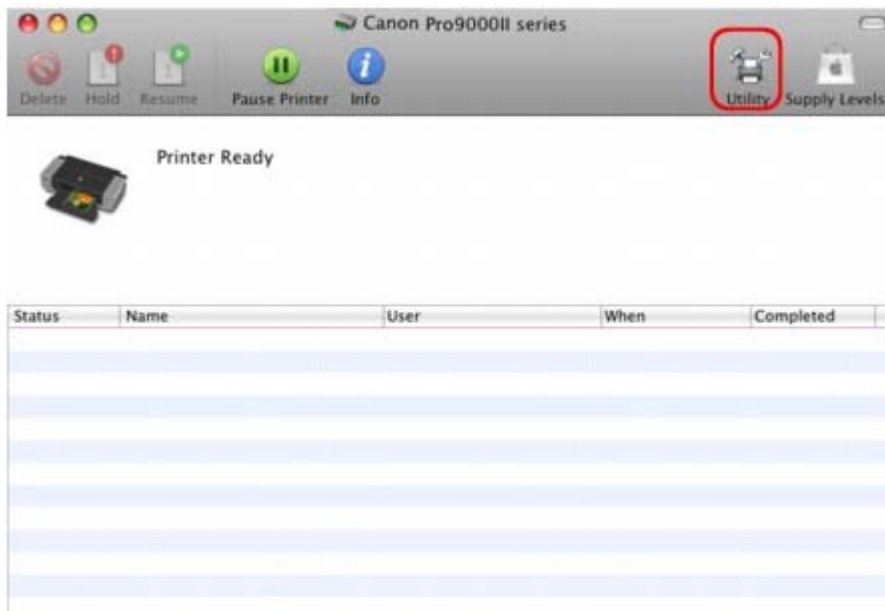

The Printer List opens.

5. Select your printer's name in the Product list and click Maintenance.

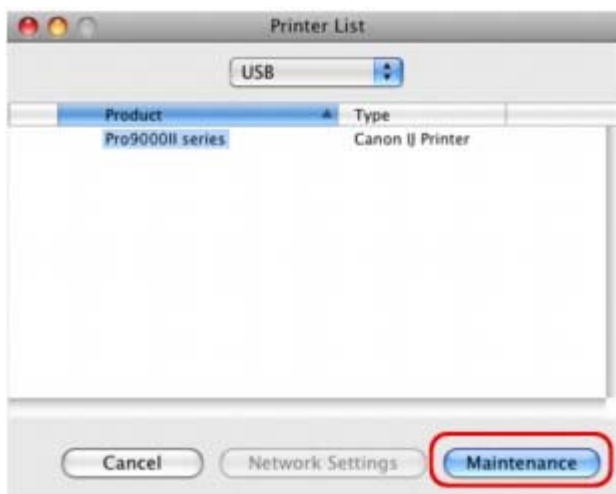

The Canon IJ Printer Utility starts up.

In Mac OS X v.10.4.x or Mac OS X v 10.3.9

1. Select Applications on the Go menu.
2. Double-click the Utilities folder, and then double-click the Printer Setup Utility icon.
The Printer List opens.
3. Select your printer's name in the Name list and click Utility.



4. Select your printer's name in the Product list and click Maintenance.

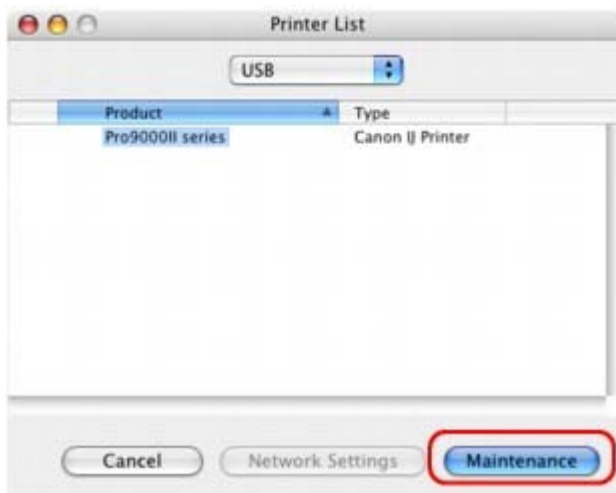

The Canon IJ Printer Utility starts up.

Advanced Guide

Advanced Guide > Appendix > Sharing the Printer on a Network

Sharing the Printer on a Network

If multiple computers are being used in the network environment, you can share the printer connected to one computer with other computers.

The Windows versions of the computers connected to the network do not necessarily have to be the same.

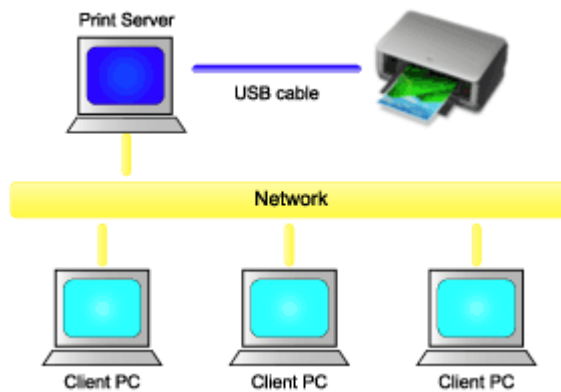

- **Settings on Print Server**

Describes the procedure for setting up a computer directly connected to a printer with a USB cable.

- **Settings on Client PC**

Describes the procedure for setting up those computers that will use this printer through the network.

When you execute print, the data is sent through the print server system to the printer.

Important

- In case an error occurred when a document is printed by the client system to a shared printer, the error message of Canon IJ Status Monitor will be displayed both on the client system and the print server system. For regular printing, Canon IJ Status Monitor will be displayed only on the client system.

Note

- Install the printer driver from the Setup CD-ROM that accompanies the printer on the print server system and each of the client systems according to the OS of each system.

Related Topic

➔ [Restrictions on Printer Sharing](#)



[Page top](#) ↑

Advanced Guide

Advanced Guide > Appendix > Sharing the Printer on a Network > Settings on Print Server

Settings on Print Server

To use a printer in a network, set printer sharing on the print server system.

The procedure for setting up the print server systems is as follows:

1. Install the printer driver on the print server system

For details on installation instructions, refer to the "Install the Software" in the manual: Getting Started.

2. Select items from the Start menu as shown below:

- In Windows Vista, select the Start menu -> Control Panel -> Hardware and Sound -> Printers.
- In Windows XP, select the Start menu -> Control Panel -> Printers and Other Hardware -> Printers and Faxes.
- In Windows 2000, select the Start menu -> Settings -> Printers.

The Printers window (Windows Vista, Windows 2000) or Printers and Faxes window (Windows XP) is displayed.

3. Click the icon for the model name of printer to be shared

- In Windows Vista, press the Alt key on your keyboard and then select Run as administrator -> Sharing... from the displayed File menu.
- In Windows XP or Windows 2000, select Sharing... from the File menu.

Note

- Windows XP may display a message recommending the user to use the Network Setup Wizard to set up sharing.
When this message appears, choose not to use the wizard and then set up sharing.

4. Set sharing

Select Share this printer (Windows Vista, Windows XP) or Shared as (Windows 2000) on the Sharing tab to set a shared name as desired, and click OK.

Important

- In Windows Vista, a confirmation/warning dialog box may appear when installing, uninstalling, or starting software.
This dialog box appears when administrative rights are required to perform a task.
If you are logged on to an administrator account, click Continue or Allow to continue.
Some applications require an administrator account to continue. If you are logged on to a standard account, switch to an administrator account, and restart the operation from the beginning.

This completes the setup on the print server system. Next, set up the client systems.



Advanced Guide

Advanced Guide > Appendix > Sharing the Printer on a Network > Settings on Client PC

Settings on Client PC

After setting up the print server system, set up the client system.

The procedure for setting up the client systems is as follows:

In Windows Vista

1. Install the printer driver on the client systems

To install the driver, load the Setup CD-ROM that comes with the printer, and select Custom Install. For details on connection instructions, refer to the "Install the Software" in the manual: Getting Started.

Note

- During the installation, a screen prompting you to turn the printer on appears. Click Manual Selection and then select an appropriate port to complete your installation.

2. Start the wizard

Select the Start menu -> Network -> Add a printer.
The Add Printer window appears.

3. Add a printer

Select Add a network, wireless or Bluetooth printer, and click the icon for the printer that you have configured on the print server system to be shared, and then click Next.

Note

- If the icon for the printer is not displayed, check that the printer is actually connected to the print server.
- It may take some time for the icon for the printer to appear.

4. Complete the setup

Take the appropriate action as described on the screen and then click Finish.
The icon for the shared printer will be created in the Printers window.

This completes the setup on the client systems. You can now share the printer in the network.

In Windows XP/Windows 2000

1. Install the printer driver on the client systems

To install the driver, load the Setup CD-ROM that comes with the printer, and select Custom Install. For details on connection instructions, refer to the "Install the Software" in the manual: Getting Started.

Note

- During the installation, a screen prompting you to turn the printer on appears. Click Manual Selection and then select an appropriate port to complete your installation.

2. Start the wizard

- In Windows XP, select the Start menu -> Control Panel -> Printers and Other Hardware -> Printers and Faxes -> Add a printer.
- In Windows 2000, select the Start menu -> Settings -> Printers -> Add a printer.

When Welcome to the Add Printer Wizard screen appears, click Next.

3. Add a printer

Select A network printer, or a printer attached to another computer (Windows XP) or Network printer (Windows 2000), then click Next.

On the Specify a Printer window (Windows XP) or Locate Your Printer window (Windows 2000), click Next and then search for the print server system.

Click the icon for the printer that you have configured on the print server system to be shared, and then click Next.

Note

- If the icon for the printer is not displayed, check that the printer is actually connected to the print server.
-

4. Complete the setup

Take the appropriate action as described on the screen and then click Finish.

The icon for the shared printer will be created in the Printers and Faxes window (Windows XP) or Printers window (Windows 2000).

This completes the setup on the client systems. You can now share the printer in the network.



Advanced Guide

Advanced Guide > Appendix > Sharing the Printer on a Network > Restrictions on Printer Sharing

Restrictions on Printer Sharing

These are restrictions that apply if you are using a printer in a network environment. Check the restrictions for the environment you are using.

If you are sharing a printer in a network

- A print completion message may be displayed. To disable the message display, follow the procedure below.
 - **In Windows Vista:**

Press the Alt key from the Printers window on the client system. Open Run as administrator -> Server Properties... from the displayed File menu.

Uncheck Show informational notifications for network printers on the Advanced tab, and then restart the computer.
 - **In Windows XP or Windows 2000:**

Open Server Properties from the File menu of the Printer and Faxes window (Windows XP) or the Printers window (Windows 2000) on the print server system.

Uncheck Notify when remote documents are printed on the Advanced tab, and then restart the computer.
- The bi-directional communication function is disabled so that the correct printer status may not be recognized.

If a client user opens the printer driver properties and then clicks OK with the Enable bidirectional support check box on the Ports tab unchecked, the bi-directional function of the printer server system may also be disabled.

In this case, check Enable bidirectional support check box on both the print server system and the client system.
- When you print from a client system, you cannot use Canon IJ Preview.
- If the functions on the Maintenance tab cannot be set properly from a client system, they may be grayed out. In this case, change the settings from the print server.

When you change the settings of the print server, you should delete the icon of the shared printer from the client system, and then specify the shared settings again in the client system.

If the same printer driver is installed in the print server system and the client system as the local printer

- The net crawl function may automatically create a network printer icon on the client system.



Advanced Guide

Advanced Guide > Using Easy-PhotoPrint EX

Easy-PhotoPrint EX

Using Easy-PhotoPrint EX

--- Transforming Your Photos into Creative Works of Art ---

Easy-PhotoPrint EX allows you to create albums, calendars and stickers easily using photos taken with digital cameras.

You can also print borderless photos easily.

Start Easy-PhotoPrint EX



Click Here: [Easy-PhotoPrint EX](#)

Note

- See the section below for details on how to use Easy-PhotoPrint EX.
 - ➔ [Printing with the Bundled Application Software](#)

Create a Personalized Photo Album

Creating a personalized photo album is an easy task if you use Easy-PhotoPrint EX!

All you need to do is select which photos to use, select a layout, then load paper into your printer and print. After you bind the printed sheets, you'll have the one and only album of your memories!



You can change the layout and background, and attach comments to photos.



You can also select the size and orientation.



You can arrange a photo across the left and right pages.

CHECK!

Select a theme (background design) to create a single-themed album.

Decorate Items with Text and Frames

You can add text and frames to photos. Attach a description of the photo in an album, and add a frame to enhance the photo's atmosphere.



CHECK!

Select Album to add text and frames. You cannot decorate photos with Photo Print.

Create a Calendar Using Your Favorite Photos

Create calendars easily with Easy-PhotoPrint EX. Create your own calendar using your favorite photos! It'll be exciting to turn the calendar pages.



You can use all kinds of photos.

You can also create 2-month, 6-month and 12-month calendars.

Create Stickers

Create stickers easily with Easy-PhotoPrint EX!

Create stickers of your favorite photos and share them with your friends!



CHECK!

You can add text to photos.

Advanced Guide

Advanced Guide > About Solution Menu

About Solution Menu

Quick Shortcut!! Solution Menu

Solution Menu is a menu window that provides quick access from your desktop to Canon applications, manuals, and online product information.

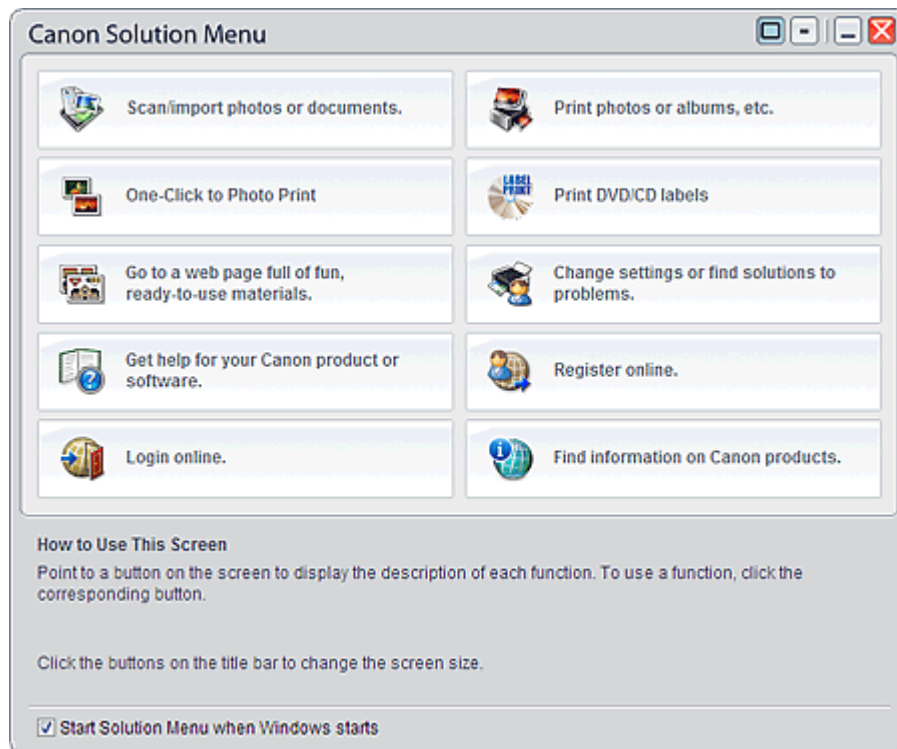

Important

- The number and types of buttons displayed in the window may vary depending on your printer and region.

Starting Solution Menu

 Click Here: [Solution Menu](#)

To start from desktop, see below.

Double-click the Canon Solution Menu icon on the desktop. Alternatively, from the Start menu, select (All) Programs > Canon Utilities > Solution Menu > Solution Menu.



From the next time, Solution Menu starts when Windows starts.

If the Start Solution Menu when Windows starts checkbox at the bottom left of the window is not selected, Solution Menu does not start when Windows starts.

Note

- Solution Menu will start automatically when you install it using the *Setup CD-ROM* that accompanies the printer.

Changing the Window Size

Click  (window size: large) or  (window size: small) on the title bar to change the window size (large or small).

Solution Menu opens with the last used window size next time it is started.

- When screen size is small

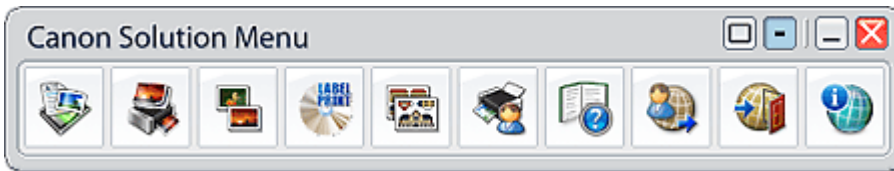

Starting an Application

1. Point to a button on the window to display the description of each application.
2. By clicking each button, the introduced application starts.
Follow the same steps to view the manuals or online product information.

Important

- Internet connection is required to access the online information. Internet connection fees apply.

Exiting Solution Menu

Click  (Close) on the title bar.

Restriction on Use of Solution Menu

This software is subject to the following restriction. Keep this point in mind when using it.

- All icons of the installed applications that support Solution Menu are displayed in the window. After the installation, you cannot rearrange the icons or delete only the icons.

[Page top](#)



Digital Photo Printing Guide

-Printing Techniques to Maximize Your Printer's Performance-

MA-5221-V1.00

❑ Printer-based Digital Photo Printing

This section describes the differences between silver salt film cameras and digital cameras as well as the points to check when printing digital photos.

This section also explains the basics of color management that are essential for printing digital photos.

❑ Printing from Computers

This section first describes the operational flows of printing from computers, points to check in shooting settings on digital cameras, and the points to check in the application settings.

Then, this section explains how to print from Easy-PhotoPrint Pro and from other applications by utilizing your printer's performance.

❑ Adjusting Colors Flexibly on a Digital Camera before Printing

This section explains the advanced functions that can be customized on PictBridge-compatible Canon digital cameras.

❑ Printing in Grayscale

This section explains how to print digital photos in grayscale from Easy-PhotoPrint Pro and from other applications by utilizing your printer's performance.

[Page top](#) 

Printer-based Digital Photo Printing

 [Printing Photos from Digital Photo Data](#)

 [Essential Basics of Color Management](#)

[Page top](#) 

Digital Photo Printing Guide

Canon

[Digital Photo Printing Guide](#) > [Printer-based Digital Photo Printing](#) > [Printing Photos from Digital Photo Data](#)



Printing Photos from Digital Photo Data

Digital photo data can only be transformed into photos after being transferred to a computer and printed using a printer.

Knowledge of color management, that is unnecessary for developing silver salt films, is required for this process.

This section explains the differences between silver salt film cameras and digital cameras as well as the points to check when printing digital photos.

▣ Taking Creative Photos Using Digital Cameras

Technological advances in digital cameras over the last few years have been remarkable.

When digital single-lens reflex cameras were first released, they were only used by professional photographers with extensive knowledge. Today, digital cameras, especially compact models, are popular among many professionals and amateurs thanks to their ease of use and affordable prices.

Why do professionals and amateurs use digital cameras? Here are just some of the major advantages of digital cameras:

- **Large capacity memory cards can be used.**
 - ➔ There are no problems with things like replacing film and rewind failure.
- **Framed images can be checked on the LCD and captured images can be checked on the spot.**
 - ➔ There is no need to wait for images to be developed before seeing the results.
- **Captured images can be printed from computers.**
 - ➔ There is no need to stay in a dark room or to send films away to be developed and printed.
- **Working with a computer leads us into a new world of retouching that allows you to correct exposure, contrast, etc. after capturing images to reproduce the real scenes.**
 - ➔ Users are fairly limited in terms of what can be done with color adjustments in the photo printing process once films have been developed. With digital photo data, you do

not need to have it adjusted/corrected by anyone else since you can edit it yourself on a computer.

In other words, by using a digital camera, you can check and complete all processes from taking the picture to printing it, and you can convert a picture in your mind into reality as you wish. This is one of the major reasons for the popularity of digital cameras.

Points to Check when Printing Photos from Digital Photo Data

Digital photo data is only transformed into works of art after you edit/modify it yourself and print it. When you print digital camera photos from a printer, are the colors really what you wanted?

Complaints about colors such as "The printed colors are different from the colors on the images taken" and "The printed colors do not match the colors on the monitor" can sometimes be heard.

A way of handling color management for printing could be behind such complaints.

Color management, ICC profile and other factors, that are unnecessary for silver salt film cameras, can be keywords for taking all the way through to printing digital photos.

This Digital Photo Printing Guide explains the procedures for using applications as well as keywords and the basics of color management that are essential for maximizing your printer's performance and for creating rewarding photos.

Let's look at the following points.



Check1 Are printed colors the same as the colors shown on the images taken?

"The printed colors are different from the colors shown on the images taken." "The printed colors do not match the colors on the monitor." One cause of such complaints about colors is incorrectly configured color management settings. Follow the link below and learn about the basics of color management and the required environment.

 [Essential Basics of Color Management](#)



Check2 Are the digital camera settings correct?

Print results are affected by camera settings and data type.

Follow the link below to learn more about digital camera settings.

 [Points to Check in the Digital Camera Settings](#)



Check3 Check the operational flow from taking the picture to printing it.

Print settings should be configured according to the application used for editing and the type of data to be printed. Follow the link below to check the application and data that you are using, and to find the settings that best meet your requirements.

 [Overview of Printing from Computers](#)



Check4 Are the application settings correct?

If you open data in an application and print it with an incorrect ICC profile, the printed photo will not be what you want. Follow the link below to learn about the procedures for checking opened data type and for specifying an ICC profile.

[Points to Check in the Application Settings](#)



Check5 Check the printing procedure.

Print settings should be configured according to your application and depending on the purpose of printing such as "I want to print utilizing the color space of the digital photo." Follow the links below to learn about the print settings for your application and that best meet your requirements.

[Printing from Easy-PhotoPrint Pro](#)

[Printing from Other Applications](#)

Next >>

Page top ↑

Digital Photo Printing Guide

Canon

[Digital Photo Printing Guide](#) > [Printer-based Digital Photo Printing](#) > Essential Basics of Color Management



Essential Basics of Color Management

This section explains the basics of color management that will help you maximize your printer's performance and create rewarding work of art (in photographic form).

What is Color Management?

Let's look at the processes involved in printing digital camera photos.

- (1) Capture images with a digital camera.
- (2) Check the image you want to print and its colors on a computer monitor.
- (3) Print it from a printer.

Colors captured with a digital camera, colors that can be displayed on a monitor and colors that can be printed using a printer cannot be reproduced in the same colors when displayed/printed on other devices, due to differences between color spaces supported by each device.

The color management system (color matching) is created to uniformly manage device-dependent colors by using a common color space.

The color management system is generally used to convert each device-dependent color to a common device-independent color space represented by Lab values (defined by lightness, hue and saturation), then to color spaces of other devices. The color management system is built into operating systems under such names as ICM (Windows) and ColorSync (Macintosh).

An ICC (International Color Consortium) profile is required to convert (translate) device-dependent colors to a color space common to Windows and Macintosh.

ICC profiles are compatible with color spaces for devices such as monitors and printers and color spaces for digital photo data. By specifying ICC profiles correctly, you can display/print colors of digital photo data in a common color space.

The flow of color management performed when printing digital photos by using ICC profiles is as follows:

- (1) Captured images are converted to Lab values for a common color space via the input profile for captured images.
- (2) For monitors, the images converted to a common color space are converted to RGB values via the monitor display profile.

(3) For printers, the images converted to a common color space are converted to RGB values via the printer output profile in accordance with the printer driver's characteristics.

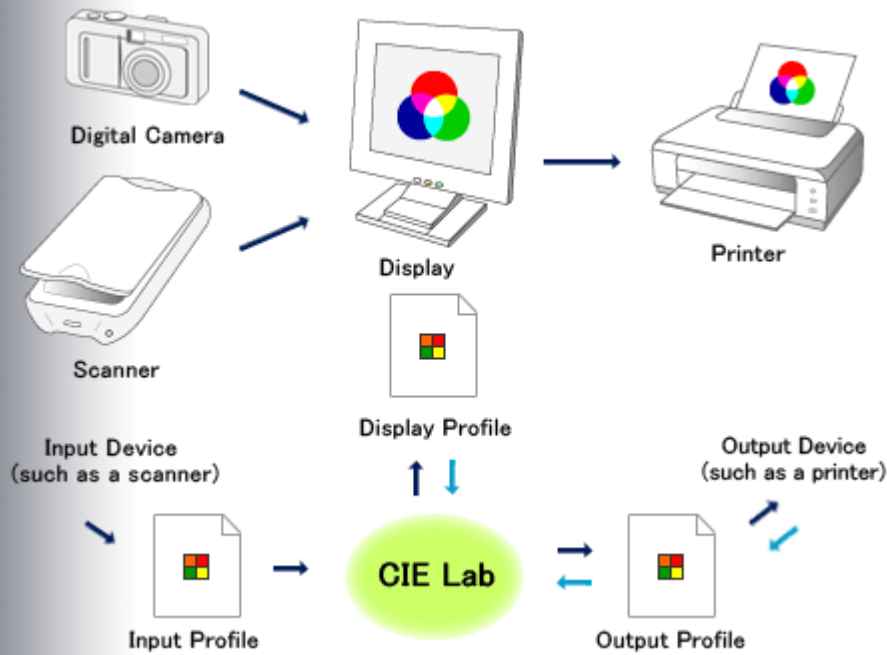

MEMO

- **Are the monitor settings and usage environment appropriate?**

The monitor settings and usage environment are important factors for correct color management. Monitor calibration and ambient lighting are two of the key factors that will affect display of the correct colors. Even if profiles have been set correctly, images may not be displayed in the correct colors depending on the monitor settings and usage environment. Check the following:



Check1 Is the monitor driver or a profile for your monitor installed?

Check Monitors in Device Manager. If standard monitor types or similar or another manufacturer's name appears, download the corresponding monitor driver or profile from the website for your monitor.



Check2 Are you using a fluorescent lamp designed for color evaluation?

Commercially available fluorescent lamps have different color temperatures and cannot be used as light sources to confirm correct colors. To confirm the correct colors on a monitor, it is recommended that you use D50 fluorescent lamps with high color rendering properties that reproduce colors more faithfully.



Check3 Have you calibrated the monitor?

If colors are important to you, you can calibrate the monitor by using a specialized application and measuring device to display the colors that you want. However, this can be very costly.

- **Print according to the lighting in the viewing environment.**

In Windows Vista, you can print using the ambient light correction function if you print from

Easy-PhotoPrint Pro.

Ambient light correction is a function that reduces the differences in the way images appear depending on the place where they are viewed, displayed or exhibited. You can print in color tones suitable for each lighting condition.

■ [Printing According to the Lighting in the Viewing Environment](#)

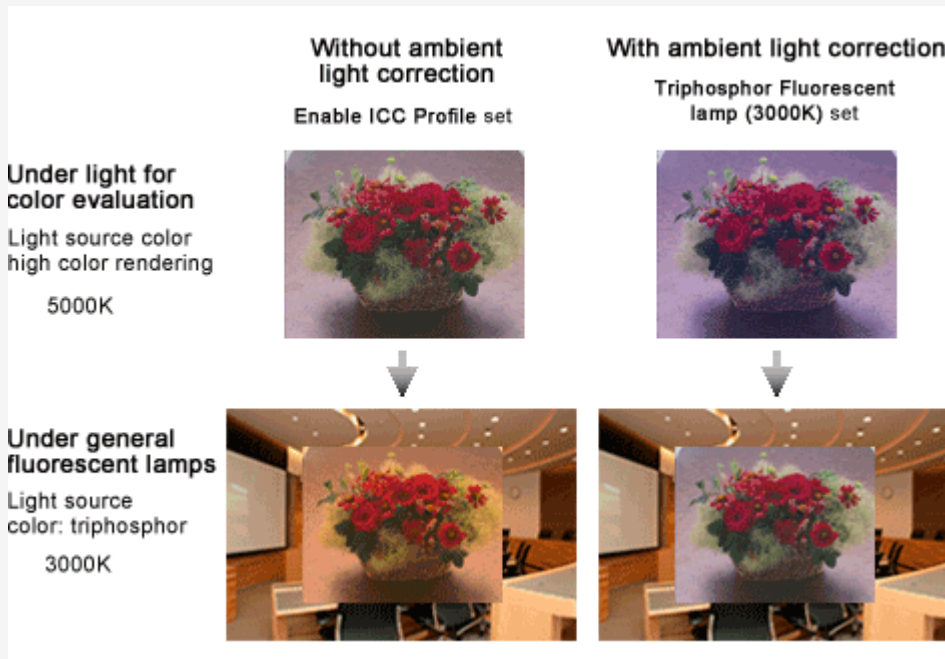

■ **About sRGB and Adobe RGB**

You must consider color spaces when printing digital photos using color management.

As mentioned earlier, an ICC profile is required to convert (translate) each device-dependent color to a common color space. sRGB and Adobe RGB are most often used as common color spaces.

The diagram below shows the ranges of colors that can be represented by digital cameras, natural colors (the visible region), printers, the sRGB color space and the Adobe RGB color space.

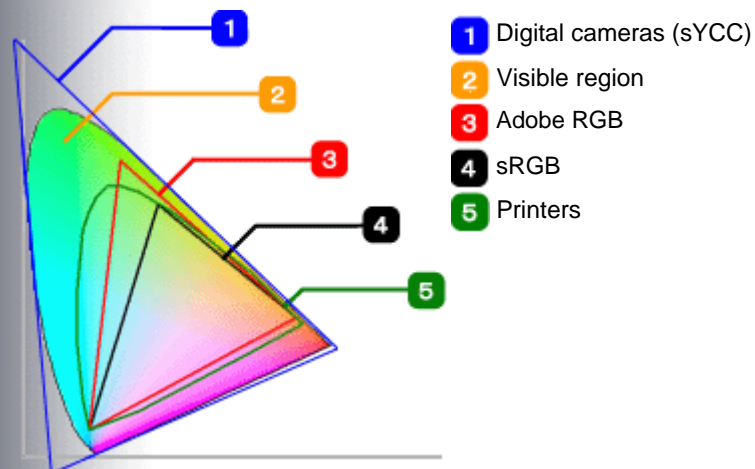

■ **Maximizing Your Printer's Performance in Adobe RGB Color Space**

As shown in the diagram above, the Adobe RGB color space has a wider gamut than sRGB.

This printer's color space also has a wider gamut than sRGB.

This means that the Adobe RGB color space provides a larger color space for printing, which

allows you to maximize your printer's performance.

For example, compare the two photos below. You should be able to tell the color difference between the cobalt blue seas. Color differences are distinct in Adobe RGB when subjects have vivid, highly saturated gamut.



sRGB image



Adobe RGB image

Some digital single-lens reflex cameras support Adobe RGB. If RAW mode is also supported, you can edit/print images using the Adobe RGB color space by processing captured images in Adobe RGB and adding ICC profile tags.

Check the following when printing Adobe RGB images.



Check1 How can I check the colors of Adobe RGB images?

It is impossible to reproduce Adobe RGB colors on computer monitors other than those used by professionals. Before you edit/retouch Adobe RGB images, print them using the Adobe RGB color space and check the colors.

[Printing by Utilizing the Source Color Space \(Printing from Easy-PhotoPrint Pro\)](#)

[Printing by Utilizing the Source Color Space \(Printing from Other Applications\)](#)



Check2 What is RAW data?

RAW data allows you to process images using Adobe RGB and save them with ICC profile tags. Look at the advantages of capturing RAW images.

[Printing Rewarding Photos from RAW Data](#)



Check3 How can I convert sRGB to Adobe RGB?

You can edit sRGB images using the Adobe RGB color space. However, sRGB images will be printed with increased saturation if opened in the Adobe RGB color space directly. They must go through the correct color space conversion process.

[Points to Check in the Application Settings](#)

It is recommended that you print sRGB images using the color correction function of the driver

You would not be aware of color spaces when using a compact digital camera. Generally, compact digital cameras are set to use the sRGB color space.

sRGB is a color space designed to display uniform colors on digital cameras and monitors.

On a monitor, you can check the images in colors as close to the original colors as possible.

Use the color correction function of the driver when printing sRGB images so that you can check edited/retouched images on a monitor and print the resulting images.

In addition, you can print captured images in popular color tones using Canon Digital Photo Color.



Check1 How can I utilize the characteristics of compressed data?

Exif is the standard file format for digital camera images. You can print Exif images captured with a digital camera using the sYCC color space that is larger than the sRGB color space.

[Utilizing Characteristics of Compressed Data](#)



Check2 How can I print sRGB images using the color correction function of the driver?

You can print sRGB images in popular color tones with Canon Digital Photo Color using the color correction function of the driver.

[Printing with Canon's Unique Color Tones \(Printing from Easy-PhotoPrint Pro\)](#)

[Printing with Canon's Unique Color Tones \(Printing from Other Applications\)](#)



Check3 How can I edit/retouch sRGB images and print the resulting images?

You can edit/retouch sRGB images and print the resulting images.

[Edit/Retouch sRGB Images and Print the Resulting Images \(Printing from Easy-PhotoPrint Pro\)](#)

[Edit/Retouch sRGB Images and Print the Resulting Images \(Printing from Other Applications\)](#)

[« Previous](#)

[Page top ↑](#)

Printing from Computers

Overview of Printing from Computers

- Printing from Easy-PhotoPrint Pro
- Printing from Other Applications

Points to Check in the Digital Camera Settings

Points to Check in the Application Settings

Printing from Easy-PhotoPrint Pro

- Case 1 Printing by Utilizing the Source Color Space
- Case 2 Edit/Retouch sRGB Images and Print the Resulting Images
- Case 3 Printing with Canon's Unique Color Tones
- Case 4 Printing According to the Lighting in the Viewing Environment

Printing from Other Applications

- Case 1 Printing by Utilizing the Source Color Space
- Case 2 Printing by Specifying an ICC Profile within the Application
- Case 3 Printing from Applications in which ICC Profiles Cannot be Set
- Case 4 Edit/Retouch sRGB Images and Print the Resulting Images
- Case 5 Printing with Canon's Unique Color Tones

Digital Photo Printing Guide



[Digital Photo Printing Guide](#) > [Printing from Computers](#) > Overview of Printing from Computers



Overview of Printing from Computers

This section explains the operational flows of printing from computers. Follow the procedure based on your application, image type and how you want to print.

Which application do you want to print from?

Digital photo printing settings/operations vary for each application. Select a type of application below and follow the procedure shown.

Print from Easy-PhotoPrint Pro

Check this flow when you want to print digital camera photos from Easy-PhotoPrint Pro, an application supplied with this printer, after opening (then editing/retouching) them in Adobe Photoshop CS/Adobe Photoshop CS2/Adobe Photoshop CS3/Adobe Photoshop Elements 6 or Digital Photo Professional.

You can easily print using the color management system when printing from Easy-PhotoPrint Pro via Adobe Photoshop CS/Adobe Photoshop CS2/Adobe Photoshop CS3/Adobe Photoshop Elements 6 or Digital Photo Professional.

[Printing from Easy-PhotoPrint Pro](#)

Print from Other Applications Specifying an ICC Profile within the Application

Check this flow when you want to open (then edit/retouch) a digital camera photo in an application other than Easy-PhotoPrint Pro (such as Adobe Photoshop or an application supplied with a digital camera) and print it by specifying an ICC profile within the application.

[Printing from Other Applications \(Specifying an ICC Profile within the Application\)](#)

Print from Other Applications Specifying an ICC Profile in the Driver

Check this flow when you want to start the printing process from an application in which ICC profiles cannot be set (such as an application for simple photo printing), and specify an ICC profile in the Print Settings screen of the driver.

[Printing from Other Applications \(Specifying an ICC Profile in the Driver\)](#)

Next 

Page top 

 Which application do you want to print from?

 **Printing from Easy-PhotoPrint Pro**

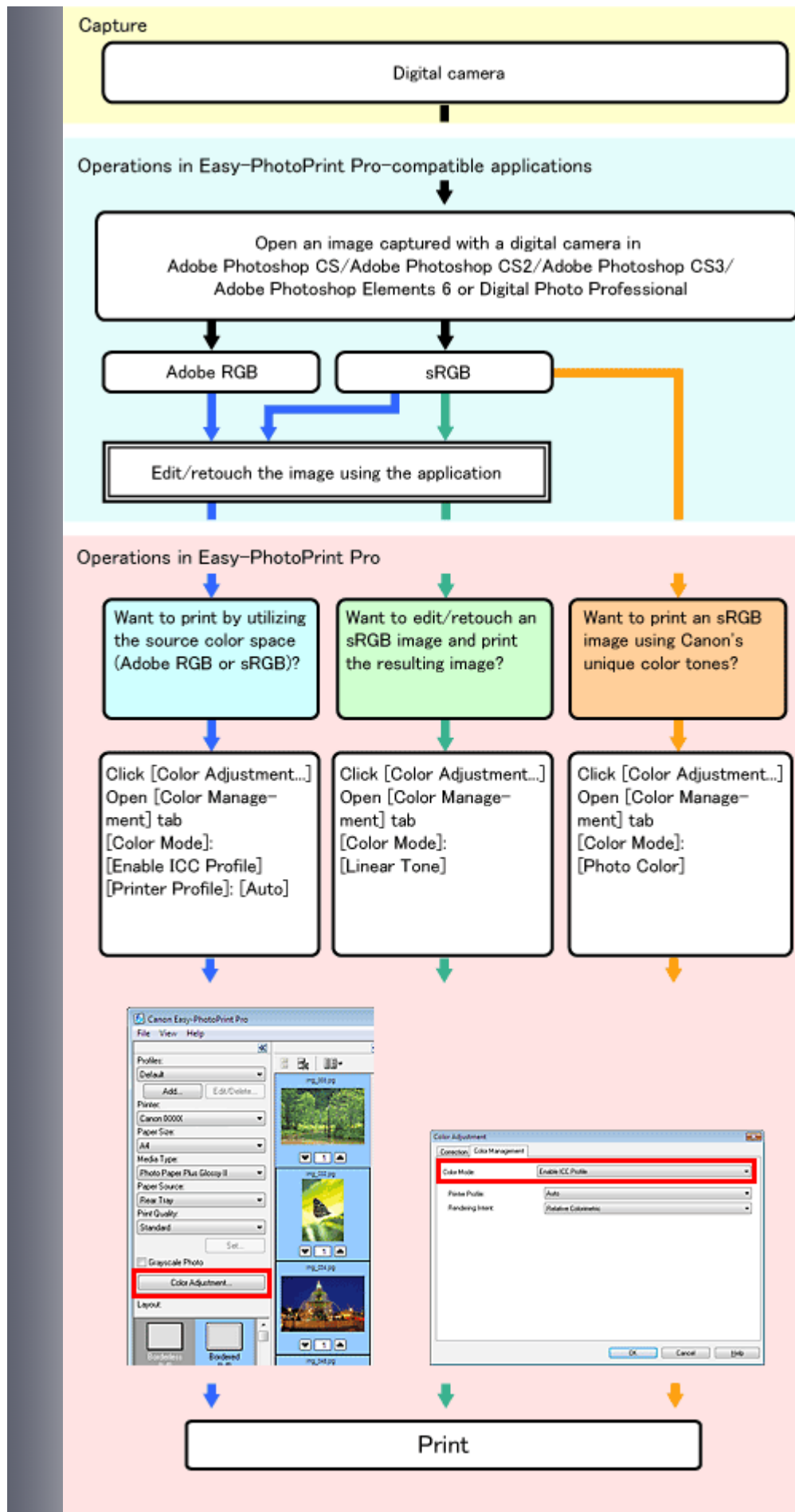

Detailed Operations

 When you want to print by utilizing the color space of the source ICC profile (Adobe RGB or sRGB)

 [Printing from Easy-PhotoPrint Pro \(Printing by Utilizing the Source Color Space\)](#)

When you want to edit/retouch sRGB images in Adobe Photoshop CS/Adobe Photoshop CS2/Adobe Photoshop CS3/Adobe Photoshop Elements 6 or Digital Photo Professional and print the resulting images

 [Printing from Easy-PhotoPrint Pro \(Edit/Retouch sRGB Images and Print the Resulting Images\)](#)

When you want to print sRGB images in popular color tones using Canon Digital Photo Color

 [Printing from Easy-PhotoPrint Pro \(Printing with Canon's Unique Color Tones\)](#)**MEMO**

- In Windows Vista, you can print using the ambient light correction function if you print from Easy-PhotoPrint Pro.

 [Printing According to the Lighting in the Viewing Environment](#)[« Previous](#)[Next »](#)[Page top ↑](#)

 Which application do you want to print from?

Printing from Other Applications

Specifying an ICC Profile within the Application

Capture



Operations in applications

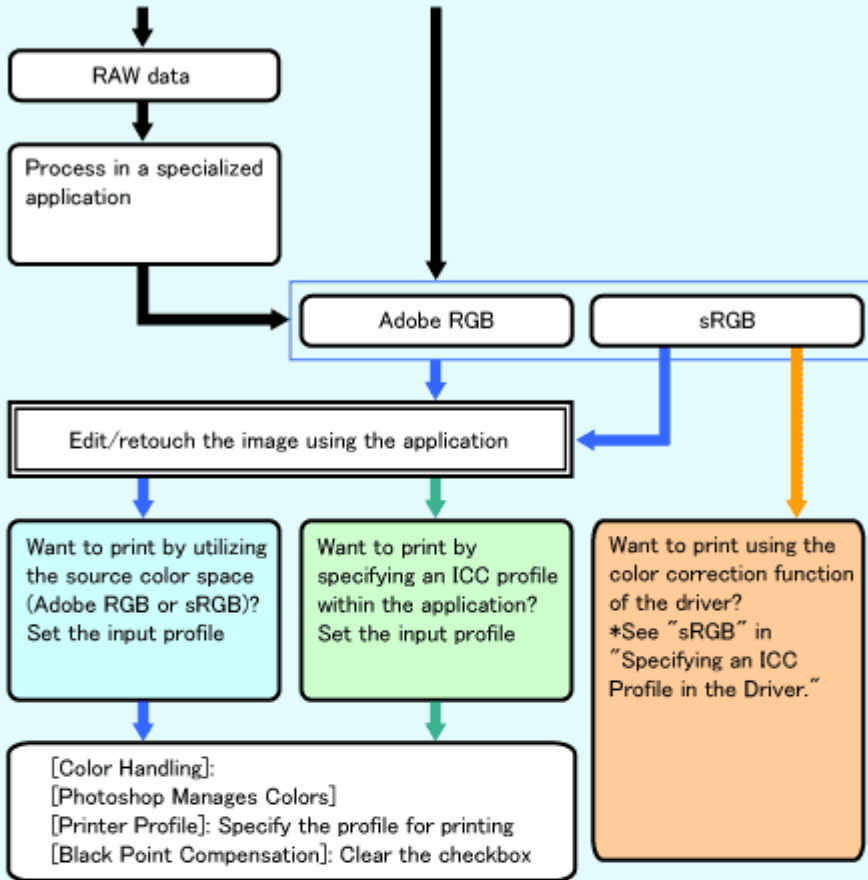

Printer driver settings

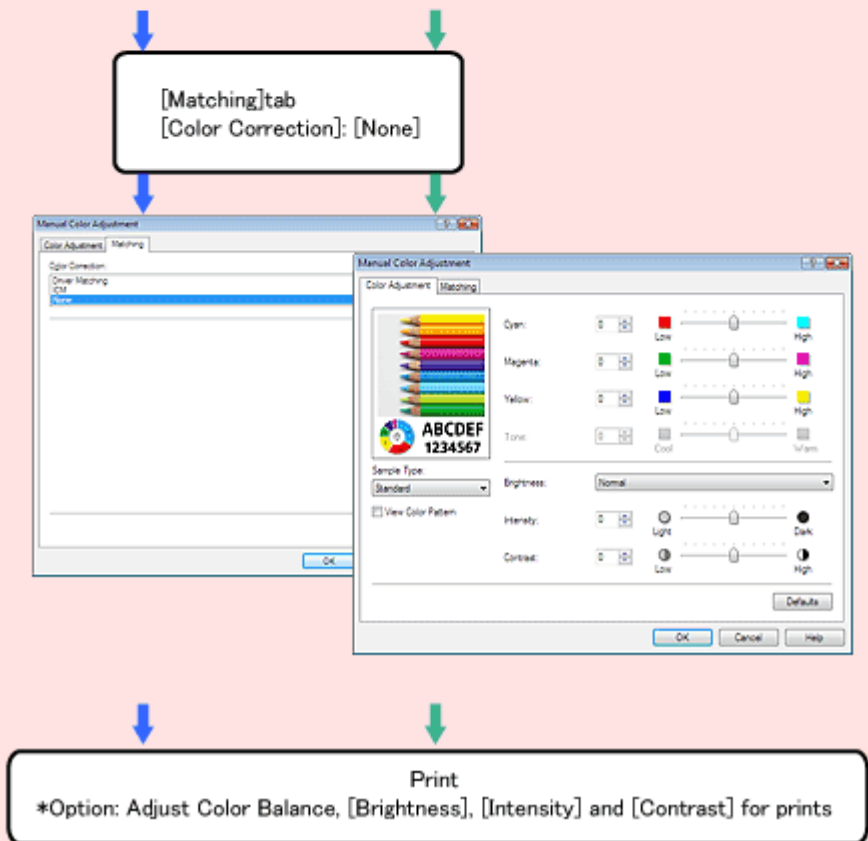

Detailed Operations



When you want to print by utilizing the color space of the source ICC profile (Adobe RGB or sRGB)

 [Printing from Easy-PhotoPrint Pro \(Printing by Utilizing the Source Color Space\)](#)





When you want to print edited/retouched images by specifying a profile

 [Printing from Other Applications \(Printing by Specifying an ICC Profile within the Application\)](#)

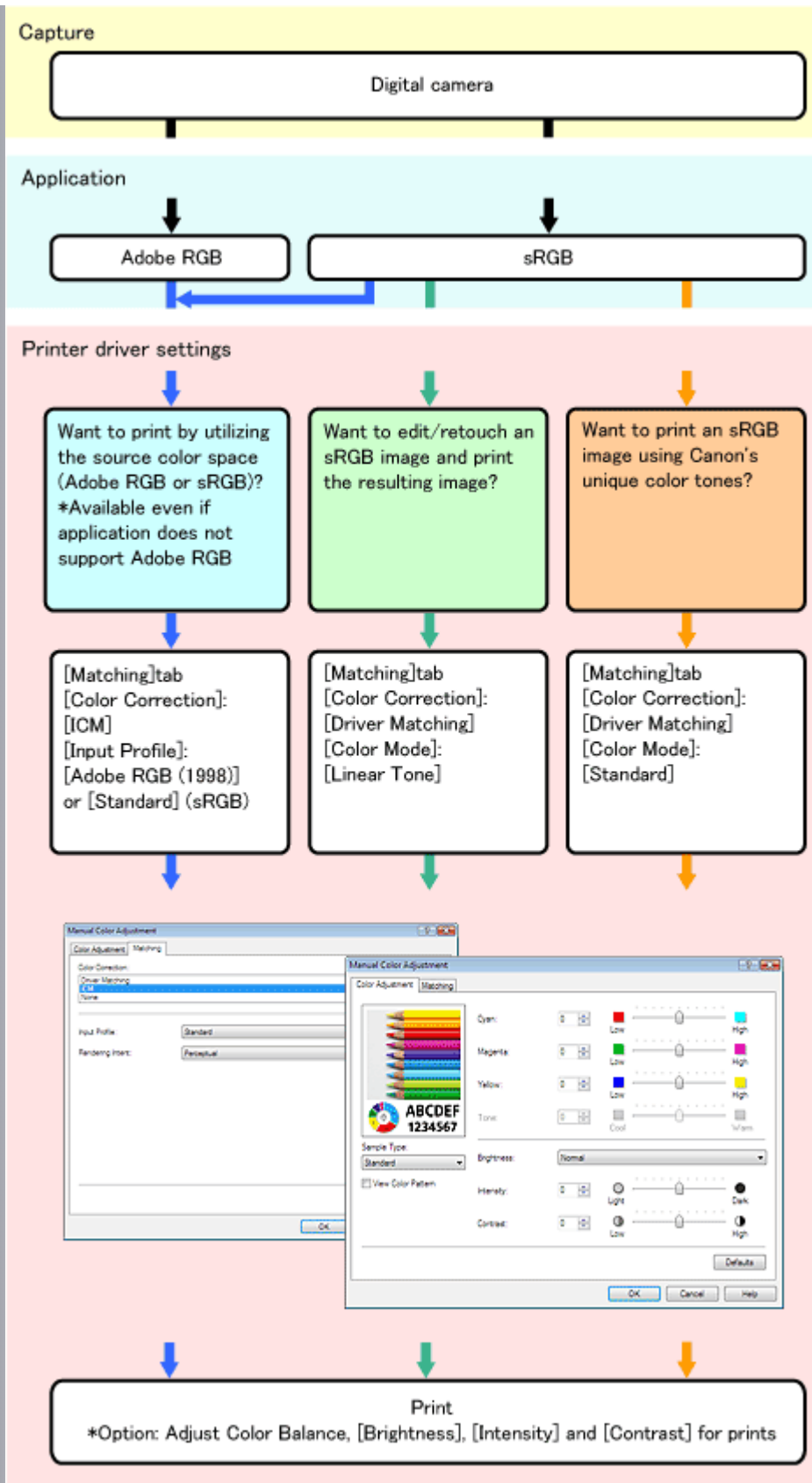
Specifying an ICC Profile in the Driver



Detailed Operations

-  When you print by utilizing the color space of the source ICC profile (Adobe RGB or sRGB)
-  Printing from Other Applications (Printing from Applications in which ICC Profiles Cannot be Set)
-  When you want to edit/retouch sRGB images and print the resulting images

 [Printing from Other Applications \(Edit/Retouch sRGB Images and Print the Resulting Images\)](#)

 When you want to print sRGB images in popular color tones using Canon Digital Photo Color

 [Printing from Other Applications \(Printing with Canon's Unique Color Tones\)](#)

 [Previous](#)

[Next](#) 

[Page top](#) 

Digital Photo Printing Guide



[Digital Photo Printing Guide](#) > [Printing from Computers](#) > Points to Check in the Digital Camera Settings



Points to Check in the Digital Camera Settings

This section explains shooting settings on digital cameras and differences in print results by data type.

✚ Digital Camera Settings

When you capture images with a digital camera, the image quality is significantly affected by the number of recorded pixels (image size) and the compression rate.

Recorded pixels (image size) refer to the number of pixels comprising an image recorded on a memory card or other digital media. The higher the value, the higher the resolution and the better the quality of the image.

However, higher value of the recorded pixels means larger file size and more time spent saving captured images. Note that if the number of pixels is set to high, you may miss an opportunity to capture an important moment during sports photography, for example, where continuous shooting is required.

The compression rate is the rate used to compress image data in JPEG format. With Canon digital cameras, the compression rate increases depending whether you use SuperFine, Fine, or Normal. The higher the compression rate, the smaller the file size.

The compression rate also affects the image quality. When the compression rate is increased, noise caused by tonal variation tends to appear. Many of these noises show up in landscape photos in which colors of similar tones, such as the blue of the sky and the green of the trees, are likely to occur. It is recommended that you set the compression rate to low (by selecting SuperFine) when capturing landscape images.

In other words, you can capture the highest quality images by setting the recorded pixels to the maximum and by setting the compression rate to the minimum. However, the file size will increase.

When setting the recorded pixels (image size) and the compression rate, it is important to be aware of the purpose of printing photos, the paper size and the image quality you want.

When printing on 4" x 6" (10 x 15 cm) size paper, select 1600 x 1200 pixels for the best results.

See the table below to set the number of recorded pixels for the paper on which you are printing.

Recorded Pixels (Image Size) & Corresponding Paper Sizes

Recorded Pixels (Image Size)	Paper Size

3600 x 2400 (approx. 8.6 megapixels)	A3/Legal or larger
3456 x 2304 (approx. 8.0 megapixels)	
3072 x 2304 (approx. 7.0 megapixels)	A3/Legal
3072 x 2048 (approx. 6.3 megapixels)	From A4/Letter to sizes smaller than A3/Legal
2592 x 1944 (approx. 5.0 megapixels)	
2496 x 1664 (approx. 4.15 megapixels)	From 5" x 7" (13 x 18 cm) to A4/Letter
2048 x 1536 (approx. 3.1 megapixels)	
2048 x 1360 (approx. 2.8 megapixels)	5" x 7" (13 x 18 cm)
1728 x 1152 (approx. 2.0 megapixels)	
1600 x 1200 (approx. 1.9 megapixels)	4" x 6" (10 x 15 cm)
1536 x 1024 (approx. 1.6 megapixels)	

■ Printing Rewarding Photos from RAW Data

Although it is more usual to compress and save captured images in JPEG format, some digital cameras allow you to capture images in RAW format.

RAW is a file format designed for computer-based image processing. RAW is supported not only by digital single-lens reflex cameras but also by some compact digital cameras, and it is quite common for many professionals and amateurs to capture images in RAW format.

RAW images cannot be printed from photo printing applications in most cases, and an image processing application is required to adjust white balance, contrast, etc. In addition, RAW images are larger in terms of the number of recorded pixels than images captured in other formats.

Then why is RAW used to capture images when it requires image processing and increases the file size?

These are the advantages of capturing images in RAW format.

- (1) While compressed data continues to degrade after being corrected on a computer, RAW data shows almost no degradation.
- (2) You can adjust images captured with incorrect exposure, contrast, etc. when processing them on a computer to match the real scenes.

These two characteristics, no degradation from corrections and the ability to adjust on a computer to match the real scenes, have made it possible to transform pictures in your mind into actual images as you wish. This is the main reason for the use of RAW.

It is recommended that you capture images according to your own requirements. For example, capture snapshots as compressed data and capture photos for an exhibition in RAW format to be able to adjust them to your satisfaction.

■ Processing RAW Images for Adjustments



Check1 Adjust the white balance

You can adjust the white balance when processing RAW images with a specialized application.

Source RAW image

After white balance adjustment



Check2 Adjust the contrast

You can change gradations of captured images. Increase or decrease contrast to change their impressions.

Source RAW image



After contrast adjustment



Utilizing Characteristics of Compressed Data

Images captured with a digital camera are normally compressed and saved in JPEG format. Some photo printing applications only support JPEG format.

An advantage of compressed images is that you can process and print them from various photo printing applications. In addition, compression of images allows you to reduce the file size and to save more photos on a memory card.

However, you need to be aware that noise tends to appear when the compression rate is increased and that the data degrades after being processed repeatedly.

Exif Print allows you to print by utilizing the information embedded in images captured with a digital camera. Exif 2.2 images captured with a digital camera appear in the sRGB color space when opened in an application, but are saved in the sYCC color space that is larger than the sRGB color space.

Therefore, by utilizing the sYCC color space, you can print Exif 2.2 images in a larger color space than the sRGB color space.

You can print by utilizing the information embedded in images captured with a digital camera using Easy-PhotoPrint EX supplied with this printer.

>> For details, refer to "Using Easy-PhotoPrint EX" in the On-screen Manual:

Advanced Guide.

◀ Previous

Next ▶▶

Page top ▲



Points to Check in the Application Settings

This section explains the points to check and the procedures in applications when specifying ICC profiles in applications other than Easy-PhotoPrint Pro, using Adobe Photoshop CS3 as an example.

✚ Checking the Application Settings

After opening an image captured with a digital camera in an application in which ICC profiles can be set, you will need to check the input status of the image and also check that the ICC profile setting is correct before printing.

Follow these steps to check.

1. Checking the Image Data

- (1) Check whether the image is in Adobe RGB, sRGB or has no ICC profile.

For example, in Adobe Photoshop, select Print from the File menu. Image data information appears next to Document under Print in the Color Management screen.

- (2) If sRGB appears for an Adobe RGB image or vice versa, check the assigned ICC profile.

Also, check that you have not converted the color space when opening the image. You can assign the source ICC profile when selecting Convert to Profile from the Edit menu.

2. Setting the ICC Profile for Printing

Set the profile you want to use for printing.

For example, in Adobe Photoshop, select Print from the File menu, and specify a profile from Color Handling under Options in the Color Management screen.

▶ Printing in Adobe RGB or sRGB Color Space

When you want to print an Adobe RGB or sRGB image in the input profile color space, check that the input profile is set to Adobe RGB or sRGB, select the item that allows the application to manage colors, then specify a profile for printing.

For example, in Adobe Photoshop, select Photoshop Manages Colors for Color Handling, and specify the profile of the paper you want to print on in Printer Profile.

At this time, please clear the Black Point Compensation checkbox.

For printer settings, see the following section.

[Printing from Other Applications \(Printing by Utilizing the Source Color Space\)](#)

▶ **When the ICC Profile is Not Embedded, or when Printing sRGB Images Using the Driver's Color Correction Function**

Select the item that allows the printer to manage colors.

For example, in Adobe Photoshop, select Printer Manages Colors for Color Handling.

For printer settings, see the following sections.

[Printing from Other Applications \(Edit/Retouch sRGB Images and Print the Resulting Images\)](#)

[Printing from Other Applications \(Printing with Canon's Unique Color Tones\)](#)

▶ **Printing with a Specific ICC Profile**

When you want to specify a custom profile, check that an input profile is set, select the item that allows the application to manage colors, then specify the custom profile.

For example, in Adobe Photoshop, select Photoshop Manages Colors for Color Handling, and specify the custom profile in Printer Profile.

At this time, please clear the Black Point Compensation checkbox.

memo

- When you need to specify the printer profile, select the ICC profile for the paper to print on.

The ICC profiles installed for this printer appear as follows.

Canon XXXXX PR 1
 (1) (2) (3)

(1) Printer model name

(2) Media type

Each pair of letters represents its respective media type:

PR: Photo Paper Pro II

PT: Photo Paper Pro Platinum

GL: Photo Paper Plus Glossy II

MP: Matte Photo Paper

SG: Photo Paper Plus Semi-gloss

(3) Print quality

The numbers correspond to the numbers on the print quality slider in the Set Print Quality dialog box opened from the Print Quality tab of the driver.

The lower the number, the finer the quality.

For printer settings, see the following section.

[Printing from Other Applications \(Printing by Specifying an ICC Profile within the Application\)](#)

 **MEMO**

- **Editing sRGB Images in Adobe RGB Color Space**

Follow these steps to edit/retouch an sRGB image in the Adobe RGB color space. You can edit/retouch in the Adobe RGB color space while preserving sRGB data colors.

(1) Set the working space to Adobe RGB.

Select Color Settings from the Edit menu, then set Working Spaces to Adobe RGB.

(2) In the Assign Profile window, set the profile to sRGB.

Select Assign Profile from the Edit menu, then set Profile to sRGB.

(3) In the Convert to Profile window, set to convert to Adobe RGB.

Select Convert to Profile from the Edit menu, then set Profile under Destination Space to Adobe RGB.

Note: If a profile mismatch error appears when opening a new sRGB image after step (1), select Convert document's colors to the working space.

 Previous

Next 

Page top 

Digital Photo Printing Guide



Digital Photo Printing Guide > Printing from Computers > Printing from Easy-PhotoPrint Pro



Printing from Easy-PhotoPrint Pro

This section explains how to print digital camera photos using Easy-PhotoPrint Pro, an application supplied with this printer, after opening (then editing/retouching) them in Adobe Photoshop CS/Adobe Photoshop CS2/Adobe Photoshop CS3/Adobe Photoshop Elements 6 or Digital Photo Professional.

MEMO

- Easy-PhotoPrint Pro can only be started after installing Easy-PhotoPrint Pro supplied with this printer on a computer on which Adobe Photoshop CS/Adobe Photoshop CS2/Adobe Photoshop CS3/Adobe Photoshop Elements 6 or Digital Photo Professional is installed.

For updated compatibility, visit our website.

>> For details, refer to "Using Easy-PhotoPrint Pro" in the On-screen Manual:

Advanced Guide.

- Using the XPS printer driver enables you to print in the High Dynamic Range (full 16-bit workflow).

>> For details, refer to "Using Easy-PhotoPrint Pro" in the On-screen Manual:

Advanced Guide.

Printing from Easy-PhotoPrint Pro

Case 1 Printing by Utilizing the Source Color Space

- Source image: Adobe RGB or sRGB
- Print result: Image printed using an ICC profile

Case 2 Edit/Retouch sRGB Images and Print the Resulting Images

- Source image: sRGB
- Print result: Resulting image (edited/retouched sRGB image) printed

Case 3 Printing with Canon's Unique Color Tones

- Source image: sRGB
- Print result: sRGB image printed using Canon Digital Photo Color

Case 4 Printing According to the Lighting in the Viewing Environment

- Source image: Adobe RGB or sRGB
- Print result: Image printed according to the selected lighting condition (appearance difference reduced)

[« Previous](#)

[Next »](#)

[Page top ↑](#)

Digital Photo Printing Guide



Digital Photo Printing Guide > Printing from Computers > Printing from Easy-PhotoPrint Pro > Case 1
Printing by Utilizing the Source Color Space

Case 1 Printing by Utilizing the Source Color Space

Edit/retouch an image in an Easy-PhotoPrint Pro-compatible application and print it by utilizing the color space (Adobe RGB or sRGB) supported by the input ICC profile.



Advice

Follow these steps to print images whose input ICC profile is Adobe RGB in the Adobe RGB color space.

1. Starting Easy-PhotoPrint Pro

- (1) Open the image you want to print in an Easy-PhotoPrint Pro-compatible application.

Edit/retouch the image as needed.

memo

- When printing to check the color tone of an Adobe RGB image, open it in an Easy-PhotoPrint Pro-compatible application, then proceed to the next step.

- (2) In Adobe Photoshop, click File > Automate > Easy-PhotoPrint Pro....

Easy-PhotoPrint Pro starts, and the image displayed in Adobe Photoshop appears in Easy-PhotoPrint Pro.

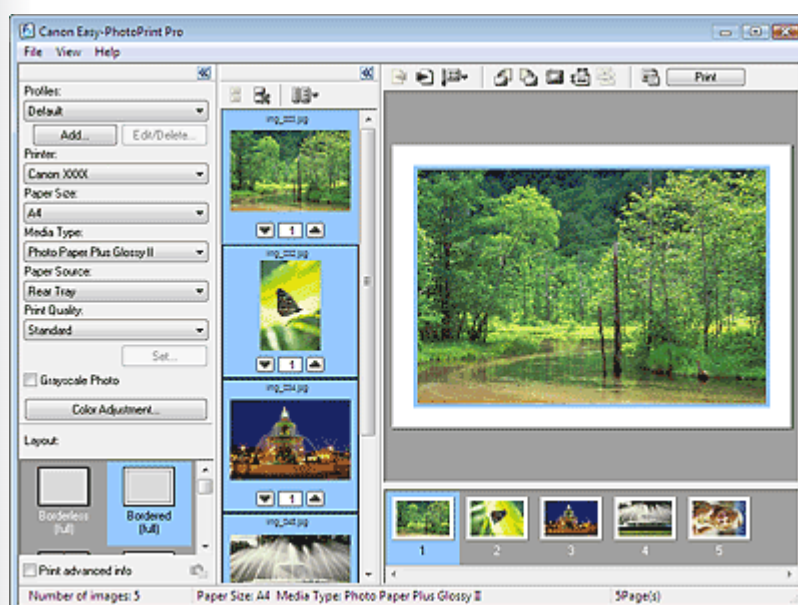

MEMO

- In Digital Photo Professional, click File > Plug-in printing > Print with Easy-PhotoPrint Pro to start Easy-PhotoPrint Pro.

2. Opening the Color Adjustment Dialog Box

(1) Select the image for which you want to adjust the color from the Page List area.

(2) In the Printer Settings window, click Color Adjustment....

The Color Adjustment dialog box appears.

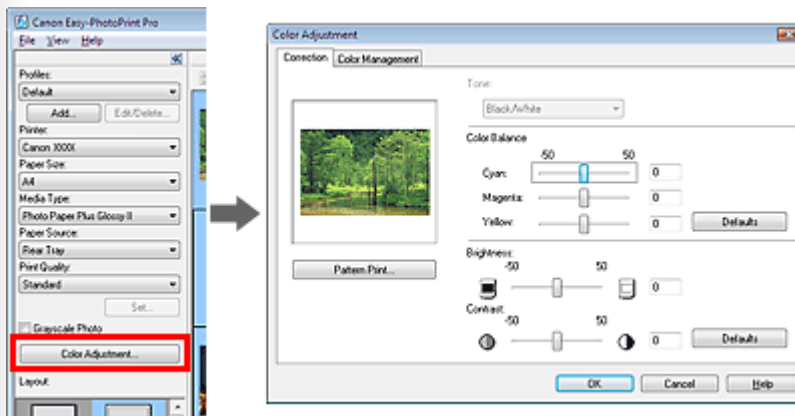

3. Setting the Color Mode and Printer Profile

(1) Click the Color Management tab.

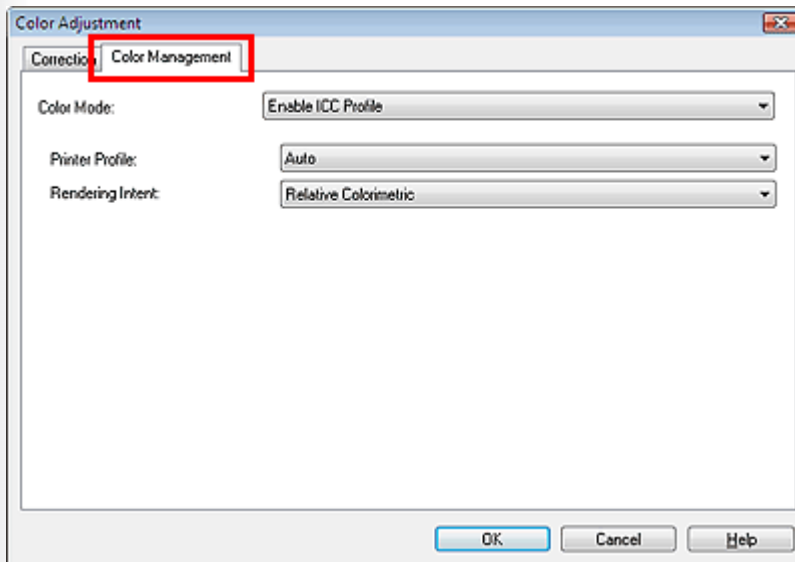

(2) Select Enable ICC Profile for Color Mode.

(3) Select Auto for Printer Profile.

memo

- You can also print with a specific profile by selecting one from the list.

Normally select Auto. If a new ICC profile for Canon brand paper is added, download it and select it from the list.

☒ Checking the Application Settings

(4) Select a method for Rendering Intent and click OK.

4. Printing

(1) Set the Paper Size, Media Type and Layout.

(2) Click Print.

 **MEMO**

- For details on printing procedures and other settings, refer to "Using Easy-PhotoPrint Pro" in the On-screen Manual: *Advanced Guide*.

[« Previous](#)

[Next »](#)

[Page top ↑](#)

Case 2 Edit/Retouch sRGB Images and Print the Resulting Images

Edit/retouch an sRGB image in an Easy-PhotoPrint Pro-compatible application and print the resulting image.



Advice

Apply Linear Tone to output the subtle color differences between the dark and bright parts without changing the brightness of the darkest (blackest) and brightest (whitest) parts. For example, by applying this effect, you can print a photo of blue sky and shadows without losing the details in the shadowy parts. You can also edit/retouch the image and print the resulting image.

1. Starting Easy-PhotoPrint Pro

- (1) Open the image you want to print in an Easy-PhotoPrint Pro-compatible application.

Edit/retouch the image as needed.

- (2) Start Easy-PhotoPrint Pro.

memo

- To start Easy-PhotoPrint Pro, see the following section.

[Starting Easy-PhotoPrint Pro](#)

2. Opening the Color Adjustment Dialog Box

- (1) Select the image for which you want to adjust the color from the Page List area.

- (2) In the Printer Settings window, click Color Adjustment....

The Color Adjustment dialog box appears.

3. Setting the Color Mode

- (1) Click the Color Management tab.

- (2) Select Linear Tone for Color Mode.

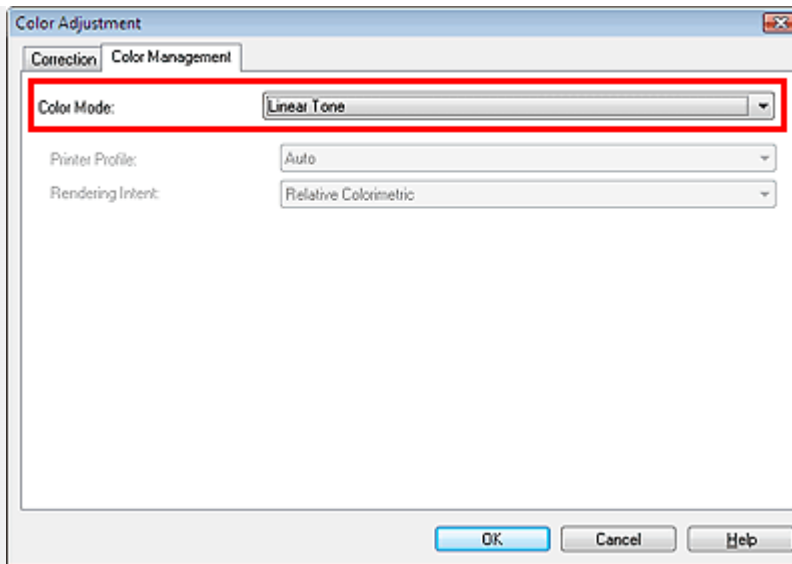

(3) Click OK.

4. Printing

(1) Set the Paper Size, Media Type and Layout.

(2) Click Print.

MEMO

- For details on printing procedures and other settings, refer to "Using Easy-PhotoPrint Pro" in the On-screen Manual: *Advanced Guide*.

[« Previous](#)

[Next »](#)

[Page top ↑](#)

Digital Photo Printing Guide



[Digital Photo Printing Guide](#) > [Printing from Computers](#) > [Printing from Easy-PhotoPrint Pro](#) > Case 3
Printing with Canon's Unique Color Tones

Case 3 Printing with Canon's Unique Color Tones

Print sRGB images using Canon Digital Photo Color.



Advice

Canon Digital Photo Color allows you to print images in popular, beautiful color tones. This is achieved by producing high contrast with sharp, three-dimensional feel while reproducing the genuine colors of the original image.

1. Starting Easy-PhotoPrint Pro

(1) Open the image you want to print in an Easy-PhotoPrint Pro-compatible application.

(2) Start Easy-PhotoPrint Pro.

memo

- To start Easy-PhotoPrint Pro, see the following section.

[Starting Easy-PhotoPrint Pro](#)

2. Opening the Color Adjustment Dialog Box

(1) Select the image for which you want to adjust the color from the Page List area.

(2) In the Printer Settings window, click Color Adjustment....

The Color Adjustment dialog box appears.

3. Setting the Color Mode

(1) Click the Color Management tab.

(2) Select Photo Color for Color Mode.

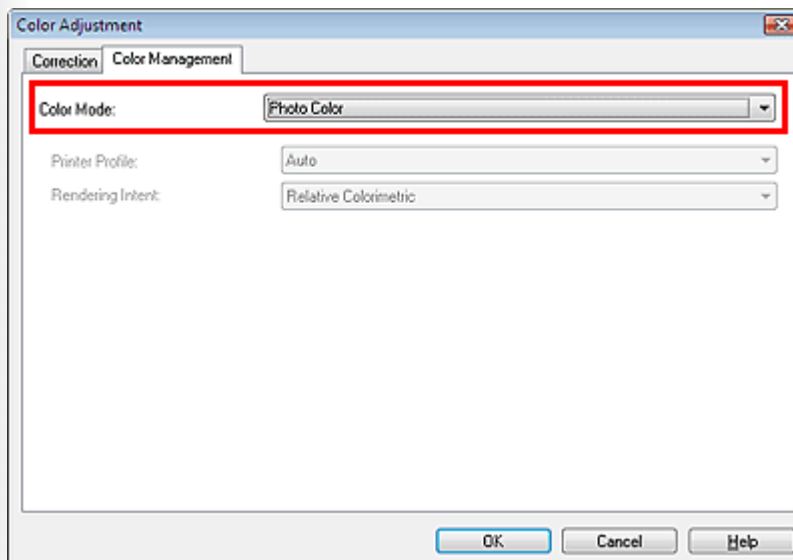

(3) Click OK.

4. Printing

(1) Set the Paper Size, Media Type and Layout.

(2) Click Print.

MEMO

- For details on printing procedures and other settings, refer to "Using Easy-PhotoPrint Pro" in the On-screen Manual: *Advanced Guide*.

[« Previous](#)

[Next »](#)

[Page top ↑](#)

Case 4 Printing According to the Lighting in the Viewing Environment

In Windows Vista, you can print using the ambient light correction function if you print from Easy-PhotoPrint Pro.



Advice

Ambient light correction is a function that reduces the differences in the way images appear depending on the place where they are viewed, displayed or exhibited. You can print in color tones suitable for each lighting condition.

It is recommended that you print an image with different ambient light correction settings to find the color tone suitable for the place where it is viewed, displayed or exhibited.

 [Color appearance examples \(Essential Basics of Color Management\)](#)

1. Starting Easy-PhotoPrint Pro

- (1) Open the image you want to print in an Easy-PhotoPrint Pro-compatible application.

Edit/retouch the image as needed.

- (2) Start Easy-PhotoPrint Pro.

memo

- To start Easy-PhotoPrint Pro, see the following section.

 [Starting Easy-PhotoPrint Pro](#)

2. Opening the Color Adjustment Dialog Box

- (1) Select the image for which you want to adjust the color from the Page List area.

- (2) In the Printer Settings window, click Color Adjustment....

The Color Adjustment dialog box appears.

3. Setting the Color Mode

- (1) Click the Color Management tab.
- (2) Select Ambient Light Correction for Color Mode.
- (3) From Ambient Light, select the lighting condition of the place where the image is viewed, displayed or exhibited.

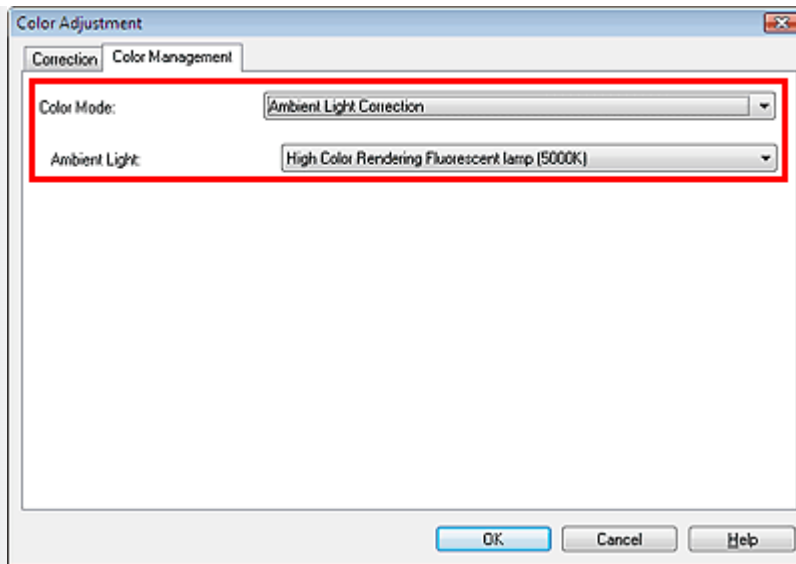

(4) Click OK.

MEMO

- The selectable ambient lighting options include fluorescent lamps designed for color evaluation and other commercially available ones.

For how to check the type of fluorescent lamp and details on the settings, refer to "Using Easy-PhotoPrint Pro" in the On-screen Manual:

Advanced Guide.

4. Printing

(1) Set the Paper Size, Media Type and Layout.

(2) Click Print.

MEMO

- For details on printing procedures and other settings, refer to "Using Easy-PhotoPrint Pro" in the On-screen Manual: *Advanced Guide.*

 Previous

Next 

Page top 



Printing from Other Applications

This section explains how to print images from applications other than Easy-PhotoPrint Pro in Windows Vista.

MEMO

- Using the XPS printer driver enables you to print in the High Dynamic Range (full 16-bit workflow) from Windows Vista Photo Gallery.
> > For details, refer to "XPS Printer Driver" in the On-screen Manual:
Advanced Guide.

Printing from Other Applications

Case 1 Printing by Utilizing the Source Color Space

- Source image: Adobe RGB or sRGB
- Application: Applications in which ICC profiles can be set
- Print result: Image printed according to an input profile using a profile for printing specified within an application

Case 2 Printing by Specifying an ICC Profile within the Application

- Source image: Adobe RGB or sRGB
- Application: Applications in which ICC profiles can be set
- Print result: Image printed according to an input profile using a profile for printing specified within an application

Case 3 Printing from Applications in which ICC Profiles Cannot be Set

- Source image: Adobe RGB or sRGB
- Application: Applications in which ICC profiles cannot be set
- Print result: Image printed in the source color space (Adobe RGB or sRGB)

Case 4 Edit/Retouch sRGB Images and Print the Resulting Images

- Source image: sRGB
- Application: Applications in which ICC profiles can/cannot be set

- Print result: Resulting image (edited/retouched sRGB image) printed

Case 5 Printing with Canon's Unique Color Tones

- Source image: sRGB
- Application: Applications in which ICC profiles can/cannot be set
- Print result: sRGB image printed using Canon Digital Photo Color

[« Previous](#)

[Next »](#)

[Page top ↑](#)

Case 1 Printing by Utilizing the Source Color Space

Print an edited/retouched image by utilizing the color space (Adobe RGB or sRGB) supported by the input ICC profile from an application other than Easy-PhotoPrint Pro in which input ICC profiles can be identified/set.

1. Specifying an ICC Profile within an Application

- (1) Open the image you want to print in an application other than Easy-PhotoPrint Pro.

Edit/retouch the image as needed.

- (2) Check that the correct ICC profile has been assigned, select the item that allows the application to manage colors, then specify the profile for printing.

For example, in Adobe Photoshop, select Photoshop Manages Colors, and specify the profile of the paper you want to print on in Printer Profile.

At this time, please clear the Black Point Compensation checkbox.

memo

- For application settings, see the following section.

[☑-Checking the Application Settings](#)

2. Opening the Print Settings Screen of the Printer Driver

- (1) Select the Print command from the application menu.

Example: Click File > Print....

The Print dialog box appears.

- (2) Click Preferences (or Properties...).

The Print Settings screen of the printer driver appears.

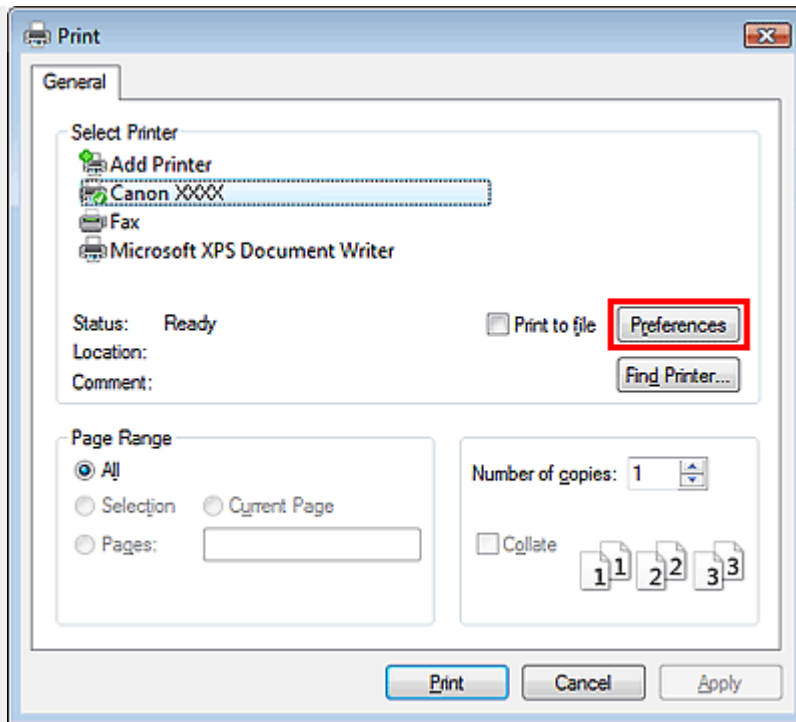

3. Opening the Manual Color Adjustment Dialog Box

- (1) Select the Main tab.
- (2) Set the Media Type and Print Quality.
- (3) Click Manual for Color/Intensity.

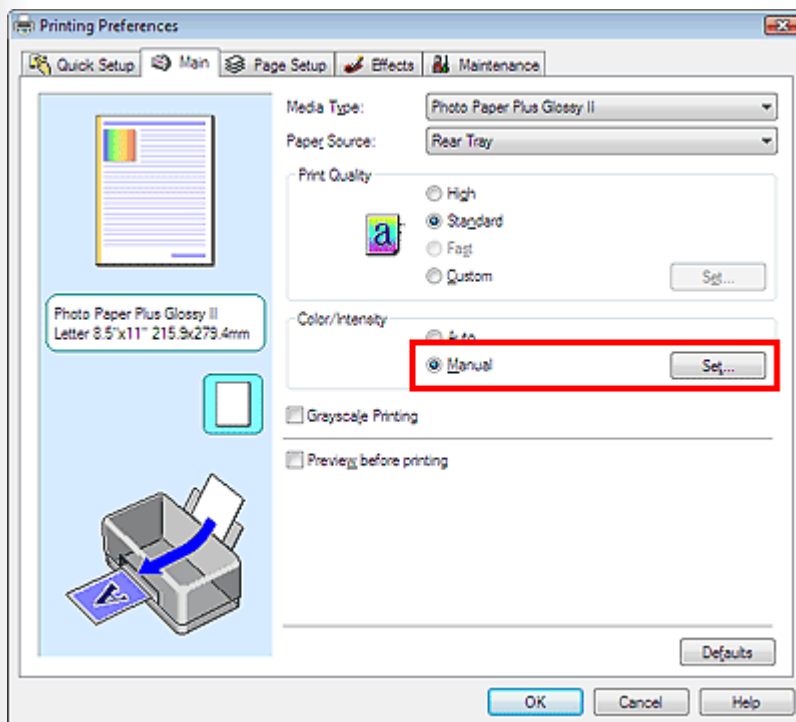

- (4) Click Set... to the right of Manual.
The Manual Color Adjustment dialog box appears.

4. Setting the Color Correction

- (1) Select the Matching tab.
- (2) Select None for Color Correction.

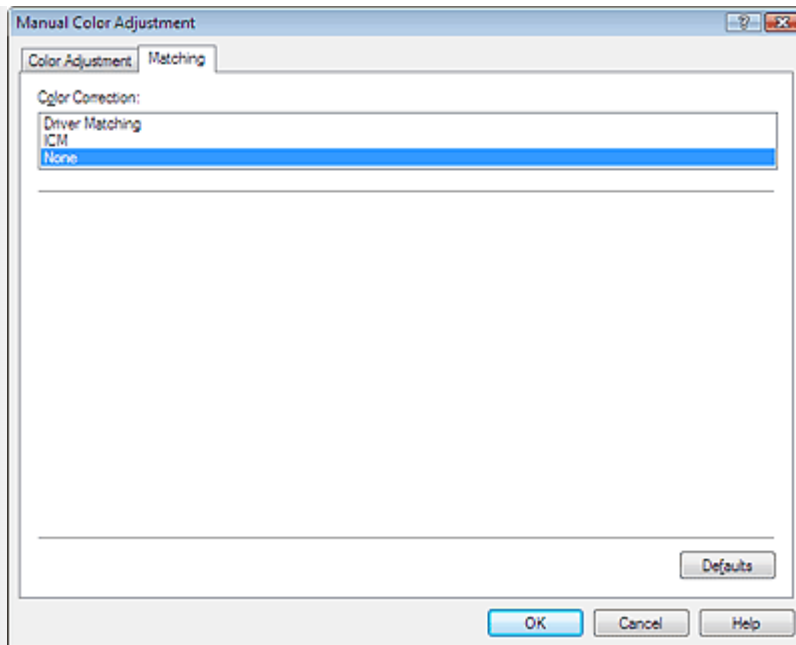

(3) Click OK.

5. Printing

Click Print.

MEMO

- For details on printing procedures and other settings, refer to the On-screen Manual:
Advanced Guide.

[« Previous](#)

[Next »](#)

[Page top ↑](#)

Case 2 Printing by Specifying an ICC Profile within the Application

Print an edited/retouched image by using the ICC profile for printing specified within the application when input ICC profiles can be identified/set in an application other than Easy-PhotoPrint Pro.



Advice

Normally, the ICC profiles required for this printer are installed automatically when a driver is installed. Therefore, you can print using the color space of the source ICC profile (Adobe RGB or sRGB) by following the steps in [Case 1](#).

Follow these steps when using a custom profile or a new downloaded profile for Canon brand paper.

1. Specifying an ICC Profile within an Application

- (1) Open the image you want to print in an application other than Easy-PhotoPrint Pro.

Edit/retouch the image as needed.

- (2) Check that the correct ICC profile has been assigned, select the item that allows the application to manage colors, then specify the profile for printing.

For example, in Adobe Photoshop, select Photoshop Manages Colors, then set a profile as the printer profile.

At this time, please clear the Black Point Compensation checkbox.

memo

- For application settings, see the following section.

[☑Checking the Application Settings](#)

2. Opening the Print Settings Screen of the Printer Driver

- (1) Select the Print command from the application menu.

Example: Click File > Print....

The Print dialog box appears.

- (2) Click Preferences (or Properties...).

The Print Settings screen of the printer driver appears.

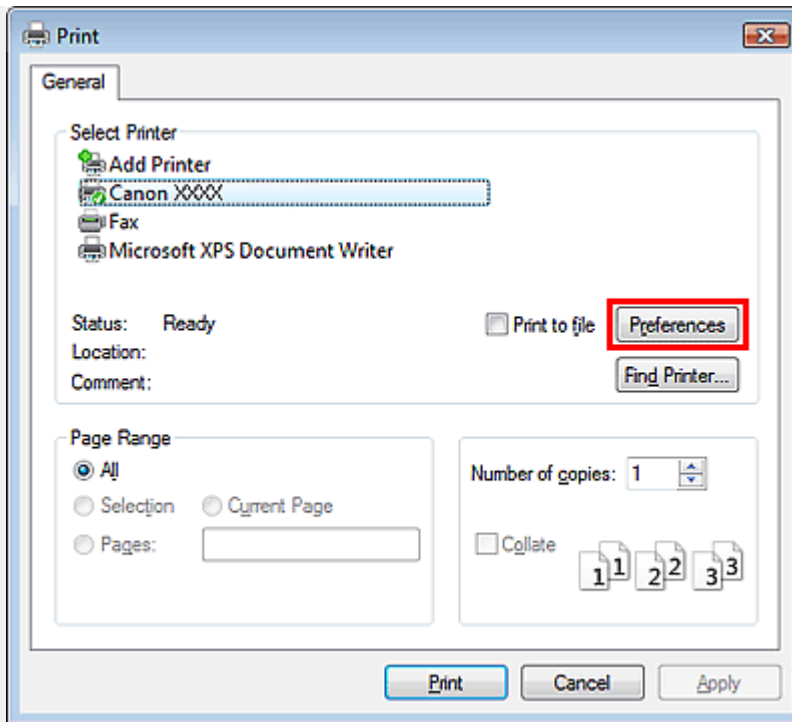

3. Opening the Manual Color Adjustment Dialog Box

- (1) Select the Main tab.
- (2) Set the Media Type and Print Quality.
- (3) Click Manual for Color/Intensity.

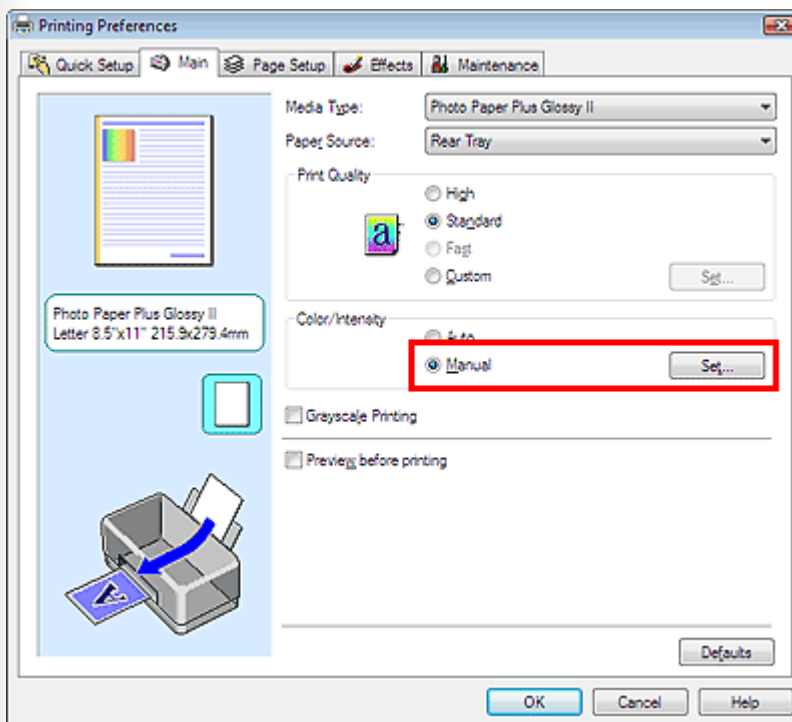

- (4) Click Set... to the right of Manual.
The Manual Color Adjustment dialog box appears.

4. Setting the Color Correction

- (1) Select the Matching tab.
- (2) Select None for Color Correction.

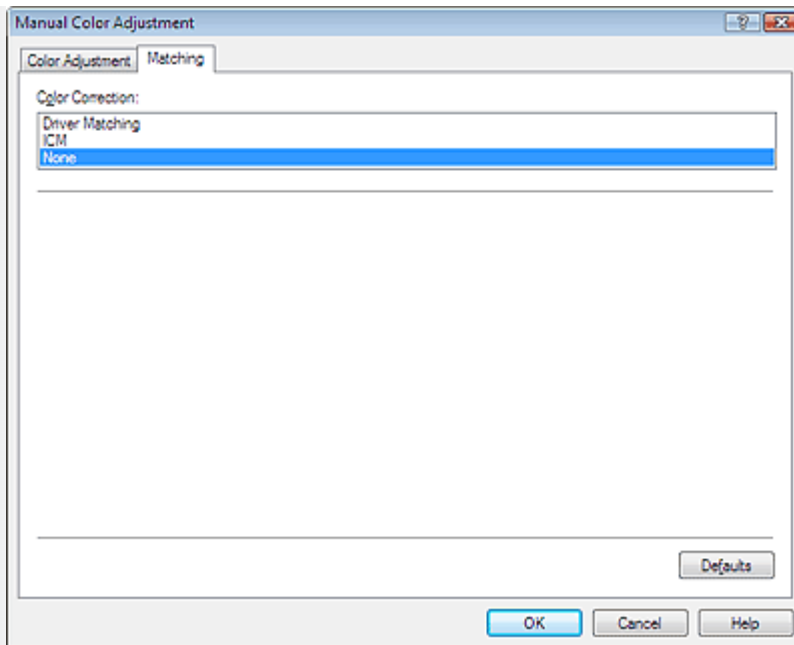

(3) Click OK.

5. Printing

Click Print.

MEMO

- For details on printing procedures and other settings, refer to the On-screen Manual:
Advanced Guide.

[« Previous](#)

[Next »](#)

[Page top ↑](#)

Digital Photo Printing Guide



Digital Photo Printing Guide > Printing from Computers > Printing from Other Applications > Case 3
Printing from Applications in which ICC Profiles Cannot be Set

Case 3 Printing from Applications in which ICC Profiles Cannot be Set

Print an image using the color space of the input ICC profile (Adobe RGB or sRGB) even when you cannot (or do not) identify/set input ICC profiles within an application other than Easy-PhotoPrint Pro.



Advice

Follow these steps to print Adobe RGB images using the Adobe RGB color space from applications that do not support Adobe RGB.

1. Opening an Image in an Application

Open the image you want to print in an application other than Easy-PhotoPrint Pro.

2. Opening the Print Settings Screen of the Printer Driver

(1) Select the Print command from the application menu.

Example: Click File > Print....

The Print dialog box appears.

(2) Click Preferences (or Properties...).

The Print Settings screen of the printer driver appears.

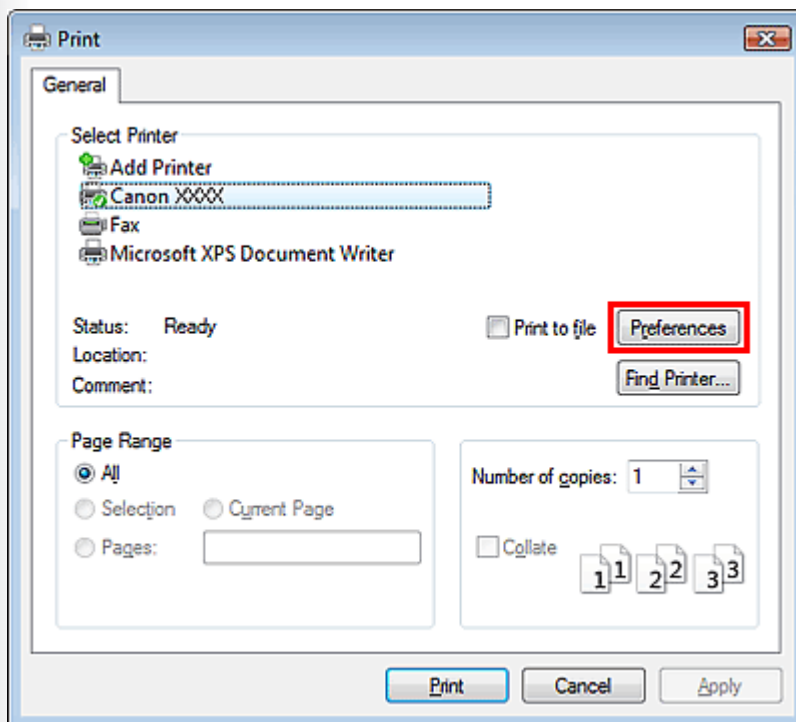

3. Opening the Manual Color Adjustment Dialog Box

(1) Select the Main tab.

(2) Set the Media Type and Print Quality.

(3) Click Manual for Color/Intensity.



(4) Click Set... to the right of Manual.

The Manual Color Adjustment dialog box appears.

4. Setting the Color Correction and Input Profile

(1) Select the Matching tab.

(2) Select ICM for Color Correction.

(3) Set the Input Profile.

For Adobe RGB images, select Adobe RGB (1998).

For sRGB images, select Standard.

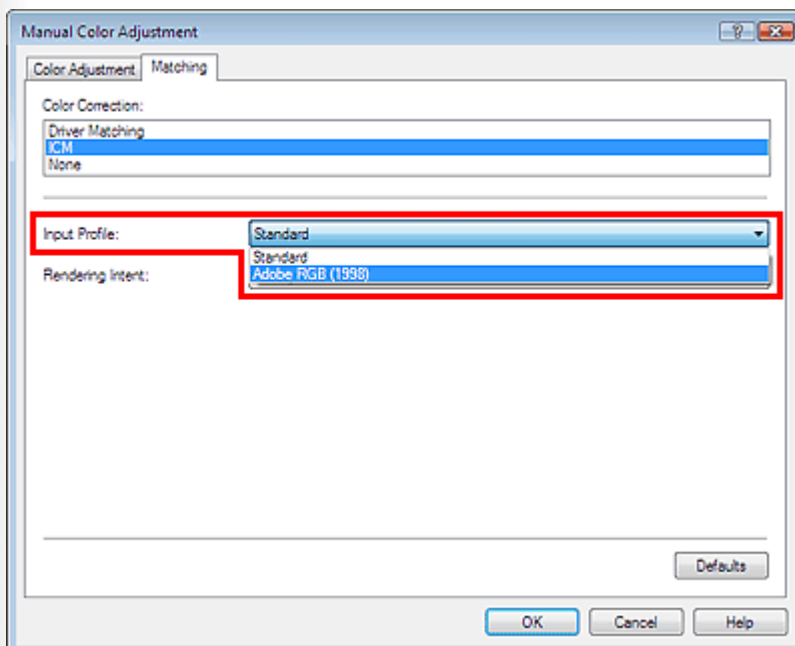

memo

- If an input profile is specified in the application, it takes priority over the input profile specified in the printer driver.

(4) Click OK.

5. Printing

Click Print.

MEMO

- For details on printing procedures and other settings, refer to the On-screen Manual:
Advanced Guide.

 Previous

Next 

Page top 

Digital Photo Printing Guide



Digital Photo Printing Guide > Printing from Computers > Printing from Other Applications > Case 4 Edit/Retouch sRGB Images and Print the Resulting Images

Case 4 Edit/Retouch sRGB Images and Print the Resulting Images

Edit/retouch an sRGB image and print the resulting image.



Advice

Apply Linear Tone to output the subtle color differences between the dark and bright parts without changing the brightness of the darkest (blackest) and brightest (whitest) parts. For example, by applying this effect, you can print a photo of blue sky and shadows without losing the details in the shadowy parts.

1. Opening an Image in an Application

- (1) Open the image you want to print in an application other than Easy-PhotoPrint Pro.

Edit/retouch the image as needed.

- (2) Check that the correct ICC profile (sRGB) has been assigned, then select the item for managing colors using ICC profiles.

For example, in Adobe Photoshop, select Printer Manages Colors for Color Handling.

2. Opening the Print Settings Screen of the Printer Driver

- (1) Select the Print command from the application menu.

Example: Click File > Print....

The Print dialog box appears.

- (2) Click Preferences (or Properties...).

The Print Settings screen of the printer driver appears.

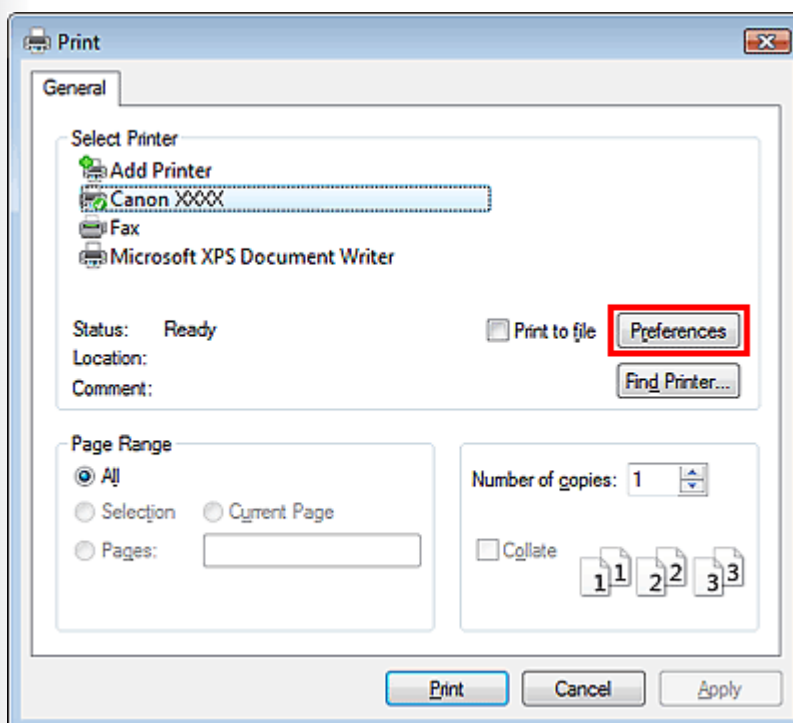

3. Opening the Manual Color Adjustment Dialog Box

- (1) Select the Main tab.
- (2) Set the Media Type and Print Quality.
- (3) Click Manual for Color/Intensity.

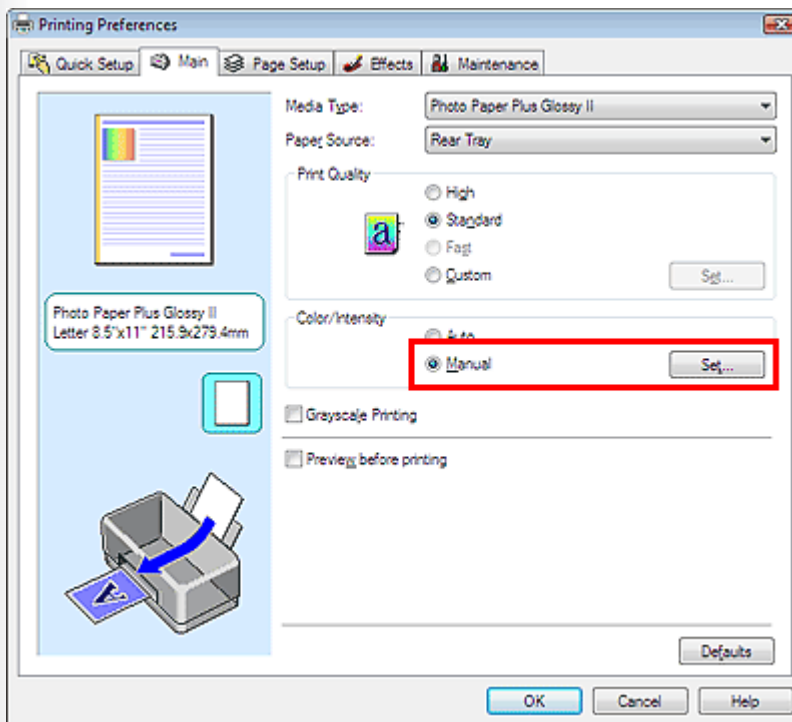

- (4) Click Set... to the right of Manual.
The Manual Color Adjustment dialog box appears.

4. Setting the Color Correction and Color Mode

- (1) Select the Matching tab.
- (2) Select Driver Matching for Color Correction.
- (3) Select Linear Tone for Color Mode.

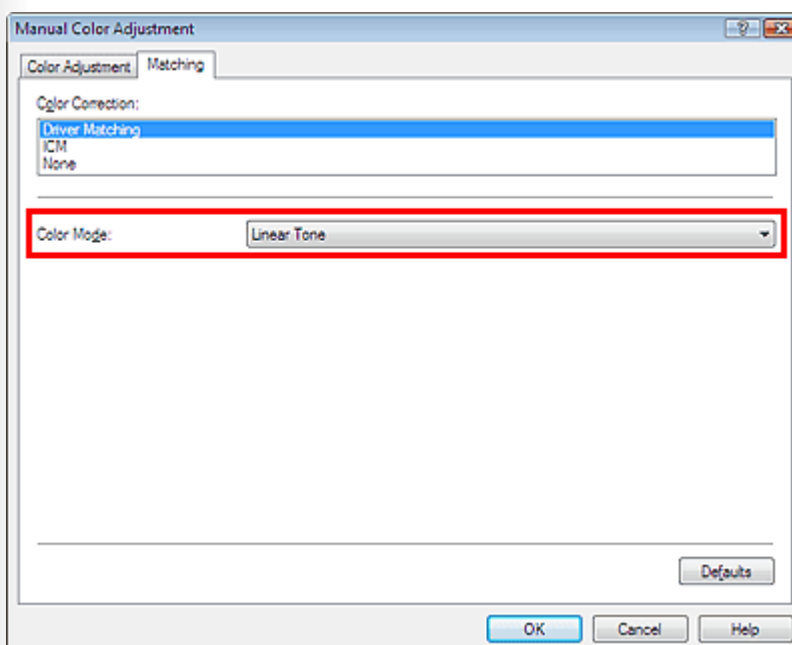

- (4) Click OK.

5. Printing

Click Print.

MEMO

- For details on printing procedures and other settings, refer to the On-screen Manual:
Advanced Guide.

[« Previous](#)

[Next »](#)

[Page top ↑](#)

Digital Photo Printing Guide



Digital Photo Printing Guide > Printing from Computers > Printing from Other Applications > Case 5
Printing with Canon's Unique Color Tones

Case 5 Printing with Canon's Unique Color Tones

Print an sRGB image using Canon Digital Photo Color.



Advice

Canon Digital Photo Color allows you to print images in popular, beautiful color tones. This is achieved by producing high contrast with sharp, three-dimensional feel while reproducing the genuine colors of the original image.

1. Opening an Image in an Application

- (1) Open the image you want to print in an application other than Easy-PhotoPrint Pro.

Edit/retouch the image as needed.

- (2) Check that the correct ICC profile (sRGB) has been assigned, then select the item for managing colors using ICC profiles.

For example, in Adobe Photoshop, select Printer Manages Colors for Color Handling.

2. Opening the Print Settings Screen of the Printer Driver

- (1) Select the Print command from the application menu.

Example: Click File > Print....

The Print dialog box appears.

- (2) Click Preferences (or Properties...).

The Print Settings screen of the printer driver appears.

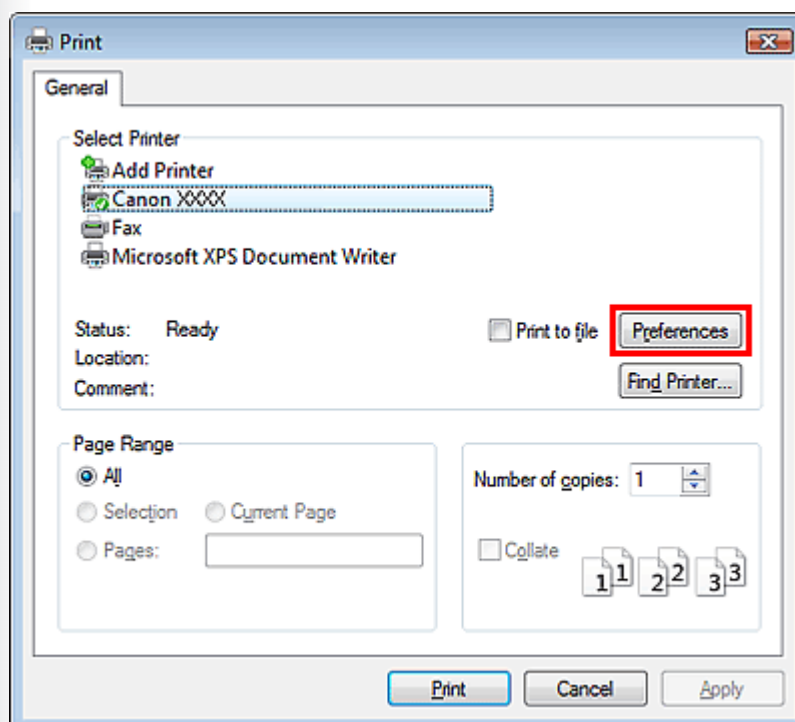

3. Opening the Manual Color Adjustment Dialog Box

- (1) Select the Main tab.
- (2) Set the Media Type and Print Quality.
- (3) Click Manual for Color/Intensity.

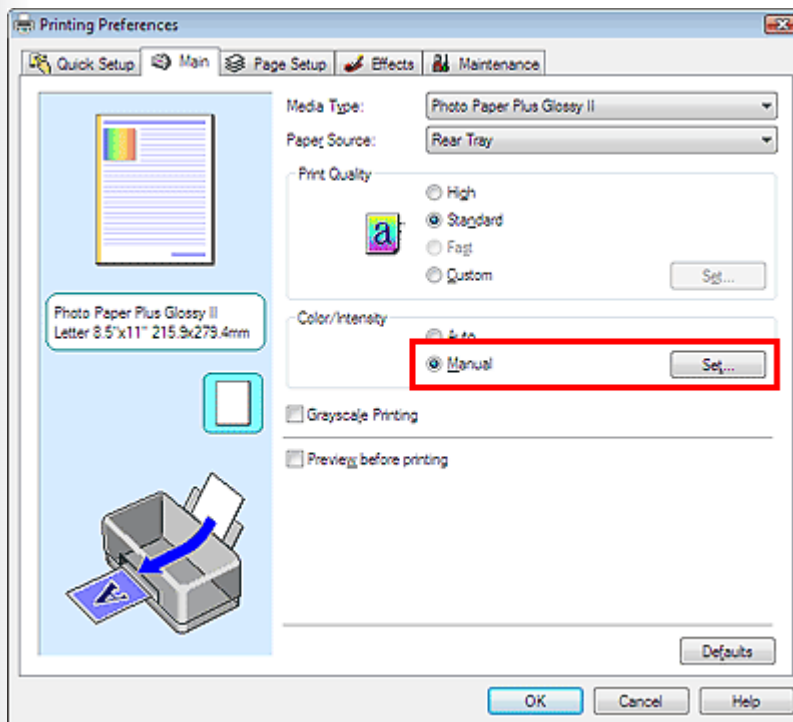

- (4) Click Set... to the right of Manual.
The Manual Color Adjustment dialog box appears.

4. Setting the Color Correction and Color Mode

- (1) Select the Matching tab.
- (2) Select Driver Matching for Color Correction.
- (3) Select Standard for Color Mode.

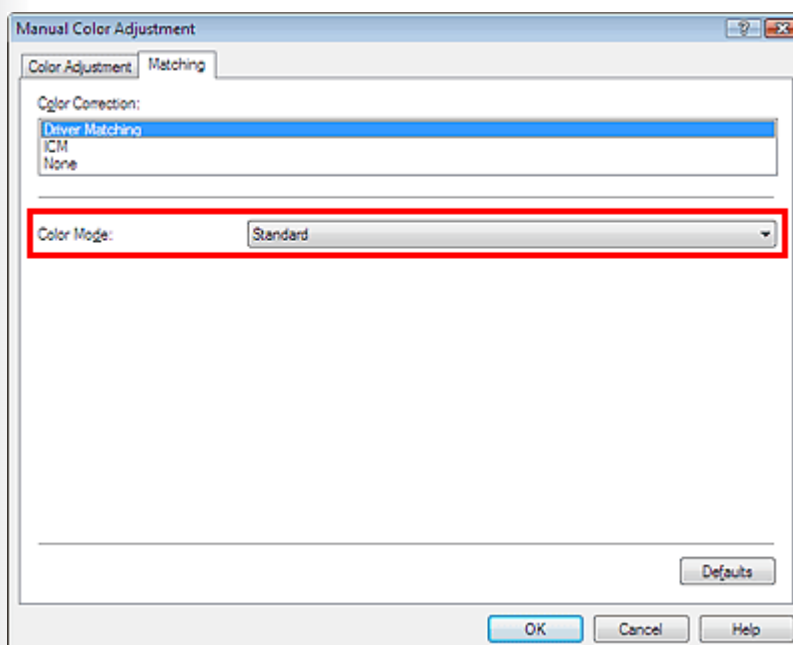

- (4) Click OK.

5. Printing

Click Print.

MEMO

- For details on printing procedures and other settings, refer to the On-screen Manual:
Advanced Guide.

[« Previous](#)

[Page top ↑](#)

Adjusting Colors Flexibly on a Digital Camera before Printing

[Advanced Functions for Direct Printing from Your Camera](#)

[Adjusting Colors before Printing](#)

[Page top](#) 

Digital Photo Printing Guide



[Digital Photo Printing Guide](#) > [Adjusting Colors Flexibly on a Digital Camera before Printing](#) > [Advanced Functions for Direct Printing from Your Camera](#)



Advanced Functions for Direct Printing from Your Camera

This section explains the advanced functions that can be customized on PictBridge-compatible Canon digital cameras.

MEMO

- The following functions can only be customized when a Canon digital camera compatible with the advanced functions is connected to this printer.

Color Mode Setting

In Image Optimize (Print Effect), you can select one of five color modes (Natural, Natural M, Black/White, Cool tone and Warm tone).

For the settings procedure, refer to the manual of your Canon PictBridge-compatible device.

Natural

Images are printed in color tones similar to those of the images captured with a digital camera.

When a setting such as Picture Style is embedded, the effect is reflected in the print results.

Natural M

Change colors when printing images captured with a digital camera by adjusting brightness, contrast, etc.

For items that can be adjusted, refer to the following section.

 [Adjusting Colors before Printing](#)

Black/White

Photos are printed as if they had been taken with black and white film.



Cool tone

Photos are printed in grayscale with a cool bluish tint.



Warm tone

Photos are printed in grayscale with a warm reddish tint.



Next >>

Page top ↑

Digital Photo Printing Guide

[Digital Photo Printing Guide](#) > [Adjusting Colors Flexibly on a Digital Camera before Printing](#) > [Adjusting Colors before Printing](#)



Adjusting Colors before Printing

Select Natural M in Image Optimize (Print Effect) to print in the specified color.

Customizing Brightness and Adjust levels

Select Natural M in Image Optimize (Print Effect) to customize Brightness, Adjust levels, Face brightener and Red-eye corr. before printing.

Brightness

You can adjust the brightness of the entire image by increasing/reducing the midtone luminance, without changing the colors of the darkest (blackest) and brightest (whitest) parts.

Even for a photo of blue sky and shadows, you can make the shadowy parts clearer by brightening.

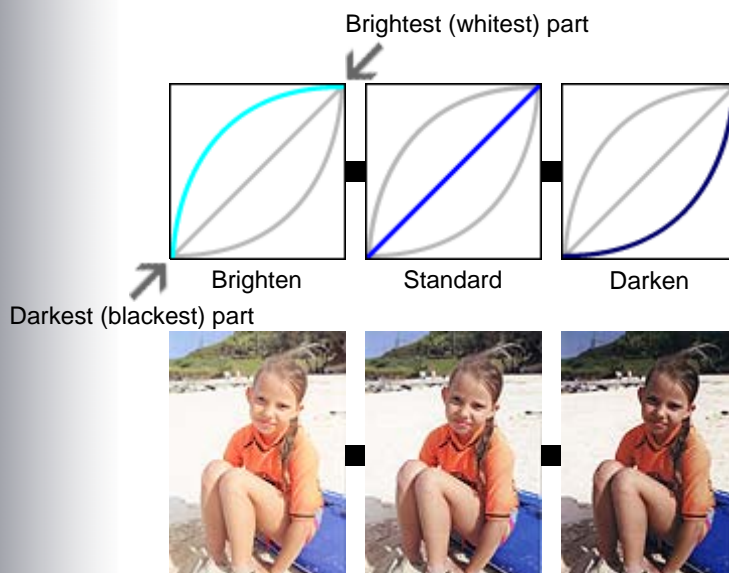

Adjust levels

Specify the darkest (blackest) and brightest (whitest) parts, or detect them automatically to print images most suitable for the midtone luminance.

Exposure can be compensated even if set incorrectly when capturing an image.

Auto

The darkest (blackest) and brightest (whitest) parts of an image are detected and luminance is adjusted to the most appropriate level.

Manual

Specify the darkest (blackest) and brightest (whitest) parts and adjust the luminance to the desired level.

Face brightener

Brightens dark faces caused by bright backgrounds.

Red-eye corr. (Red-eye correction)

Corrects red eyes in images caused by camera flashes.

Customizing Contrast, Saturation, Color tone and Color balance

After selecting Natural M in Image Optimize (Print Effect), you can customize Contrast, Saturation, Color tone and Color balance in Detail set..

Contrast Adjustment

You can adjust the sharpness of the entire image by increasing/reducing the contrast of the midtone luminance, without changing the colors of the darkest (blackest) and brightest (whitest) parts.

You can improve images lacking sharpness by increasing the contrast to turn them into sharp images.

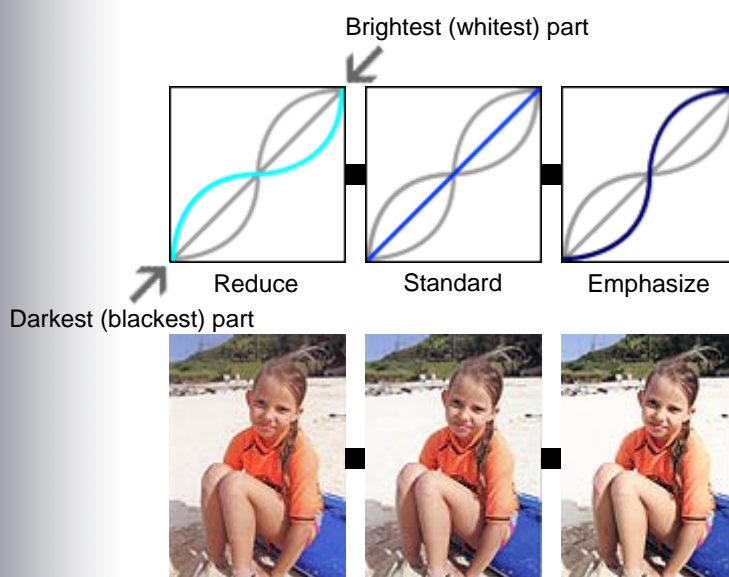

Saturation Adjustment

You can adjust the vividness of the entire image by increasing/reducing saturation, without changing the colors of the darkest (blackest) part, gray axis and brightest (whitest) part.

Emphasize

Makes colors of flowers, etc. more vivid.

Reduce

Reduces redness of skin, etc.

Color Tone Adjustment

You can adjust the color tones of the entire image by rotating the hue, without changing the

colors of the darkest (blackest) part, gray axis and brightest (whitest) part.

+ (+ adjustment)

Makes skin tones yellower.

- (- adjustment)

Makes skin tones redder.

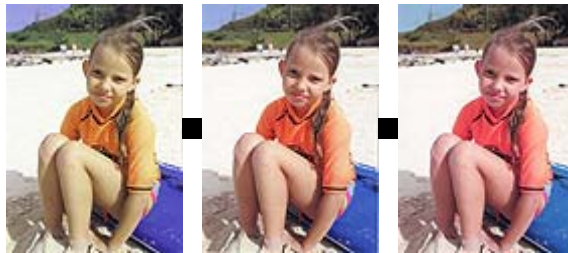

+

Standard

-

Color Balance Adjustment

You can adjust the colors of the entire image by shifting midtone colors, without changing the colors of the darkest (blackest) and brightest (whitest) parts.

You can reduce the blueness of bluish images, such as a shadowy area under blue sky, by adjusting the color to be yellower or redder.

When the colors of captured images are different from human memory colors (pure white of wedding dresses, red of tomatoes, etc.), you can adapt those colors to be closer to memory colors.



G (green) direction



B (blue) direction



Standard



A (amber) direction



M (magenta) direction

Printing in Grayscale

 [Printing Digital Photos in Grayscale](#)

 [Printing Grayscale Photos from Easy-PhotoPrint Pro](#)

 [Printing Grayscale Photos from Other Applications](#)

[Page top](#) 

Digital Photo Printing Guide

Canon

[Digital Photo Printing Guide](#) > [Printing in Grayscale](#) > [Printing Digital Photos in Grayscale](#)



Printing Digital Photos in Grayscale

This printer allows you to print full-color digital photos in grayscale.

For more details, refer to "Printing Grayscale Photos from Easy-PhotoPrint Pro" or "Printing Grayscale Photos from Other Applications".

▣ Printing Rewarding Grayscale Photos

Conventional printers even use color ink to print black and gray for grayscale printing. This has sometimes caused color inconsistency in grayscale photos.

This printer uses black and gray inks for grayscale printing together with the minimum amount of color ink required. This prevents color inconsistency in grayscale photos.

In addition, you can print grayscale photos with a cool bluish tint or a warm reddish tint.



Original full-color image



Photo printed as if it had been taken with black and white film



Grayscale photo with a warm reddish tint



Grayscale photo with a cool bluish tint

Printing Procedures

 [Printing Grayscale Photos from Easy-PhotoPrint Pro](#)

 [Printing Grayscale Photos from Other Applications](#)

[Next](#) 

[Page top](#) 

Digital Photo Printing Guide



[Digital Photo Printing Guide](#) > [Printing in Grayscale](#) > [Printing Grayscale Photos from Easy-PhotoPrint Pro](#)



Printing Grayscale Photos from Easy-PhotoPrint Pro

This section explains how to print digital camera photos in grayscale using Easy-PhotoPrint Pro, an application supplied with this printer, after opening (then editing/retouching) them in Adobe Photoshop CS/Adobe Photoshop CS2/Adobe Photoshop CS3/Adobe Photoshop Elements 6 or Digital Photo Professional.

MEMO

- Easy-PhotoPrint Pro can only be started after installing Easy-PhotoPrint Pro supplied with this printer on a computer on which Adobe Photoshop CS/Adobe Photoshop CS2/Adobe Photoshop CS3/Adobe Photoshop Elements 6 or Digital Photo Professional is installed.

For updated compatibility, visit our website.

>> For details, refer to "Using Easy-PhotoPrint Pro" in the On-screen Manual:

Advanced Guide.

- Using the XPS printer driver enables you to print in the High Dynamic Range (full 16-bit workflow).

>> For details, refer to "Using Easy-PhotoPrint Pro" in the On-screen Manual:

Advanced Guide.

1. Starting Easy-PhotoPrint Pro

- (1) Open the image you want to print in grayscale in an Easy-PhotoPrint Pro-compatible application.
- (2) In Adobe Photoshop, click File > Automate > Easy-PhotoPrint Pro....
Easy-PhotoPrint Pro starts, and the image displayed in Adobe Photoshop appears in Easy-PhotoPrint Pro.



MEMO

- In Digital Photo Professional, click File > Plug-in printing > Print with Easy-PhotoPrint Pro to start Easy-PhotoPrint Pro.

2. Opening the Color Adjustment Dialog Box

- (1) Click Grayscale Photo.
- (2) In the Printer Settings window, click Color Adjustment....

The Color Adjustment dialog box appears.

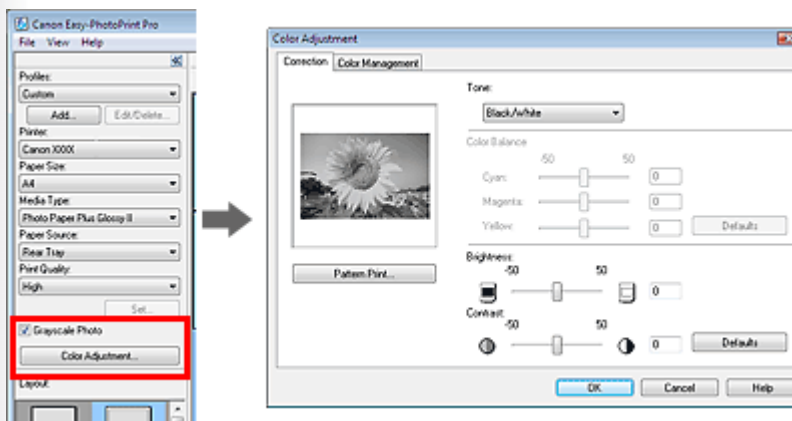

3. Setting Grayscale Photo Color

- (1) Select a grayscale photo color in Tone.

Black/White

Photos are printed as if they had been taken with black and white film.

Cool Tone

Photos are printed in grayscale with a cool bluish tint.

Warm Tone

Photos are printed in grayscale with a warm reddish tint.

Custom

Adjust the Cyan, Magenta and Yellow values in Color Balance to specify the color.

(2) Click OK.

4. Printing

(1) Set the Paper Size, Media Type and Layout.

memo

- White streaks may appear at the top and bottom edges of printed grayscale photos. In that case, print with a 45 mm (1.77 inch) or more margin at the top and bottom edges.

If you select Bordered (Margin 45) for Layout, images will be reduced when printing to allow a 45 mm (1.77 inch) margin at the top and bottom edges relative to the printing direction.

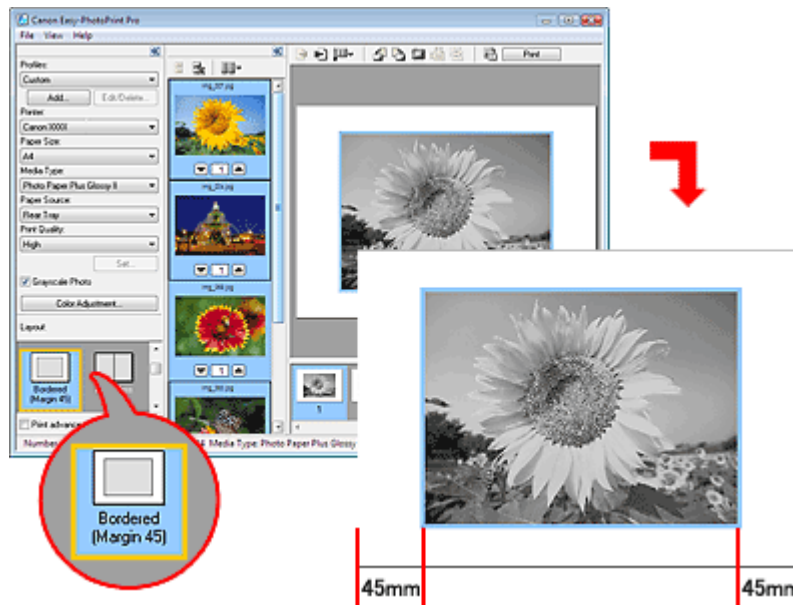

(2) Click Print.

MEMO

- For details on printing procedures and color balance settings, refer to "Using Easy-PhotoPrint Pro" in the On-screen Manual: *Advanced Guide*.

« Previous

Next »

Page top ↑



Printing Grayscale Photos from Other Applications

This section explains how to print grayscale photos from applications other than Easy-PhotoPrint Pro.

MEMO

- Using the XPS printer driver enables you to print in the High Dynamic Range (full 16-bit workflow) from Windows Vista Photo Gallery.
> > For details, refer to "XPS Printer Driver" in the On-screen Manual:
Advanced Guide.

1. Opening an Image in an Application

Open the image you want to print in grayscale in an application other than Easy-PhotoPrint Pro.

memo

- The opened image is converted to grayscale as an sRGB image when printing with "Grayscale Printing" selected.
Convert Adobe RGB images to sRGB images by following the corresponding procedure in your application.

2. Opening the Print Settings Screen of the Printer Driver

- (1) Select the Print command from the application menu.

Example: Click File > Print....

The Print dialog box appears.

- (2) Click Preferences (or Properties...).

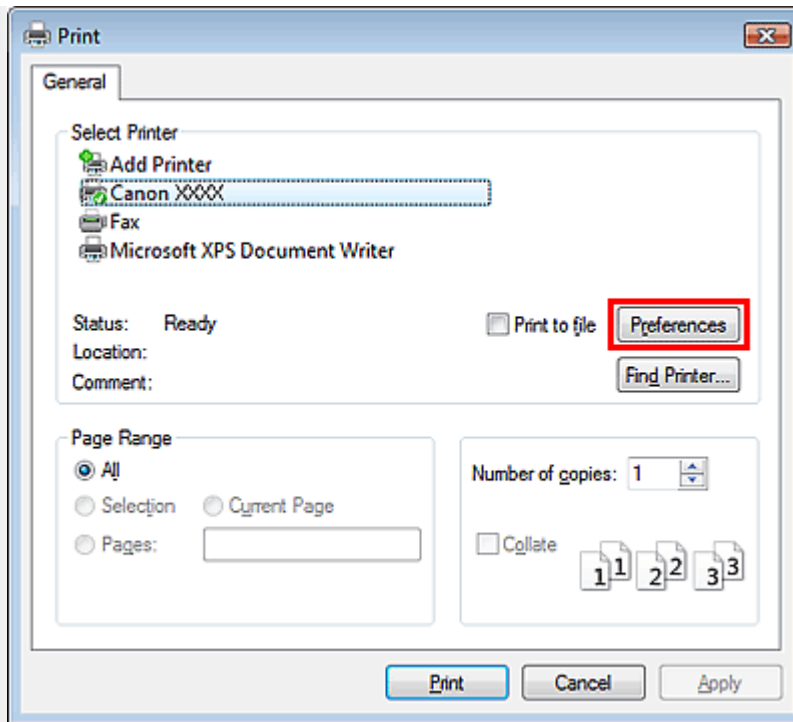

The Print Settings screen of the printer driver appears.

3. Setting Grayscale Printing

- (1) Select the Main tab.
- (2) Set the Media Type and Print Quality.
- (3) Click Grayscale Printing.

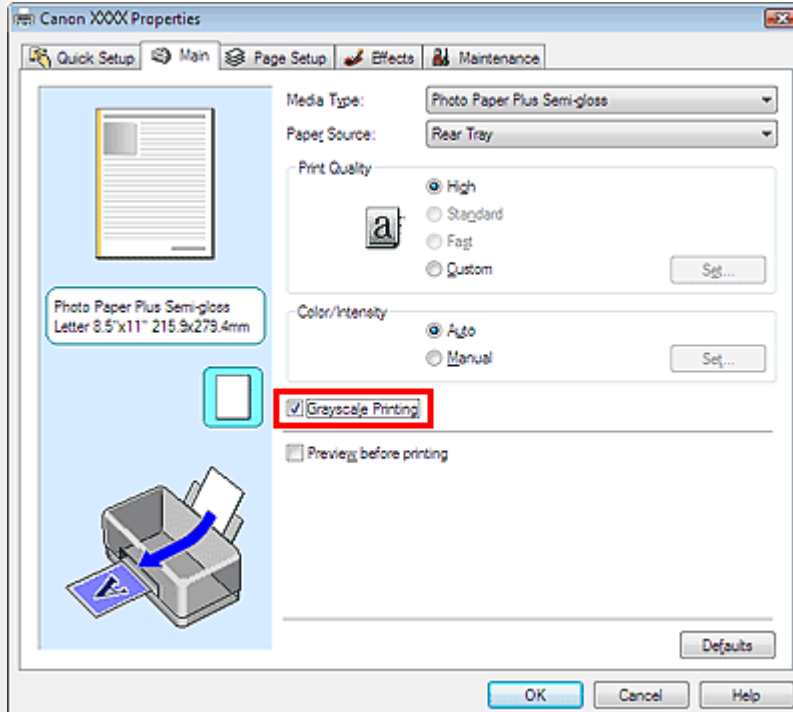

4. Setting the Color Correction

- (1) Click Manual for Color/Intensity.
- (2) Click Set... to the right of Manual.
The Manual Color Adjustment dialog box appears.
- (3) Select a color for grayscale using the Tone slider.
Center

Photos are printed as if they had been taken with black and white film.

Cool side

Photos are printed in grayscale with a cool bluish tint.

Warm side

Photos are printed in grayscale with a warm reddish tint.

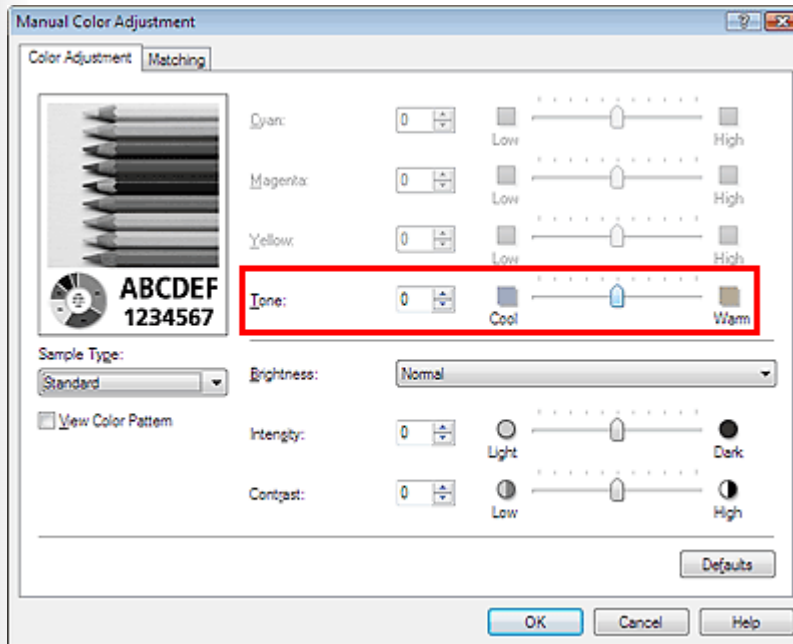

(4) Click OK.

5. Printing

Click Print.

MEMO

- For details on printing procedures and other settings, refer to the On-screen Manual: *Advanced Guide*.
- White streaks may appear at the top and bottom edges of printed grayscale photos. In that case, print with a 45 mm (1.77 inch) or more margin at the top and bottom edges relative to the printing direction.

 Previous

Page top 